

ISBN 978-0-626-26656-1

SANS 208:2012

Edition 1.1

SOUTH AFRICAN NATIONAL STANDARD

The design and installation of compressed natural gas (CNG) vehicle filling stations

Published by SABS Standards Division
1 Dr Lategan Road Groenkloof ☒ Private Bag X191 Pretoria 0001
Tel: +27 12 428 7911 Fax: +27 12 344 1568
www.sabs.co.za
© SABS

SABS



SANS 208:2012
Edition 1.1

Table of changes

Change No.	Date	Scope
Amdt 1	2012	Amended to move reference to national legislation and national departments to the foreword, and to update referenced standards.

Acknowledgement

The SABS Standards Division wishes to acknowledge the valuable assistance derived from publications of the following organization:

The Institution of Gas Engineers (London): *Utilization Procedures*.

Foreword

This South African standard was approved by National Committee SABS TC 1019, *Gas supply, handling and control (fuel, industrial and medical gases)*, in accordance with procedures of the SABS Standards Division, in compliance with annex 3 of the WTO/TBT agreement.

This document was published in March 2012

This document supersedes SANS 208:2005 (edition 1).

A vertical line in the margin shows where the text has been technically modified by amendment No. 1.

Reference is made in 3.3 to the “relevant national authority”. In South Africa, this means the appropriate of the following:

- a) in terms of the Occupational Health and Safety Act, 1993 (Act No. 85 of 1993): the Chief Inspector of the Department of Labour;
- b) in terms of the Mine Health and Safety Act, 1996 (Act No. 29 of 1996): the Mining Engineer;
- c) in terms of the Trade Metrology Act, 1973 (Act No. 77 of 1973): the Director of Metrology;
- d) in terms of the National Water Act, 1998 (Act No. 36 of 1998): the Director-General of Water Affairs and Forestry; and
- e) the local authority concerned. **Amdt 1**

Reference is made in 3.12 to the “relevant national legislation”. In South Africa this means the Engineering Profession Act, 2000 (Act No. 46 of 2000). **Amdt 1**

Reference is made in 3.21 to the “relevant national legislation”. In South Africa this means the Pressure Equipment Regulations as given in the Occupational Health and Safety Act, 1993 (Act No. 85 of 1993). **Amdt 1**

Reference is made in 4.2.2 and 11.3.2.4 to the “relevant national legislation”. In South Africa, this means the Occupational Health and Safety Act, 1993 (Act No. 85 of 1993). **Amdt 1**

Reference is made in 5.1, 5.4.3, 8.1 and 12.1.1 to the “relevant national legislation”. In South Africa, this means the Trade Metrology Act, 1973 (Act No. 77 of 1973). **Amdt 1**

Foreword *(concluded)*

Reference is made in 7.4.2.1 to the “relevant national legislation”. In South Africa, this means the Major Hazard Installation (MHI) Regulations as required by the Occupational Health and Safety Act, 1993 (Act No. 85 of 1993). **Amdt 1**

Annexes A, B, C, D and F form an integral part of this document. Annex E is for information only.

SANS 208:2012
Edition 1.1

This page is intentionally left blank

Contents

	Page
Acknowledgement	
Foreword	
1 Scope	5
2 Normative references	5
3 Definitions	7
4 Legal and allied considerations	9
4.1 General.....	9
4.2 Legal considerations	9
5 General description.....	10
5.1 Gas supply and metering	10
5.2 Gas compressor.....	10
5.3 Gas storage.....	10
5.4 Vehicle filling dispenser.....	10
5.5 Control systems	11
6 General principles of design and installation	11
6.1 General construction (fixed installation).....	11
6.2 Gas quality	11
7 Location and layout of equipment.....	12
7.1 General.....	12
7.2 Hazardous areas.....	14
7.3 Restrictions and isolation distances.....	15
7.4 Enclosures.....	18
7.5 Canopies	19
8 Gas supply and metering to the installation.....	20
9 Gas compressor (including ancillaries).....	20
9.1 General.....	20
9.2 Separators.....	21
9.3 Unloading systems.....	21
9.4 Gas recovery.....	21
9.5 Condensate drainage and disposal	21
9.6 Stage relief	22
9.7 Delivery line non-return valve.....	22
9.8 Gas conditioning	22
9.9 Suction line components.....	22
9.10 Venting	22
9.11 Pipework and fittings	23
9.12 Filters and strainers.....	23
9.13 Instrumentation	23
9.14 Markings.....	24
9.15 Instructions	24

SANS 208:2012

Edition 1.1

Contents (concluded)

	Page
10 Storage facility (including ancillaries).....	24
10.1 Storage cylinders	24
10.2 Pressure relief valves.....	24
11 Valves, shut-down procedures, station pipework and ancillaries	25
11.1 Emergency isolation.....	25
11.2 Routine isolation.....	26
11.3 High-pressure pipework and ancillaries (pipework downstream of the compressor) .	26
11.4 Pressure gauges	27
11.5 Pressure testing	27
11.6 Gas detection system.....	28
12 Vehicle filling dispenser	28
12.1 Dispensing unit.....	28
12.2 Filling hose	28
12.3 Filling nozzle	29
12.4 Dispensing control system	29
13 Electrical equipment and wiring	29
14 Testing, purging and commissioning	30
14.1 General.....	30
14.2 Recommended procedures.....	30
15 Symbolic safety signs	30
16 Prevention and control of fires involving CNG.....	30
16.1 General information.....	30
16.2 Tank installation	31
16.3 Fire extinguishers.....	31
16.4 Leakage of gas.....	31
16.5 Action in emergency.....	31
17 Training	32
Annex A (normative) Gas quality.....	33
Annex B (normative) Instructions for filling.....	35
Annex C (normative) Emergency procedures for mechanical ventilation of enclosures.....	36
Annex D (normative) Hydrostatic and pneumatic testing	37
Annex E (informative) Filling nozzle design	40
Annex F (normative) Purging.....	41
Bibliography	42

The design and installation of compressed natural gas (CNG) vehicle filling stations

1 Scope

1.1 This standard covers the design and installation of compressed natural gas (CNG) vehicle filling stations operating at pressures not exceeding 300 bar.

1.2 This standard applies to filling stations supplied with normally distributed natural gas. It will be appropriate for other fuel gases, including those generated from landfill sites. However, the different constituent characteristics shall be recognized, in particular their possible effect upon materials and operations and their relationship to the vehicles to be operated.

1.3 It relates to filling stations having fast-fill or slow-fill fuel dispensers or both. Where appropriate, they are applicable to self-contained filling units and mobile units.

1.4 This standard does not cover liquefied petroleum gas (LPG). The design and installation of LPG are covered in SANS 10087-3.

1.5 It does not cover filling stations that supply liquefied natural gas (LNG).

1.6 This standard does not cover the installation of underground storage tanks, pumps or dispensers, and pipework at service stations and consumer installations; this is covered in SANS 10089-3.

2 Normative references

The following standards contain provisions which, through reference in this text, constitute provisions of this standard. All standards are subject to revision and, since any reference to a standard is deemed to be a reference to the latest edition of that standard, parties to agreements based on this standard are encouraged to take steps to ensure the use of the most recent editions of the standards indicated below. Information on currently valid national and international standards can be obtained from the SABS Standards Division.

API Spec 5L, *Specification for line pipe*.

ASTM A 269, *Standard specification for seamless and welded austenitic stainless steel tubing for general service*. **Amdt 1**

ASTM D 1142, *Standard test method for water vapor content of gaseous fuels by measurement of dew-point temperature*.

SANS 208:2012

Edition 1.1

- | ASTM D 1945, *Standard test method for analysis of natural gas by gas chromatography.* **Amdt 1**
- BS 6501-1, *Metallic hose assemblies – Guidance on the construction and use of corrugated hose assemblies.*
- EN 10216-2, *Seamless steel tubes for pressure purposes – Technical delivery conditions – Part 2: Non-alloy and alloy steel tubes with specified elevated temperature properties.*
- EN 10217-2, *Welded steel tubes for pressure purposes – Technical delivery conditions – Part 2: Electric welded non-alloy and alloy steel tubes with specified elevated temperature properties.*
- | ~~EN 50073, *Guide for the selection, installation, use and maintenance of apparatus for the detection and measurement of combustible gases or oxygen.*~~ **Amdt 1**
- | EN 60079-29-1, *Explosive atmospheres – Part 29-1: Gas detectors – Performance requirements of detectors for flammable gases (IEC 60079-29-1:2007, modified).* **Amdt 1**
- | EN 60079-29-2, *Explosive atmospheres – Part 29-2: Gas detectors – Selection, installation, use and maintenance of detectors for flammable gases and oxygen (IEC 60079-29-2:2007).* **Amdt 1**
- | ~~EN 61779-1, *Electrical apparatus for the detection and measurement of flammable gases – Part 1: General requirements and test methods.*~~ **Amdt 1**
- PD 5500, *Specification for unfired fusion welded pressure vessels.*
- SANS 1062, *Pressure and vacuum gauges.*
- SANS 1109-1/ISO 7-1, *Pipe threads where pressure-tight joints are made on the threads – Part 1: Dimensions, tolerances and designation.*
- SANS 1109-2/ISO 7-2, *Pipe threads where pressure-tight joints are made on the threads – Part 2: Verification by means of limit gauges.*
- SANS 1123, *Pipe flanges.*
- SANS 1186-1, *Symbolic safety signs – Part 1: Standard signs and general requirements.*
- | ~~SANS 9956-3 / ISO 9956-3 (SABS ISO 9956-3), *Specification and approval of welding procedures for metallic materials – Part 3: Welding procedure tests for the arc welding of steels.*~~ **Amdt 1**
- SANS 10019, *Transportable pressure receptacles for compressed, dissolved and liquefied gases – Basic design, manufacture, use and maintenance.*
- SANS 10086-1, *The installation, inspection and maintenance of equipment used in explosive atmospheres – Part 1: Installations including surface installations on mines.*
- SANS 10087-1, *The handling, storage, distribution and maintenance of liquefied petroleum gas in domestic, commercial, and industrial installations – Part 1: Liquefied petroleum gas installations involving gas storage containers of individual water capacity not exceeding 500 L and a combined water capacity not exceeding 3 000 L per installation.*
- SANS 10087-3, *The handling, storage, distribution and maintenance of liquefied petroleum gas in domestic, commercial, and industrial installations – Part 3: Liquefied petroleum gas installations involving storage vessels of individual water capacity exceeding 500 L.*

SANS 10089-2, *The petroleum industry – Part 2: Electrical and other installations in the distribution and marketing sector.*

SANS 10089-3, *The petroleum industry – Part 3: The installation, modification, and decommissioning of underground storage tanks, pumps/dispensers and pipework at service stations and consumer installations.*

SANS 10108, *The classification of hazardous locations and the selection of apparatus for use in such locations.*

SANS 10142-1, *The wiring of premises – Part 1: Low-voltage installations.*

SANS 10400 (SABS 0400), *The application of the National Building Regulations.*

SANS 11690-3/ISO/TR 11690-3, *Acoustics – Recommended practice for the design of low-noise workplaces containing machinery – Part 3: Sound propagation and noise prediction in workrooms.*

SANS 15614-1/ISO 15614-1, *Specification and qualification of welding procedures for metallic materials – Welding procedure test – Part 1: Arc and gas welding of steels and arc welding of nickel and nickel alloys.*

Amdt 1

3 Definitions

For the purposes of this standard, the following definitions apply:

3.1

acceptable

acceptable to the authority administering this standard, or to the parties concluding the purchase contract, as relevant

3.2

approved

approved by the approving authority

3.3

approving authority

relevant national authority (see foreword)

Amdt 1

3.4

approved inspection authority

AIA

inspecting authority approved or recognized by the approving authority

3.5

canopy

refers to a roof, for example a shelter, a hood, etc., which affords a degree of weather protection

3.6

cascade dispensing sequence

means of allowing efficient use of the gas storage facility using pressure differentials. The total gas storage volume is divided into banks of multiple cylinders, in a volume ratio. Switching takes place between the banks in order to complete the filling process at the desired rate

3.7

competent person

person having the knowledge, training and experience specific to the work or task being performed

SANS 208:2012

Edition 1.1

3.8

design pressure

maximum allowable design pressure which any particular part of a gas fuel system has been designed to withstand

3.9

dew point temperature

temperature, referenced to a specific pressure, at which water vapour or other vapour phase components begin to condense

3.10

dispensing unit

means by which gas is supplied to the vehicle in a controlled and contained manner

3.11

enclosure

building, room or enclosed space that is not substantially open to the outside air and through which there is no free and natural passage of air

NOTE A space that has more than a roof and one solid wall or is surrounded by other buildings or structures in such a way as to obstruct quick dissipation of any released gases or vapours is considered to be enclosed.

3.12

engineering professional

engineer who is registered in terms of the relevant national legislation (see foreword)

Amdt 1

3.13

filling station

location at which hydrocarbon gases are stored and dispensed into a vehicle storage facility

3.14

fire wall

wall, screen or separating partition erected in the open air to reduce the effects from radiated heat and to ensure an adequate dispersion distance for natural gas leaking from a vessel

3.15

gas conditioning equipment

purpose-made equipment to filter or remove (or both) moisture from gas either before or after compression

3.16

hazardous area

three-dimensional region in or at a mine or at works or anywhere where there could be a risk of the ignition of gas, dust, vapour or any other explosive material

3.17

LEL

lower explosive limit

3.18

operating pressure

pressure within systems under normal operating conditions

3.19

pressure water dew point (at container pressure)

water dew point temperature of the gas at the maximum anticipated pressure in the fuel storage container(s) of the CNG vehicular fuel system (usually measured in the fuelling station storage

container(s) before pressure reduction). When presenting or referencing dew point, the value is given in terms of the container pressure, e.g. -20 °C dew point at 24,822 kPa

3.20**recovery vessel**

vessel that recovers gas from the compressor and its ancillaries and which might also serve to damp out pressure pulsations in the compressor inlet

3.21**registered installer**

installer approved and registered in terms of the relevant national legislation (see foreword) **Amdt 1** |

3.22**secondary grade release**

release of gas which is unlikely to occur in normal operation and will only have a limited duration

3.23**separator**

device fitted after each stage of compression, which causes liquids within the gas to drop out of suspension as a liquid for collection

3.24**trim**

integral parts of the compressor, cascades, etc.

3.25**zone 2**

zone in which a flammable gas-air mixture is not likely to occur in normal operation and, if it occurs, will have a limited duration

4 Legal and allied considerations

4.1 General

The legal and allied considerations outlined in this section are particularly relevant to natural gas filling stations in South Africa. Different legal considerations are likely to apply in other countries and reference to the appropriate national legislation will be necessary.

4.2 Legal considerations

4.2.1 Consultation

It will be necessary to obtain planning and building consent from the approving authority.

4.2.2 Legislation

This standard adheres to the requirements of the relevant national legislation (see foreword). Over and above these requirements, a full environmental impact study shall be undertaken before building the filling station. **Amdt 1** |

Requirements for a Major Hazard Installation (MHI) shall be taken into account by the consulting engineer or professional person.

4.2.3 Competency

A person engaged in the design, installation or testing of a gas filling station shall be a competent person to carry out such work. A registered installer shall carry out all installation, testing and maintenance of such filling stations.

5 General description

5.1 Gas supply and metering

Requirements for the incoming gas supply and gas meter installations are dependent primarily upon the pressure and flow demands of the gas compressor. All meters shall be type approved and calibrated. Calibration shall be done at least once a year in accordance with the requirements of the relevant national legislation (see foreword). All meters shall be fitted with pressure and temperature compensation. **Amdt 1**

5.2 Gas compressor

In general, gas compressors for gas filling stations have relatively low flow rates but produce high pressure (typically up to 300 bar). A compressor might supply either bulk storage or a direct filling facility and is usually a multi-stage reciprocating machine, which might be driven by an electric motor or an internal combustion engine.

5.3 Gas storage

A large volume of gas might be stored to facilitate continuous filling of vehicles. Normally, storage is provided in banks of multiple cylinders to speed up filling, to reduce compressor size and to limit the number of start/stop cycles. Usually, cylinders are manifolded together to facilitate a "cascade dispensing sequence" at the filling point.

Cylinders will require revalidation at specified intervals as given in SANS 10019. This might necessitate careful planning in order that the station's delivery rates are not affected significantly during revalidation.

5.4 Vehicle filling dispenser

5.4.1 Components

Generally, a vehicle-filling dispenser comprises:

- a) a dispensing or metering unit;
- b) a filling hose; and
- c) a filling nozzle (appropriate to the maximum allowable pressure of the container being filled).

Gas for dispensing is drawn either directly from a compressor or from on-site storage, then passed into the vehicle. This procedure requires a degree of manual operation similar to liquid filling facilities. For the above dispensing requirements, training shall be given to all staff concerned.

5.4.2 Filling methods

Vehicle filling can be undertaken in two ways:

- a) fast-fill – a filling operation which is comparable in duration to that of liquid fuel; or
- b) slow-fill – a filling operation which takes, typically, several hours, for example overnight.

Normally, slow-fill facilities are unattended during the filling operation, therefore the installation of extra safety and security systems shall be necessary (see 7.4.1).

Equipment used in fast-fill and slow-fill operations differ slightly. However, main system components are similar.

5.4.3 Operation

The dispenser can be in two forms:

- a) a manually or electronically operated dispenser (multi bank); or
- b) a fill post, which is used on slow-fill stations.

On a fast-fill station, the dispenser is used to connect the vehicle to the cascade storage system and control the maximum fill pressure of the vehicle cylinder(s).

On a slow-fill station, the fill post connects the vehicle directly to the compressor discharge line. The vehicle fill pressure in this case is equal to the compressor discharge pressure. A dispensing unit containing a metering device for charging or accounting purposes shall comply with the requirements of the relevant national legislation (see foreword).

Amdt 1

5.5 Control systems

A control system operates the compressor and a storage facility in conjunction with the demands of the vehicle-filling dispenser.

6 General principles of design and installation

6.1 General construction (fixed installation)

6.1.1 All equipment, components, pipework and fittings shall be of a type and manufacture suitable for their intended use, including for the full range of pressures, temperatures and loadings which might occur under normal and fault conditions. They shall also be installed and used in accordance with the manufacturer's instructions.

6.1.2 A compressor, storage facility or vehicle-filling dispenser shall be installed on a firm, flat, horizontal bed or platform.

6.1.3 For emergency and recovery of vehicles, mobile filling stations may be used.

6.1.4 All cylinder banks shall be above ground.

6.2 Gas quality

6.2.1 Gas supplied to the filling station

6.2.1.1 Gas quality in the onboard vehicle storage container shall comply with the following:

H ₂ S and soluble sulfide partial pressure	344 Pa, max.
Water vapour	8,9 mg/L, max.
CO ₂ partial pressure.....	48,26 kPa, max.
O ₂	0,5 volume %, max.

SANS 208:2012

Edition 1.1

Natural gas introduced into a system covered by this standard shall have a distinctive odour potent enough for its presence to be detected down to a concentration in air of not over 1/5 of the lower limit of flammability (explosion limit). See A.2 for information on the concentration in air.

For additional information on gas quality see annex A.

6.2.1.2 The methane content should be given consideration due to periodic fluctuations in supply composition from the gas transmission system and advice should be sought from the gas reticulation company.

6.2.2 Gas supplied from the compressor

6.2.2.1 Gas passing from the compressor or its associated downstream drier, if fitted, shall have a moisture content which will not cause hydrate or water formation in any downstream equipment or vehicle fuel system, under the expected operating conditions.

In order to achieve the required moisture content, it may be necessary to install a gas drying system, which may in turn reduce the odorant level of natural gas. Gas supplied from a drying system used shall comply with the gas quality in terms of odorant level as specified in annex A.

6.2.2.2 Particulate concentration shall be minimized to avoid contamination, clogging and erosion of fuel system components. The fuel shall be processed with a filter rated at 5 µm nominal (i.e. 96 % efficiency) particle size. CNG fuel delivered to the vehicle shall have particulate matter content equal to or less than 5 µm in size.

6.2.2.3 Lubricating oils are often present in natural gas at trace levels due to carryover from pipeline compressors or on-site fuelling station compressors. Excessively high levels of lubricating oil entrained or absorbed in natural gas can condense and might create vehicle operational problems (for example, liquids in the fuel pressure regulator). Additional gates are required to determine acceptable lubricating-oil levels as well as standardized test procedures for quantifying lubricating oil content. However, it shall be understood that levels adversely affecting compressed natural gas vehicle (CNGV) performance are not permitted. Lubricated compressor oil levels should be monitored and coalescing filters may be installed downstream of the compressor discharge to control oil.

6.2.3 Maintenance and servicing

Maintenance or servicing anticipated during operation of the filling station shall not affect the quality of gas supplied from the station.

7 Location and layout of equipment

7.1 General

7.1.1 The filling station should be located outdoors. However, certain items of equipment may be enclosed, but only in accordance with this standard.

7.1.2 Site location and layout shall be planned carefully as most of the site components have location restrictions and minimum isolation distances and might be affected by "hazardous area" requirements.

Figure 1 is a diagrammatic representation of applicable restrictions and isolation distances.

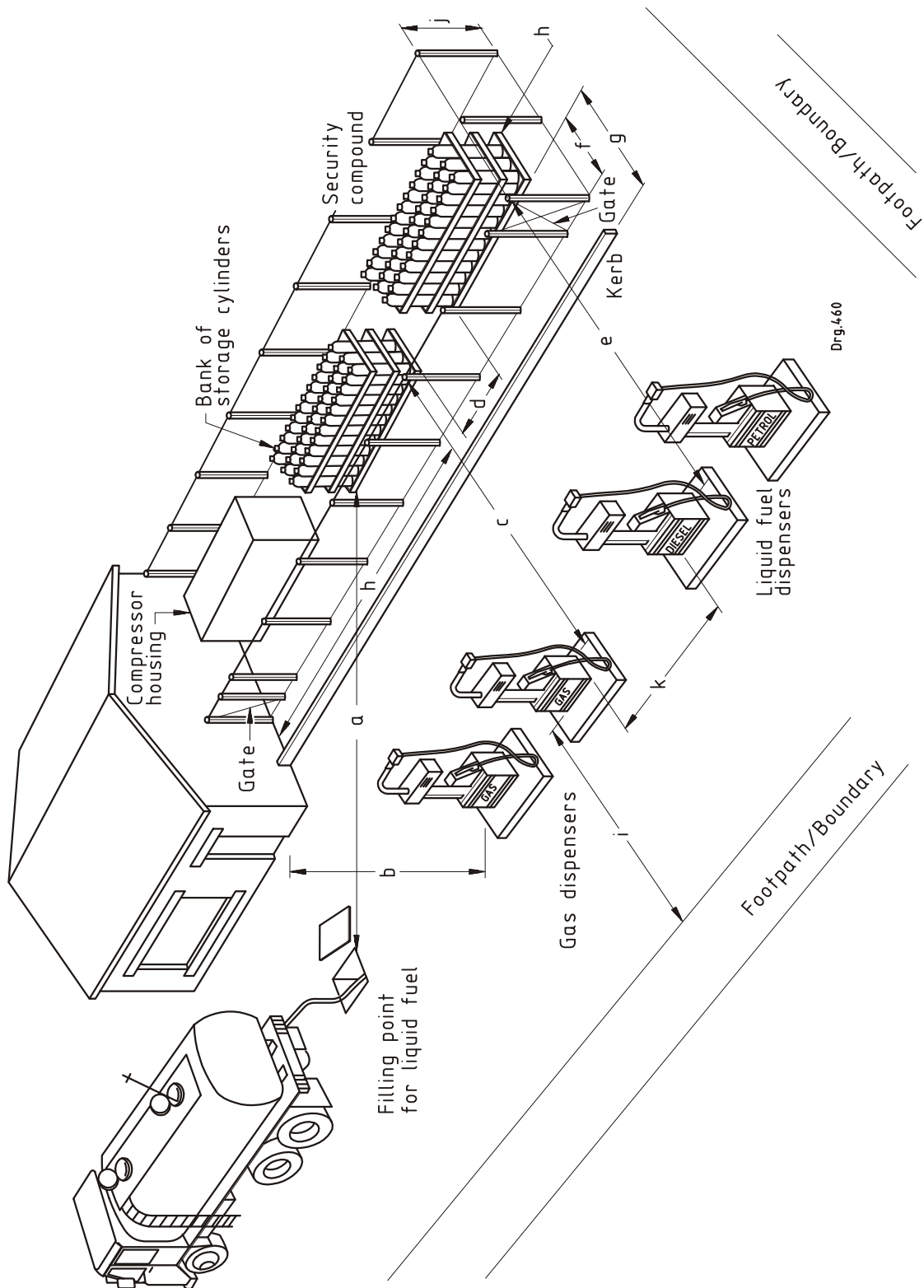

Figure 1 — Restrictions and safety distances

Key

- a Distance between the liquid storage facility, liquid filling point or liquid dispensing point and the bank of storage cylinders
- b Distance between vehicle filling dispenser and an opening into a building
- c Distance between vehicle filling dispenser and bank of storage cylinders
- d Distance between the two bank of storage cylinders
- e Distance between the liquid storage facility, liquid filling point or liquid dispensing point and the bank of storage cylinders
- f Distance between the fence and the bank of storage cylinders
- g Distance between the kerb or barrier and the bank of storage cylinders
- h Minimum safety distance of a storage facility from buildings, site boundary or fixed ignition source
- l Distance from the vehicle filling dispenser to the footpath or site boundary
- j Height of the fence
- k Distance between the fuel dispenser and the gas dispenser

1	2	3
Description of distances	Minimum safety distance m	Appropriate subclause
a	5	7.3.2.6
b	4	7.3.3.3(c)
c	2	7.3.3.3(b)
d	1	7.3.2.5
e	5	7.3.2.6
f	1	7.3.2.7
g	2	7.3.2.9
h	Dependent on storage volume	Table 1
i	4	7.3.3.3(a)
j	2	7.3.2.7
k	Dependent on type of equipment	7.3.3.6
NOTE Additional safety distances may be imposed by hazardous area classifications (see 7.2).		

Figure 1 — Restrictions and safety distances (concluded)

7.2 Hazardous areas

7.2.1 Hazardous areas shall be approximated at an early stage in a project to allow electrical equipment to be specified and other potential sources of ignition to be located. However, a definitive drawing shall be produced before operation of the filling station and shall be based on SANS 10400 or an approved standard.

7.2.2 A hazardous area classification analysis shall be undertaken for the location of electrical and other sources of ignition. The classification of hazardous areas shall be in accordance with SANS 10108.

7.2.3 A flammable air-gas mixture is not likely to occur in normal operation of a CNGV filling station. Therefore, a hazardous area classification of Zone 2 normally shall be applied, except for the dispenser unit which shall be classed as Zone 1, as defined in SANS 10108.

Zoning can be applied to secondary grade releases in the following situations:

- a) within interiors of dedicated buildings, housings and enclosures with purpose-designed ventilation of a rate to ensure that a potential gas release (see 7.4.2) is unlikely to reach a concentration of 25 % LEL anywhere except in the vicinity of the release; and
- b) outdoors.

Secondary grade releases might occur at flange joints, compression fittings, screwed pipe joints, valve glands, regulator diaphragms, etc.

A building or enclosure not containing a source of release, but falling within a hazardous zone, normally shall assume the same classification as that zone unless there are no openings into the hazardous area and the structure can be shown to be impervious to the likely penetration of a flammable gas atmosphere.

7.3 Restrictions and isolation distances (see figure 1)

7.3.1 Compressor (including ancillary equipment)

7.3.1.1 A hazardous area classification shall be applied (see 7.2).

7.3.1.2 Installation shall be in a well-ventilated location, ideally in the open air (see 7.4.2).

7.3.1.3 Access shall be available for maintenance. Clearance should be provided on all sides and above the compressor in accordance with the manufacturer’s instructions.

7.3.2 Above ground storage facility (including ancillary equipment)

7.3.2.1 A hazardous area classification shall be applied (see 7.2).

7.3.2.2 Installation shall be in a well-ventilated location, ideally in the open air (see 7.4.2). The base of the facility shall be designed to prevent the collection of liquids, for example water, liquid fuels etc., beneath the storage cylinders (see also figure 2).

7.3.2.3 The facility shall be at least the minimum isolation distance shown in table 1 from a building (excluding from a purpose-designed compressor housing, see 7.4), the site boundary or a fixed ignition source.

Table 1 — Minimum safety distance of a storage facility from buildings, site boundary or fixed ignition source

1	2	3
Storage volume (water capacity) L	Minimum safety distance	
	Without fire wall m	With fire wall m
Not exceeding 10 000	4,0	1,0
Exceeding 10 000	10,0	4,0

SANS 208:2012

Edition 1.1

7.3.2.4 If a fire wall is constructed, thus reducing the minimum isolation distance, it shall be of at least 2 h fire-resisting construction, imperforate and of solid masonry or concrete. The wall shall be at least as high as the highest cylinder bank and have a minimum height of 2 m. It shall be long enough to ensure that the minimum distance given in table 1 is attained when measured from the nearest cylinder in the bank around the wall.

The fire wall shall be at least 1 m away from a storage cylinder. If a reduction in the extent of the hazardous area zone is required, it may be necessary to amend the dimensions of the fire wall.

7.3.2.5 Each bank of cylinders shall be separated by at least 1 m.

7.3.2.6 The facility shall be at least 5 m from a liquid fuel storage facility, liquid filling point or liquid dispensing point.

7.3.2.7 If the facility is to be located in the open air, a fence placed at least 1 m from a cylinder shall enclose it.

Such a fence shall be at least 2 m high. It shall prevent physical damage of equipment as well as unauthorized access.

7.3.2.8 The storage facility shall not be installed underneath high voltage cables.

7.3.2.9 Vehicles shall be prevented physically from approaching the facility to within a distance of 2 m, for example by the construction of a raised kerb, barrier, etc.

7.3.2.10 Cylinders shall be contained within a bank and shall be fixed in one of the following manners:

a) by strapping within a pack; or

b) within a pallet.

7.3.2.11 A vertical cylinder bank should be limited in size to 1,5 m wide × 5,5 m long × one cylinder height high (to a maximum height of 2 m).

7.3.2.12 A horizontal cylinder bank should be limited in size to 5,5 m wide × 2,0 m high × one cylinder length long.

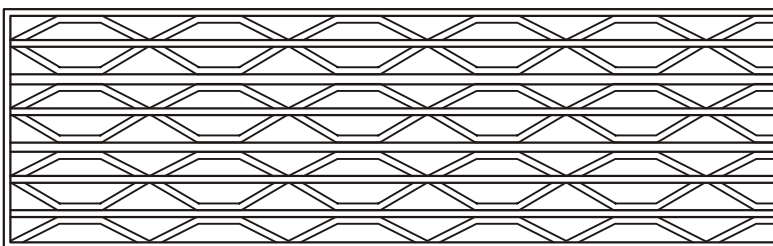

Drg.4.60a

Dimensions of I.G.D standard panel: 1 270 mm × 685 mm × 18 mm

a) Panel pattern

Figure 2 — Grating stand for panels for storage banks

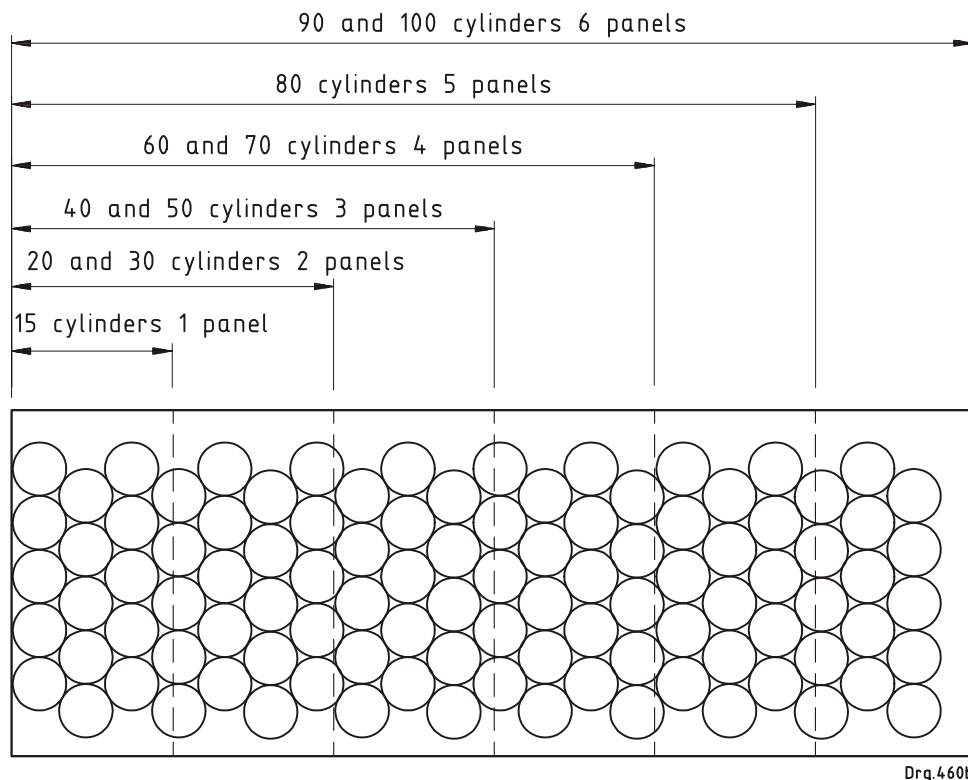

b) Diagram illustrating number of panels to bank size

Figure 2 — Grating stand for panels for storage banks (concluded)

7.3.3 Vehicle filling dispenser

7.3.3.1 A hazardous area shall be classified in accordance with SANS 10108 (see 7.2). However, it is accepted that vehicles, which are to be fuelled, may enter the hazardous zone around the dispenser, subject to the adoption of safe filling procedures. Such procedures are given in annex B.

7.3.3.2 Location should be in the open air and in a well ventilated position.

7.3.3.3 Dispensers shall be located at the following minimum distances:

- 4 m from the site boundary;
- 2 m from a storage facility; and
- 4 m from an opening into a building.

7.3.3.4 Dispensers shall be positioned so that vehicles have adequate space to manoeuvre into and out of the filling position. In addition, dispensers shall be protected from vehicular damage.

7.3.3.5 Where a slow-fill facility is provided, adequate protection should be provided against unauthorized interference, particularly during periods of unmanned filling operations.

7.3.3.6 Where a liquid fuel dispenser is to be located in the vicinity of a gas dispenser, reference shall be made to the classification of electrical equipment in hazardous areas (see also SANS 10089-2).

7.4 Enclosures

7.4.1 General

7.4.1.1 A compressor or storage facility should be installed in the open air. However, where this might result in unacceptable aspects, for example of safety, security, noise levels, weather exposure, etc., consideration should be given to the use of an enclosure, with a designed ventilation system (see 7.4.2).

7.4.1.2 A compressor and storage facility, including their respective ancillaries, shall not be housed in the same enclosure unless they are located within independent compartments, which are ventilated separately in accordance with 7.4.2.

7.4.1.3 An enclosure used to house a compressor or a storage facility (or both), including their respective ancillaries, shall not be used for any other purpose.

7.4.1.4 An enclosure shall incorporate means for explosion relief, sufficient to ensure structural integrity in the event of an explosion within it.

7.4.2 Ventilation

7.4.2.1 A "potential gas release" shall be quantified in accordance with the relevant national legislation (see foreword). **Amdt 1**

7.4.2.2 A ventilation system shall be provided which, under normal operating conditions:

- a) ensures continuous dilution of the ambient air such that a potential gas release will not produce a concentration of flammable gas of greater than 25 % LEL;
- b) ensures that there are no "dead" spaces where a leaked flammable gas could accumulate; and
- c) provides sufficient ventilation to cater for air-cooling requirements of the enclosed equipment.

7.4.2.3 Ventilation air shall be uncontaminated and be taken from a non-hazardous area. Ventilation inlets shall be sited such that a flammable atmosphere cannot be induced into the ventilation system.

7.4.2.4 A ventilation opening shall not be liable to obstruction.

7.4.2.5 Acoustic treatment shall not reduce the effectiveness of ventilation openings.

7.4.2.6 A mechanical ventilation shall be considered liable to failure and the protective measures prescribed in 7.4.3 shall be applied.

7.4.2.7 An enclosure which houses a storage facility, including its ancillaries, shall have a fully natural ventilation system. Elements of mechanical ventilation shall not be used.

7.4.2.8 An enclosure which houses a compressor, including its ancillaries, may have a combination to any degree of natural and mechanical ventilation.

An example of a combined ventilation type would be sufficient natural ventilation to accommodate a "potential gas release" at the maximum compressor inlet pressure with additional mechanical ventilation to accommodate a "potential gas release" at the maximum compressor outlet pressure.

7.4.3 Protection against failure of mechanical ventilation (see also annex C)

The ventilation system design shall include an emergency procedure, which ensures that, upon failure of the ventilation system, it shall:

- a) protect a subsequent leakage of gas from ignition sources; and
- b) prevent a potential gas release (see 7.4.2) from accumulating to form a flammable atmosphere.

7.5 Canopies

A canopy shall not inhibit natural ventilation and shall be designed to prevent the accumulation of a potential gas release (see 7.4.2). A typical example of a canopy is given in figure 3. The section below the canopy to the filling station floor shall be classed as Zone 2, however, the area around the dispensing unit shall be classed as Zone 1 (see figure 3).

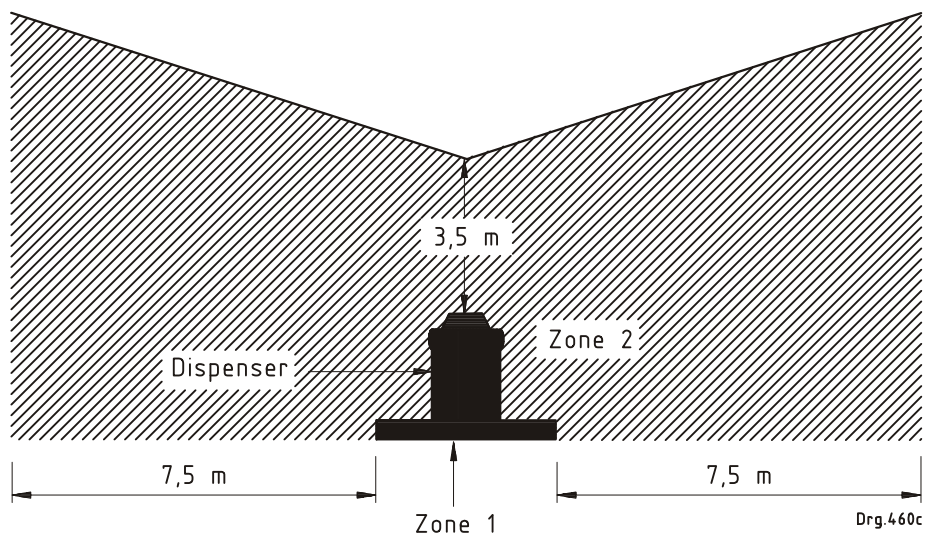

a) Front view of the canopy

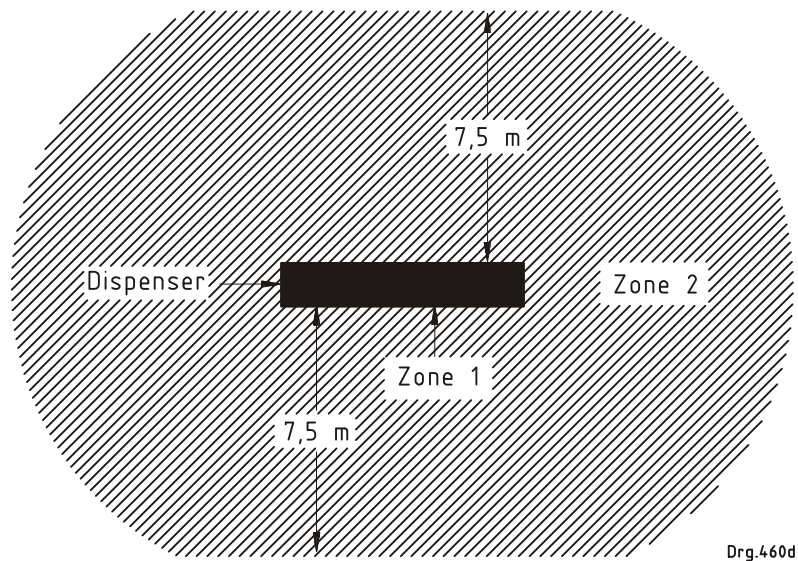

b) Top view of the canopy

Figure 3 — Classified areas in and around the CNG canopy

8 Gas supply and metering to the installation

8.1 A filling station shall have approved meters where relevant for the gas supply which supplies gas to the gas compressor(s), in order to satisfy the requirements of the relevant national legislation (see foreword). **Amdt 1**

8.2 Consideration shall be given to the effects of the operation of a compressor on the local gas supply network. The gas distribution company shall be advised of the existence of the installation in order that the anticipated transient flow variations can be checked for compatibility with the overall gas supply or metering system for the site.

8.3 Where flexible connections are to be used in the installation, they shall be stainless steel flexible pipes that comply with the requirements of BS 6501-1.

8.4 A non-return device shall be fitted immediately downstream of the meter and be of a type acceptable to the gas transportation company. In a low pressure inlet installation, it is unlikely that a non-return valve will be available that has a sufficiently low pressure drop, sufficient damping against oscillation and that will take a high reverse pressure of the level which might occur. Therefore, a manual reset slam-shut valve shall be located on the meter outlet together with a protecting relief valve, both of which shall be installed and maintained by the customer to the standards and procedures required by the gas transportation company. The slam-shut valve shall be mounted in the reverse direction in order to protect the supply system against a high reverse pressure. The relief valve shall be set to vent before the slam-shut valve operates to avoid continual nuisance shut down of the valve.

Consideration shall be given to remote indication in the event of the relief valve operating continuously.

The shut-off valve will afford protection of the gas transportation system and of the gas meter against a sudden high reverse pressure, which might occur under a fault condition. However, such a reverse pressure is unlikely to occur where a compressor relief control is vented to atmosphere.

8.5 A low gas pressure switch shall be located such as to sense the event of the inlet gas pressure to the compressor falling below an acceptable level. On failure of the inlet gas pressure, the compressor shall be shut down and not be permitted to re-start automatically. Such a switch should be acceptable to the gas transportation company.

8.6 The system shall be designed such that a filter element can be changed safely and easily. In addition, purge points and very small bore re-pressurizing valves should be fitted.

It might be necessary to provide gas-conditioning equipment to reduce the water vapour content in the gas, before compression (see 6.2.2.1). If so, the compressor manufacturer shall be consulted with regard to the specification of such equipment.

9 Gas compressor (including ancillaries)

9.1 General

9.1.1 A compressor shall be designed for safe operation and shall be capable of continuous full load duty.

9.1.2 A compressor shall be provided with adequate means of support or mounting to minimize the transmission of noise and vibration to the structure.

A reciprocating compressor may be mounted on a solid mass concrete bed and fixed rigidly thereto or on anti-vibration mountings (AVMs). Where AVMs are used, generally it will be necessary to ensure that all service connections are flexible. Many compressors are designed specially for AVMs and it is often not possible to fit AVMs to compressors designed for rigid mounting without having to make considerable adaptation.

9.1.3 A compressor intended for outdoor installation shall have all controls and electrical equipment protected adequately to ensure safe and reliable operation. The control panel shall be remote from the compressor.

9.1.4 Materials and finishes, including any trim and lubricants used in the construction, shall be suitable for the conditions of use as designated by the compressor manufacturer.

9.1.5 Components, integral parts and user controls that may require adjustment or replacement during servicing, operation and maintenance shall be easily accessible.

9.1.6 A compressor shall be treated acoustically to comply with the requirements of SANS 11690-3.

9.2 Separators

A separator shall be fitted downstream of a final cooler to collect oil, water or condensate from the gas. Interstage separators may also be fitted at the discretion of the compressor manufacturer.

9.3 Unloading systems

9.3.1 A compressor shall be fitted with an unloading system to minimize the loading during the starting period. Unloaded gas shall be returned to the suction side of the compressor in such a manner that the suction side is not over-pressurized.

9.3.2 A non-return valve shall be fitted in the gas supply line upstream of the unloaded gas return point.

9.4 Gas recovery

9.4.1 A gas recovery vessel, designed and manufactured in accordance with PD 5500, shall be fitted to collect any gas released from a separator, unloading system or condensate collector, during compressor operation.

9.4.2 The recovery vessel shall be fitted with an emergency relief valve, vented to atmosphere at a safe discharge point.

9.5 Condensate drainage and disposal

9.5.1 A safe and controlled system shall be used to facilitate liquid removal from the point of condensate collection. The system shall be located in the open air, protected from freezing.

9.5.2 Liquid condensate shall not be disposed of in a public sewer, storm drain or drain not designed to contain flammable liquids.

9.5.3 Condensate from the separator and the unloading system shall be collected for disposal.

9.6 Stage relief

9.6.1 Each stage of compression shall be fitted with a rated spring-loaded relief valve, vented to atmosphere at a safe discharge point.

9.6.2 The set pressure of each relief valve shall be at least 10 % above the operating pressure of the stage and shall not exceed the design pressure.

9.6.3 The final stage relief valve set pressure shall not exceed 10 % above the maximum operating pressure.

9.7 Delivery line non-return valve

9.7.1 A non-return valve shall be fitted to a compressor discharge line to prevent loss of downstream pressure when the compressor is unloading and when the separator is draining.

9.7.2 The valve shall be rated to withstand a pressure of not less than the final relief valve setting (see 9.6.3).

9.8 Gas conditioning

Gas conditioning equipment shall be provided to enable gas quality requirements to be achieved (see 6.2.2).

9.9 Suction line components

9.9.1 A quick acting full-bore relief valve shall be fitted between the non-return device (see 9.3.2) and the compressor inlet if, under fault conditions, the compressor's stage reliefs can cause the pressure between the non-return valve and the compressor to rise to a level above the design pressure of components.

9.9.2 An automatic shut-off valve shall be fitted to isolate the gas supply from the compressor whenever the compressor is not running.

9.9.3 A pressure-reducing valve shall be fitted if it is necessary to drop the supply pressure to a level suitable for the compressor.

9.9.4 High and low gas supply pressure protection shall be fitted to protect the compressor.

9.10 Venting

9.10.1 Where relief valve vents are manifolded together, operation of any relief shall not be impeded.

9.10.2 A relief valve shall vent to atmosphere and the vent pipe shall:

- a) be upward facing and be unimpeded;
- b) discharge at not less than 3 m above ground in a freely exposed position;
- c) be protected against mechanical damage;
- d) be designed to take account of the adverse effects of rain, condensation, foreign bodies and rust (vent flaps and hats shall not be used);

- e) discharge in a safe manner; and
- f) have a defined hazardous area classification.

9.11 Pipework and fittings

9.11.1 Pipework and fittings shall be fixed firmly and secured to prevent disconnection in use that could occur through vibration, rotation and movement.

9.11.2 A gas inlet connection shall have taper threads in accordance with SANS 1109-1 or SANS 1109-2 or flanges in accordance with SANS 1123 (except that the flange may be flat faced) and be in an accessible position.

9.12 Filters and strainers

A filter or strainer shall be fitted on the compressor inlet to protect the compressor and the non-return valves as specified by the compressor manufacturer. Filter pore size will be typically 10 µm to 50 µm. Consideration shall be given to the high-pressure drops likely with the fine filter elements and to the use of differential pressure indication. Filter bodies or elements shall be checked or changed, after commissioning has been completed, as specified by the compressor manufacturer.

9.13 Instrumentation

9.13.1 An hour's run meter shall be provided.

9.13.2 The compressor system shall be fitted with devices such as shut-down switches etc., which will ensure safe operation of the compressor under the following conditions:

- a) low gas inlet pressure (see 8.5);
- b) high gas inlet pressure;
- c) high gas outlet pressure;
- d) high outlet temperature at the final stage;
- e) low oil pressure;
- f) high hydraulic oil temperature (where applicable); and
- g) low hydraulic oil level (where applicable).

Other adverse conditions shall be taken into account, for example, high interstage temperature, moisture, etc.

9.13.3 The safety shut down switches shall be checked by the control logic during the start-up sequences. Only the low oil pressure switch can be overridden during start-up and then only for a period of not exceeding 30 s.

First fault indication shall be provided to identify which fault has caused shutdown.

9.13.4 Resetting of the control system shall be undertaken manually.

The electrical components of a safety system required to remain operable during an emergency shut-down procedure shall be installed external to a compressor enclosure.

SANS 208:2012

Edition 1.1

9.13.5 Indicators shall be provided to show that the electrical supply is "ON" and that the motor is running.

9.13.6 The compressor shall shut down safely in the event of loss of electrical or hydraulic power. Transient losses shall not reset the shut-down condition.

9.13.7 The electrical control panel for the compressor shall not be located within a hazardous zone.

9.13.8 The requirements given in clause 13 shall also be complied with.

9.14 Markings

Each compressor unit shall be marked clearly and permanently with all relevant information, on a data plate.

9.15 Instructions

9.15.1 A compressor shall be provided with comprehensive installation, servicing and user instructions.

9.15.2 A compressor shall be provided with commissioning instructions, which should give guidance on the checking of all safety interlocks, gas seals and lubricants.

10 Storage facility (including ancillaries)

10.1 Storage cylinders

10.1.1 All cylinders shall comply with the requirements of SANS 10019 and be inspected and tested (revalidated) at approved intervals or in the event of suspected damage, by an approved inspection authority (AIA).

10.1.2 Means shall be provided to prevent a pressurized cylinder from being isolated from its pressure relief device. This can be achieved by the removal of an isolation valve handle and the adoption of formal procedures to take an individual cylinder out of service.

10.2 Pressure relief valves

10.2.1 At least one rated pressure relief valve shall be fitted to each manifolded group of cylinders.

10.2.2 At least one rated fusible plug shall be fitted to each manifolded group of cylinders, in order to permit controlled discharge in the event of fire. The fusible plug shall be so located as to provide protection.

10.2.3 A pressure relief valve shall be of a design such that:

- a) it will operate at not more than the maximum design pressure of the system;
- b) the discharge rate is adequate to ensure a controlled depressurization of the system;
- c) its operation does not impair the discharge rate;
- d) if it is adjustable, it can be locked in the set position in order to prevent unauthorized adjustment;
and
- e) it is marked with the set pressure and, where appropriate, the direction of flow.

10.2.4 A relief valve shall not be fitted with a lifting device.

10.2.5 A relief valve shall be fitted to the outlet of a pressure regulator if the downstream fault pressure exceeds the maximum design pressure of the downstream system.

10.2.6 A vent line from a pressure relief valve shall be sized to prevent the discharge rate from being impaired.

10.2.7 All pressure relief valves shall be designed in accordance with 9.10.

11 Valves, shut-down procedures, station pipework and ancillaries

11.1 Emergency isolation

11.1.1 Provision of valves

11.1.1.1 An emergency isolation valve shall be fitted on the outlet from a storage facility and on a compressor outlet to a slow-fill vehicle filling dispenser.

11.1.1.2 An emergency isolation valve shall be of a fast acting type.

11.1.1.3 Valves shall be operated automatically. However, if a manually operated valve is used for emergency isolation, it shall be:

- a) of a fast closing type;
- b) easily operable;
- c) located outside the storage facility area and be readily accessible; and
- d) identified clearly with respect to its position and method of operation.

11.1.1.4 Consideration shall be given to the use of an excess flow valve on the appropriate outlets, particularly where a manually operated emergency isolation valve is used.

11.1.2 Emergency shut-down procedure

11.1.2.1 An emergency shut-down procedure shall be arranged to shut down safely and isolate the filling station gas supply in the event of an emergency.

11.1.2.2 The procedure shall shut down the compressor and isolate the outlets of a storage facility and a compressor outlet to a slow-fill facility, by the operation of the automatic or manual valves prescribed in 11.1.1.

11.1.2.3 The procedure shall involve the activation of emergency switches, which will shut the compressor down automatically and operate the automatic emergency isolation valve. It shall also involve the operation of manually operated emergency isolation valves where fitted.

11.1.2.4 Emergency switches shall be located throughout the filling station and be readily recognized for easy operation in an emergency.

11.1.2.5 Upon operation of the emergency shut-down system, the system shall only be reset, or a manual emergency isolation valve be re-opened, by an authorized person.

11.1.2.6 The emergency shut-down procedure shall be defined clearly and displayed at appropriate locations within the filling station.

11.2 Routine isolation

11.2.1 A manual isolation valve shall be fitted to:

- a) the compressor inlet supply pipework;
- b) the inlet or outlet of a group or bank of storage cylinders; and
- c) the inlet gas supply of a vehicle filling dispenser.

11.2.2 A valve fitted to satisfy the requirements of 11.2.1(b) shall be capable of being locked off or shall require tools to reset it to the open position.

11.2.3 A valve fitted to satisfy the requirements of 11.2.1(a) to 11.2.1(c) (inclusive) shall be identified clearly (by black lettering on a yellow background).

11.2.4 A valve shall be selected for the required high-pressure duty.

11.2.5 If the system has to be depressurized, it shall be done slowly to avoid a cooling effect.

11.2.6 The duty of a valve shall take into account the maximum gas temperature on the compressor outlet.

11.2.7 In the event of a valve closing, the system shall be designed such that the downstream pipework can be re-pressurized slowly.

11.3 High-pressure pipework and ancillaries (pipework downstream of the compressor)

11.3.1 All pipework

11.3.1.1 A compression fitting shall be of stainless steel and shall provide positive retention of the pipe in the fitting without causing significant weakness.

11.3.1.2 The number of flange and compression joints shall be kept to a minimum.

11.3.1.3 Pipework shall be located in a position where it cannot be damaged by moving vehicles.

11.3.1.4 All pipework shall be protected against corrosion and fitted with valved tests and purge points.

11.3.2 Above ground pipework

11.3.2.1 All above ground pipework shall be constructed of seamless stainless steel in accordance with ASTM A 269 types 304 L, 316, 316 L or 321, or an approved standard.

11.3.2.2 Pipework and supports shall be designed to accommodate any pipe movement.

11.3.2.3 Where overhead pipework crosses any vehicle accessway, it shall be positioned at least 4,5 m above ground level and shall be protected against damage from high vehicles.

11.3.2.4 Pipework shall be visually inspected in accordance with the requirements of the relevant national legislation (see foreword).

Amdt 1

11.3.2.5 When pipes pass through sleeves, or apertures in a fire-resistant structure, the space between the pipe and the sleeve or aperture shall be filled-in solid, with a water-resistant, non-abrasive, fire-resistant, non-corrosive material, and the duct or channel shall be completely sealed at positions with fillings of fire resistance at least equal to that of the surrounding structure. Every filling or seal subsequently disturbed shall be restored to its original condition. Provision shall be made for the expansion of pipes between fixed points.

11.3.3 Buried pipework

11.3.3.1 All buried pipework shall be welded and be constructed of carbon steel in accordance with EN 10216-2 or EN 10217-2 or API Spec 5L (grade B) as supplemented and amended, or of stainless steel in accordance with ASTM A 269 type 316 L, or their appropriate equivalent standards. Buried pipework shall be welded and inspected in accordance with SANS 15614-1. Non-destructive testing shall be applied to all the welds. **Amdt 1**

11.3.3.2 All buried pipework shall be protected against corrosion and subsequent damage. Carbon steel pipework shall be coated or wrapped with an anti-corrosive material and cathodically protected in accordance with an approved standard.

11.3.4 Flexible connections

11.3.4.1 Flexible connection(s) shall be suitable for any combination of the extremes of service conditions.

11.3.4.2 A flexible hose shall be inspected regularly according to use but at least every 12 months, by a competent person and shall be compatible with the product being used.

11.4 Pressure gauges

11.4.1 A pressure gauge shall comply with the requirements of SANS 1062.

11.4.2 A gauge shall be graduated to approximately double the operating pressure but in no case to less than 1,2 times the pressure at which an applicable pressure relief valve is set to operate (see 10.2).

11.4.3 A pressure gauge shall be fitted to each cylinder storage unit.

11.4.4 A gauge shall be fitted with a snubber if pulsations or sudden changes in flow rate cause damage.

11.4.5 Gauges shall be re-calibrated at least every three years.

11.5 Pressure testing

11.5.1 Pipework, which, on installation, has been subjected to welding, bending, forming or deformation, shall be hydrostatically tested in accordance with annex D.

11.5.2 Pipework which has been installed in pre-assembled equipment or which has been fabricated by welding, bending, forming or deformation shall either have been shown to have been hydrostatically tested in accordance with the equipment manufacturer's standard procedures to not less than $1,3 \times$ maximum operating pressure, the evidence being acceptable to the responsible engineer, or shall be hydrostatically tested in accordance with annex D.

11.5.3 The completed installation shall be pneumatically tested in accordance with annex D.

11.6 Gas detection system

11.6.1 Where a compressor or storage facility (or both) is located in a housing or enclosure, consideration shall be given to the installation of a reliable and fail-safe gas detection system, to complement the ventilation system (see 7.4.2), that is interlocked into the control system in order to cause shut-down and alert personnel if leakage of gas is detected.

11.6.2 A gas detection system shall not be regarded as a substitute for good ventilation. Proper ventilation shall always be provided.

| **11.6.3** Where a gas detector is used, it shall comply with the requirements of EN 60079-29-1.

Amdt 1

| **11.6.4** Selection and installation of a gas detector shall be in accordance with EN 60079-29-2.

Amdt 1

12 Vehicle filling dispenser

12.1 Dispensing unit

| **12.1.1** When a metering device is fitted, it shall comply with the requirements of the relevant national legislation (see foreword).

Amdt 1

12.1.2 The dispenser unit shall control the flow and pressure of gas supplied to the filling nozzle. On a slow-fill facility, this may be done upstream of the dispenser.

12.1.3 The pressure of the gas supplied from the dispenser unit shall not exceed the maximum filling pressure of a vehicle which it is intended to supply.

12.1.4 All electrical equipment and wiring on the dispenser unit shall be classified under hazardous area Zone 2.

12.1.5 The dispensing unit at a fast-fill station shall be deactivated automatically when:

a) the dispensed filling pressure is reached; or

b) a manual flow control valve is operated.

12.1.6 Each filling point shall be protected against a vehicle driving off with the filling hose still connected, by the inclusion of a breakaway quick-closing device, which shall separate and isolate the gas supply in a safe manner. The maximum breakaway force shall be less than 200 N in any direction.

12.2 Filling hose

12.2.1 The length of the filling hose assembly shall be the minimum required to allow a safe filling operation.

12.2.2 The filling hose shall be flexible and resistant to corrosion and mechanical damage. It shall be supported to prevent kinking and abrasion.

12.2.3 The hose shall be marked distinctly along its length to indicate that it contains natural gas.

12.2.4 The dispensing end of the hose shall incorporate a device which prevents the closing of the vehicle boot or bonnet from damaging the hose.

12.2.5 Continuous electrical continuity to earth shall be provided along the hose from the nozzle to the dispensing unit.

12.2.6 Filling hoses shall be inspected for damage at periods not exceeding three months.

12.3 Filling nozzle

12.3.1 The filling nozzle shall be equipped with means to:

- a) maintain a positive gas-tight seal with the vehicle fill connection, via a quick release mechanism;
- b) effect positive shut-off;
- c) prevent discharge of natural gas, other than when a positive connection is made to the vehicle fill point; and
- d) minimize or, preferably, eliminate the release of natural gas when the nozzle is disconnected from the vehicle filling point.

12.3.2 The nozzle shall be of an acceptable type and its operating mode shall be compatible with the vehicle's fixed filling connection. Intermediate adapter fittings shall not be used. (A recommended filling nozzle design is given in annex E.)

12.3.3 Where the filling valve is not an integral part of the nozzle, the nozzle shall be held in a protective cradle when not in use. The cradle design shall be such that the nozzle will have to be removed before the filling valve can be operated.

12.4 Dispensing control system

12.4.1 The control system shall operate the compressor in such a manner as to maintain the pressure in the storage facility for any station dispensing fuel on a fast-fill basis.

12.4.2 The control system shall provide control of a cascade dispensing sequence from the gas storage, in order to maintain an acceptable dispensing rate.

12.4.3 For slow-fill facilities, the control system shall ensure that the fill pressure supplied to a vehicle does not exceed the maximum operating pressure of that vehicle's fuel system. When a connected vehicle has been filled to its maximum operating pressure, the control system shall stop the dispensing unit.

12.4.4 Consideration should be given to the need to compensate for variations in ambient temperature affecting the dispensed volume.

13 Electrical equipment and wiring

13.1 All electrical equipment and wiring used shall comply with the requirements of SANS 10142-1. All electrical equipment shall be designed and manufactured in accordance with an approved standard. The installation, inspection and maintenance of electrical equipment shall be in accordance with SANS 10086-1 or SANS 10089-2.

13.2 Electrical components of safety systems that are required to remain operable under emergency shut-down conditions shall be located and connected in a suitable manner.

14 Testing, purging and commissioning

14.1 General

14.1.1 All equipment shall be tested, purged and commissioned.

14.1.2 The pressure testing procedures given in annex D shall apply.

14.2 Recommended procedures

A pressure test of the pipework equipment and a purge and flare points shall be carried out before a purge admitting fuel gas or inert gas. The purging procedure is given in annex F.

15 Symbolic safety signs

The appropriate symbolic safety signs that comply with SANS 1186-1 shall be erected adjacent to all filling sites, for example:

<p style="text-align: center;">Compressed natural gas Extremely flammable Switch off engine Apply handbrake No smoking – No naked lights Switch off cellular phones</p>

Pictograms should be used wherever possible. Additional notice shall be installed at the emergency switch or integrated into the existing emergency switch notice:

<p style="text-align: center;">Emergency CNG Pump – Switch off here</p>

16 Prevention and control of fires involving CNG

16.1 General information

CNG vapours become flammable when mixed with air. Severe fires and explosions can result when such mixtures ignite. The following information is given as a guide to users of CNG:

- a) A liquid leak from a CNG container will generate a very large volume of gas vapour. Liquid leaks are therefore a much greater source of hazard than vapour leaks.
- b) CNG vapours do not disperse easily and, being heavier than air, will hug ground contours and will tend to flow along natural paths and fill depressions, ditches and pits. In favourable conditions, flammable vapours can travel for long distances from the point of release. They might also enter a building and be contained there, particularly in basements and cellars. Vapour dispersal can be accelerated by water spray or wind.
- c) Small fires involving CNG can usually be readily extinguished by dry chemical-type fire extinguishers. Such extinguishers shall be installed at the filling and storage area.
- d) Empty containers that are left open will admit air. In this way an ignitable mixture that can be very hazardous is formed.

16.2 Tank installation

Fire prevention and control measures shall comply with the requirements of SANS 10087-1 and SANS 10087-3.

16.3 Fire extinguishers

A 9 kg multipurpose dry chemical powder (DCP) fire extinguisher shall be provided per pump island.

16.4 Leakage of gas

If a leak develops in:

- a) a filling container, both the local fire authority and the supplier shall be informed immediately and remedial action taken; or
- b) the supply line, endeavour to close the supply valve on the container and take remedial action.

16.5 Action in emergency

16.5.1 Gas leakage without fire

Unless remedial action, such as closing the valve, can be effected on the spot, a leaking container shall be identified and handled as follows:

Means shall be included in the pipework design to isolate, by remote operation, sections in the event of a fire or other emergency. This can be by remotely operated valves either on the vessel liquid outlet or the pump outlet and on the pipework to and from the dispenser. These valves shall fail into the closed position and, if they are solenoid valves, shall be able to operate over the full range of temperatures. Solenoid valves shall not rely on a differential pressure across the valve to achieve closure.

16.5.2 Gas leakage with fire

16.5.2.1 Unless there is a danger of flames impinging on other containers, no attempt shall be made to extinguish a fire before the source of leakage has been determined and it is known that the leakage can be stopped after the fire has been extinguished. For example, a fire occurring at the outlet of a container valve can be extinguished by means of a portable extinguisher, provided that the valve is then closed immediately or the container is promptly removed to a place where gas leakage will not result in a subsequent explosion.

16.5.2.2 Where it is not possible to extinguish the fire and either to stop the leakage or to remove the leaking container promptly, water spray shall be used to keep cool all the containers in the vicinity of the burning fire.

16.5.3 Containers exposed to fire

16.5.3.1 If a container that does not incorporate a safety relief is exposed to severe heat radiation, adequate volumes of water sprayed onto the container will cool the liquids and will, in all probability, prevent hydraulic rupturing that could result from over-pressurization. Nevertheless, an assessment shall be made of the risks of possible rupture since such rupture occurs with explosive force and can endanger life and property over a considerable area. The impingement of flames, for an unknown period, on containers shall be regarded as an extremely dangerous condition that necessitates immediate evacuation of the area.

NOTE Evacuation distances will depend on the total volume of gas involved. Evacuation distances of up to 600 m should be considered.

SANS 208:2012

Edition 1.1

16.5.3.2 Containers not involved in or affected by the fire shall be removed to a safe area or, alternatively, if this is not possible, such containers shall be kept cool by spraying them gently with adequate quantities of water. If containers equipped with relief devices are exposed to a severe fire, steps can and shall be taken to avoid jets of gas that are escaping via these devices (for example, by standing well clear of the containers), since such jets might extend as far as 10 m.

17 Training

A written emergency procedure shall be provided at the site and all staff shall be fully trained in the dangers of CNG and on the action to be taken in the case of an emergency during storage, delivery and dispensing. Staff training records shall be kept on site.

Training shall include how to fill a vehicle and what to do if:

a) a customer drives away whilst still connected;

NOTE Some pullaway couplings can be reconnected with the hose still under pressure. The operator should not do this unless trained to do so. Whatever type of pullaway or breakaway is used, the installation, and particularly hoses, should be checked before the system is returned to service.

b) a customer arrives at the unit with a different fill coupling than the nozzle supplied;

c) excess product is lost on disconnection;

d) the dispenser is run into;

e) a user receives a cold burn;

f) there is a problem during tanker delivery.

Annex A

(normative)

Gas quality

A.1 Gas supplied to the filling station

A.1.1 Properties related to containers and vehicle fuel systems corrosion

Natural gas for vehicle fuel use is typically stored in a high-density gaseous state at CNG fuelling stations at peak tank pressures of 24,822 kPa to 34,475 kPa and on board vehicles at peak tank pressures of 20,685 kPa to 24,822 kPa in cylinders made of metal, for example, steel or aluminium. Cylinders have metal or non-metallic liners with resin-reinforced filament winding. It is essential that all safety factors shall provide a safety margin for rupture pressure as well as resistance to corrosion, fatigue, fire, vibration and mechanical damage. Cylinder failures can be caused by corrosion or corrosion-related damage, i.e. stress corrosion cracking (essentially hydrogen embrittlement) or corrosion fatigue.

Specific fuel components can impact cylinder integrity. The most critical potential issue is crack growth due to corrosion fatigue. This process occurs due to the combined action of corrosion agents in natural gas – hydrogen sulfide, carbon dioxide, water (or water vapour) – and the pressure cylinder associated with periodically expending and replenishing the fuel storage cylinder.

A.1.2 Pressure water dew point temperature

The pressure water dew point temperature of the fuel shall be compatible with the specific geographical location in which the vehicle will operate and shall be set such that condensation of water will not occur in the storage cylinder at the maximum operating container pressure. The local pressure dew point temperature of the fuel shall be defined as 5,6 °C below the monthly lowest dry-bulb temperature in South Africa. The margin of 5,6 °C is intended to provide some allowance for expansion cooling as gas flows throughout the fuel system components. Expansion cooling will generally lead to greater temperature decreases than 5,6 °C. Hence freezing in the fuel system might occur if the fuel gas is not extremely dry.

The gas supplier or station shall determine the most appropriate method to maintain the pressure water dew point limit. Pressure water dew point is determined by ASTM D 1142.

A.1.3 Hydrogen sulfide concentration

Given that the corrosive environment is controlled via the limited water concentration per dew point temperature, no limitations are required on the concentration of hydrogen sulfide (H₂S) for this purpose. However, the total content of sulfur compounds, including odorants, shall be limited to 1,0 g/2,83 m³ mass to avoid excessive exhaust catalyst poisoning. Hydrogen sulfide concentration is determined by ASTM D 1142.

A.1.4 Carbon dioxide concentration

Given that the corrosive environment is controlled via the limited water concentration per dew point temperature, no limitations are required on the concentration of carbon dioxide (CO₂) for this purpose. However, a limit of 3,0 % CO₂ by volume is recommended to help maintain stoichiometry. Carbon dioxide concentration is determined by ASTM D 1945.

A.1.5 Methanol concentration

No methanol shall be added to natural gas at the CNG fuelling station. Methanol can cause corrosion of natural gas cylinders and deterioration of fuel systems components. Methanol is not needed if the pressure water dew point temperature of the stored gas is maintained within the recommended limits.

A.1.6 Oxygen concentration

Given that the corrosive environment is controlled via the limited water concentration as per dew point temperature, no limitations are required on the concentration of oxygen (O₂) for the control of corrosion. At no time shall the oxygen level produce a mixture within the flammability limits of the fuel. Current automotive industry experience indicates closed-loop engine controls can be used to maintain stoichiometry using pipeline quality gas. Oxygen concentration is determined by ASTM D 1945.

A.1.7 Pressure hydrocarbon dew point temperature

Some locally distributed natural gases can contain mixtures of propane and air used to meet peak demand requirements. Propane is therefore the predominant condensable hydrocarbon of concern. Propane has a comparably low vapour pressure and, if present in significant quantities, will form a liquid phase at elevated pressures and low temperatures. Fuel variability due to revaporization of this liquid condensate at reduced tank pressures can lead to reduced vehicle performance. To minimize these occurrences, the composition of natural gas shall be such that the original gaseous storage volume will form less than 1 % of a liquid condensate at the lowest ambient temperatures and gas storage pressures between 5 516 kPa and 8 274 kPa at which maximum condensation occurs depending on gas composition.

The amount of propane shall be compatible with the specific geographical region or temperatures in which the vehicle will operate and shall be set such that less than 1 % hydrocarbon condensate will form at the dry-bulb temperature. Propane concentration is determined by ASTM D 1945.

A.2 Natural gas odorant

Natural gas introduced into a CNG fuelling station or vehicle shall have a distinctive odour potent enough for its presence to be detected down to a concentration in air of not over 1/5 of the lower limit of flammability. This is approximately 1,0 % gas in air by volume. Gas odorant shall be applied before the gas reaches the compressor.

Annex B
(normative)

Instructions for filling

B.1 Filling procedure for a typical fast-fill

B.1.1 Remove the dust plug from the vehicle filling connection.

B.1.2 Attach the filling hose to the fill point.

B.1.3 On completion of the fill, carefully disconnect the filling hose. A small escape of gas from the filling nozzle might occur at this time.

B.1.4 Return the hose to the correct position on the dispenser.

B.1.5 Refit the dust plug.

B.2 Filling procedure for a typical slow-fill

B.2.1 Remove the dust plug from the vehicle filling connection.

B.2.2 Attach the filling hose to the fill point.

B.2.3 Open the fuel valve on the fill post.

B.2.4 After the expected fill time has elapsed and the vehicle cylinder is full, close the fuel valve on the fill post.

B.2.5 Carefully disconnect the filling hose. A small escape of gas from the filling nozzle might occur at this time.

B.2.6 Return the hose to the correct position on the fill post.

B.2.7 Refit the dust plug.

Annex C

(normative)

Emergency procedures for mechanical ventilation of enclosures

C.1 To comply with the requirements of 7.4.3, an enclosure will need to have a mechanical ventilation system designed to include an emergency procedure in the event of system failure. The factors involved in choosing a design will vary depending upon the installation. Such factors include the gas inlet pressure, the compressor gas outlet pressure, the "potential gas release" (see 7.4.2), the volume of gas within the enclosure, etc. A full analysis of the procedures needed to ensure compliance with 7.4.3 will reveal the design requirements. Additional features such as a gas detection system could be needed.

C.2 A typical procedure shall, upon failure of the system, carry out the following:

- a) shut down the compressor and any ancillaries within the enclosure;
- b) shut down the gas supply to and from the pipework in the enclosure;
- c) prevent start up of the compressor and any ancillaries within the enclosure until the fault is rectified; or
- d) initiate an alarm to alert responsible personnel.

C.3 If a gas detection system is considered to be essential to the design, then in the event of detection of gas, the emergency procedure shall need to:

- a) isolate all electrical equipment within the enclosure (noting that electrical components of safety systems required to remain operable shall be outside the enclosure); and
- b) safely vent the gas contained in the system within the enclosure at a suitable rate down to an appropriate pressure.

Annex D

(normative)

Hydrostatic and pneumatic testing

D.1 Safety precautions

D.1.1 This test procedure requires the implementation of both hydrostatic and pneumatic tests on the components of the installation and the installation itself. The safety of all persons, whether or not involved in the testing, is of paramount importance. No procedure, which would violate this concept, shall be carried out.

D.1.2 The engineer shall be consulted at the pipework design stage on the adequacy of the safety precautions proposed by the contractor. The safety precautions shall ensure that no person will be exposed to injury should any part of the pipework system fail during the test operation. The safety precautions shall be subjected to the written approval of the engineer before the test, with particular reference to the following:

- a) protection of adjacent pipework and equipment;
- b) extent of the area cleared for test safety purposes;
- c) adequacy of any applicable non-destructive testing carried out before the test, including testing carried out previously by others;
- d) resistance of the materials to fast fracture;
- e) procedure to prevent local chilling during filling and emptying; and
- f) the extent of remote monitoring provided during test.

D.1.3 All personnel engaged on the test shall be fully instructed regarding the possible hazards involved in the testing, particular attention being paid to securing pipes to prevent whip following any failure.

D.1.4 Precautions shall be taken to protect any adjacent pipework or equipment from the effects of failure of the pipework.

D.1.5 For hydrostatic testing, the contamination of test water shall be avoided unless special disposal arrangements have been made.

D.1.6 A test area shall be defined and agreed with the engineer. This test area will include all enclosed areas through which the pipework runs and local access ways. The boundaries of the test area shall be defined by marker tapes. Proper warning notices shall be displayed, which read "WARNING — PIPEWORK UNDER TEST" at all points where access can be gained to the test area.

D.1.7 Attention is drawn to the fact that if a test medium, such as compressed nitrogen, is reduced to the test pressure from high pressure storage, its temperature will fall. The test arrangements shall be such that the temperature of the medium entering the pipework under test is not lower than the agreed test temperature. In order to prevent condensation within the pipework, the temperature of the test medium shall not be allowed to fall below the dew point at the corresponding test pressure.

D.1.8 Before a pneumatic test, all welds shall be subjected to non-destructive testing.

D.2 Hydrostatic strength/pressure test of system components

D.2.1 General

Hydrostatic strength or pressure testing is intended to prove the strength of the system components and pipework, at 1,5 times the maximum operating pressure.

D.2.2 Apparatus

D.2.2.1 Standard test gauge complying with SANS 1062, of at least 150 mm dial face diameter, checked for calibration before use against the calibration certificate issued by the manufacturer of the gauge.

D.2.2.2 Relief valve set such that the maximum test pressure cannot be exceeded.

D.2.2.3 Control valves.

D.2.2.4 Pressurizing pump.

D.2.3 Water

To avoid the possibility of subsequent failure in service of austenitic stainless steel pipework caused by stress corrosion cracking or pitting, use only potable water having a chloride content less than 30 mg/L.

D.2.4 Procedure

D.2.4.1 Observe all relevant safety precautions outlined in D.1.

D.2.4.2 Connect the system to be tested to the water supply using suitable control valves, the standard test gauge and the relief valve, and fill the system with water. It might be necessary to provide draining facilities, especially at low points in the system.

D.2.4.3 Increase the test pressure gradually, in increments of 10 % of the maximum test pressure, to 1,5 times the maximum operating pressure, then stop the pressurizing pump. During this period, plot the pressure reading against time elapsed.

D.2.4.4 On reaching the maximum test pressure, continue to plot pressure against time elapsed for a minimum of 4 h, recording any pressure variation. The pressure shall never exceed a value 5 % above the nominal test pressure.

A satisfactory strength test, to be proved by the subsequent pneumatic test, is indicated by the lack of a sudden drop in pressure.

D.2.4.5 Completely empty the system components of water, using a procedure issued by the installer of the equipment.

D.2.4.6 Thoroughly dry the system components. Do not use methanol to dry the pipework. If necessary, an alternative, safe method to dry the pipework will be required.

D.3 Pneumatic leak test of the complete system

D.3.1 General

After successful completion of a hydrostatic strength or pressure test and following the complete refitting of separately tested impulse pipework together with other equipment, subject the completed system to a pneumatic leak test.

D.3.2 Materials

D.3.2.1 Compressed air that is cooled, oil free and dried after compression and before injection into the pipework system.

D.3.2.2 Acceptable soap solution that is compatible with the type of austenitic stainless steel material used in the construction of the pipework and fittings.

D.3.3 Procedure

D.3.3.1 Observe all safety precautions outlined in D.1.

D.3.3.2 Subject the completed pipework system to an initial leak test using a test medium of nitrogen or dry, oil-free air (see D.3.2.1) at a pressure of 2 bar, to determine if major leaks exist in the system.

D.3.3.3 Pressurize the installation slowly up to the final test pressure of 1,1 times the maximum operating pressure of the system and hold for a period adequate to ensure that the installation can be thoroughly inspected.

D.3.3.4 Check all joints, flanges and glands on valves, pipework and fittings, for leaks, using an appropriate leak detection fluid (see D.3.2.2). Correct any leak detected and then repeat the test procedure.

D.3.4 Completion

After completion of the test and release of pressure, dry the system by passing a large quantity of dry air or nitrogen, with a dew point below $-40\text{ }^{\circ}\text{C}$, through the system until the dew point of the exit gas is $-40\text{ }^{\circ}\text{C}$. Ensure that there are no residual pockets of water, then carry out a further dew point check. The dew point shall be $-40\text{ }^{\circ}\text{C}$ or less for the system to be acceptable.

Annex E
(informative)

Filling nozzle design

Figure E.1 gives a typical filling nozzle design.

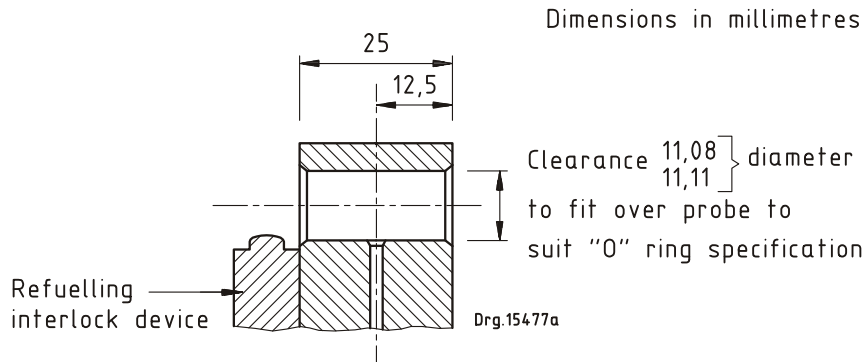

Female (the fitting on the vehicle)

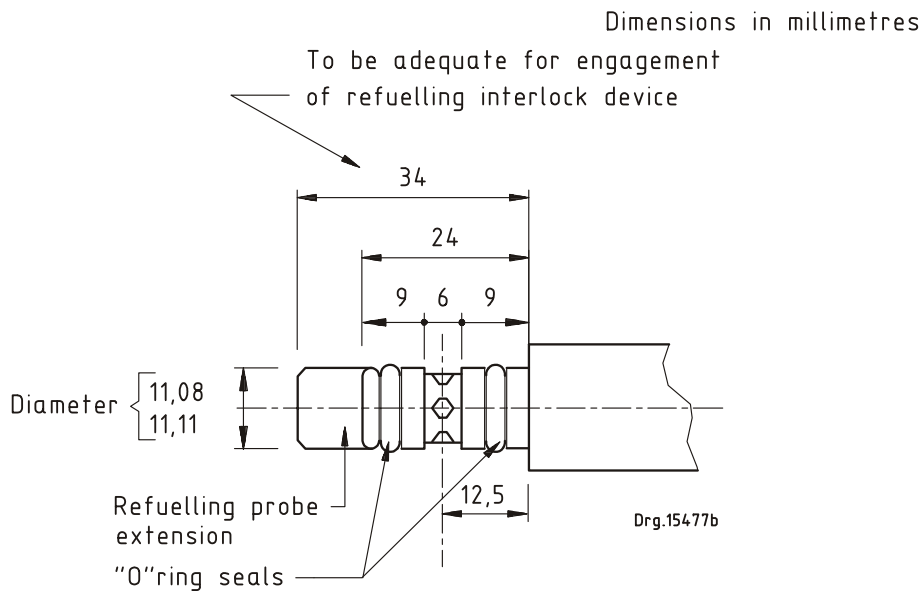

Male probe (the fitting on the refuelling hose)

Figure E.1 — Typical 20 MPa to 30 MPa CNG filling nozzle

Annex F

(normative)

Purging

F.1 General

The procedure requires the implementation of purging procedures following pressure testing. The environmental impact of methane in the atmosphere shall be considered and, consequently, purge gas shall be flared rather than purged to atmosphere.

F.2 Safety precautions

The following safety precautions shall be taken into consideration:

- a) Purging shall not be commenced without a full knowledge of the pipework and ancillary equipment.
- b) Primary gas meters shall be purged under the supervision of a competent person nominated by the gas supplier.
- c) In all but the most simple purge operations, a written procedure appropriate to the installation shall be prepared and followed.
- d) Precautions shall be taken to reduce, as far as practical, the possible hazards arising from venting, for example by avoiding venting close to property or potential sources of ignition such as electrical plant and equipment. Warning notices, in particular "No smoking" and "No naked lights", shall be displayed prominently around the area where purging is to take place. No work shall be done on any section of the plant undergoing purging.
- e) Fire extinguishers shall be made available on the site during the purging operation.
- f) Purging shall be carried out continuously. If there is any discontinuity, the purge shall be abandoned and the complete operation repeated.
- g) When conducting an inert gas or air purge, precautions shall be taken to prevent the purge gases from entering the gas suppliers' gas distribution network.

F.3 Procedure

F.3.1 Following a satisfactory pressure test, lower the pressure in the pipework to be purged to a level that will admit safely the purge gas to meet the criteria of the purge.

F.3.2 Carry out purging from gas to air or air to gas, provided a minimum velocity within all the associated pipework and equipment is maintained at not less than 0,6 m/s.

F.3.3 If the velocity stated above cannot be maintained, then consider purging from an inert gas route, using nitrogen.

Bibliography

~~ASTM A 269, Standard specification for seamless and welded austenitic stainless steel tubing for general service. Amdt 1~~

~~ASTM D 1945, Standard test method for analysis of natural gas by gas chromatography. Amdt 1~~

SAE J 1616, *Recommended practice for compressed natural gas vehicle fuel.*

The Institution of Gas Engineers Utilization Procedures (IGE/UP/5), *Natural gas vehicles – Part 1: Design and installation of filling stations.*

SABS – Standards Division

The objective of the SABS Standards Division is to develop, promote and maintain South African National Standards. This objective is incorporated in the Standards Act, 2008 (Act No. 8 of 2008).

Amendments and Revisions

South African National Standards are updated by amendment or revision. Users of South African National Standards should ensure that they possess the latest amendments or editions.

The SABS continuously strives to improve the quality of its products and services and would therefore be grateful if anyone finding an inaccuracy or ambiguity while using this standard would inform the secretary of the technical committee responsible, the identity of which can be found in the foreword.

Tel: +27 (0) 12 428 6666 Fax: +27 (0) 12 428 6928

The SABS offers an individual notification service, which ensures that subscribers automatically receive notification regarding amendments and revisions to South African National Standards.

Tel: +27 (0) 12 428 6883 Fax: +27 (0) 12 428 6928 E-mail: sales@sabs.co.za

Buying Standards

Contact the Sales Office for South African and international standards, which are available in both electronic and hardcopy format.

Tel: +27 (0) 12 428 6883 Fax: +27 (0) 12 428 6928 E-mail: sales@sabs.co.za

South African National Standards are also available online from the SABS website <http://www.sabs.co.za>

Information on Standards

The Standards Information Centre provides a wide range of standards-related information on both national and international standards, and is the official WTO/TBT enquiry point for South Africa. The Centre also offers an individual updating service called INFOPLUS, which ensures that subscribers automatically receive notification regarding amendments to, and revisions of, international standards.

Tel: +27 (0) 12 428 6666 Fax: +27 (0) 12 428 6928 E-mail: info@sabs.co.za

Copyright

The copyright in a South African National Standard or any other publication published by the SABS Standards Division vests in the SABS. Unless exemption has been granted, no extract may be reproduced, stored in a retrieval system or transmitted in any form or by any means without prior written permission from the SABS Standards Division. This does not preclude the free use, in the course of implementing the standard, of necessary details such as symbols, and size, type or grade designations. If these details are to be used for any purpose other than implementation, prior written permission must be obtained.

Details and advice can be obtained from the Senior Manager.

Tel: +27 (0) 12 428 6666 Fax: +27 (0) 12 428 6928 E-mail: info@sabs.co.za