

# **SOUTH AFRICAN NATIONAL STANDARD**

## **Industrial furnaces and associated processing equipment — Safety**

### **Part 2: Combustion and fuel handling systems**

This national standard is the modified implementation of ISO 13577-2:2014, and is adopted with the permission of the international Organization for Standardization.

**WARNING**  
This document references other documents normatively.



This page has been left blank intentionally



## **COPYRIGHT PROTECTED DOCUMENT**

© SABS

In terms of the Standards Act 8 of 2008, the copyright in all South African National Standards or any other publications published by the SABS Standards Division, vests in the SABS. Any use of South African National Standards is limited to use specifically prescribed by the SABS. In the case of a South African National Standard based on an international standard, ownership of the copyright vests in the organization from which the SABS adopted the standard, whether it be under licence or membership agreement. The SABS is obliged to protect such copyright and is authorized to make the relevant international organization aware of any misuse thereof. Unless exemption has been granted, no extract or full text of any South African National Standard may be copied, reproduced, stored in a retrieval system or transmitted in any form or by any means without prior written permission from the SABS Standards Division. This does not preclude the free use, in the course of implementing the standard, of necessary details such as symbols, and size, type or grade designations. If these details are to be used for any purpose other than implementation, prior written permission must be obtained.

Details, advice and limitations of use can be obtained from the Manager: Standards Sales and Information Services. Tel: +27 (0) 12 428 6883 email: [sales@sabs.co.za](mailto:sales@sabs.co.za)

### **SABS – Standards Division**

The objective of the SABS Standards Division is to develop, promote and maintain South African National Standards. This objective is incorporated in the Standards Act, 2008 (Act No. 8 of 2008).

The SABS continuously strives to improve the quality of its products and services and would therefore be grateful if anyone finding an inaccuracy or ambiguity while using this standard would inform the secretary of the technical committee responsible, the identity of which can be found in the foreword.

### **Buying Standards**

Contact the Sales Office for South African and international standards, which are available in both electronic and hard copy format. Tel: +27 (0) 12 428 6883 email: [sales@sabs.co.za](mailto:sales@sabs.co.za)

South African National Standards are also available online from the SABS Webstore [www.store.sabs.co.za](http://www.store.sabs.co.za)

### **Information on Standards**

SABS Customer Services provide comprehensive standards-related information on national, regional and international standards. Tel: +27 (0) 12 428 7911 / 0861 27 7227 email: [info@sabs.co.za](mailto:info@sabs.co.za)

# SANS 13577-2:2023

Edition 1

## Table of changes

Change No.	Date	Scope

## Foreword

This South African standard was prepared by National Committee SABS/TC 1019, *Gas supply, handling and control (fuel, industrial and medical gases)*, in accordance with procedures of the South African Bureau of Standards, in compliance with annex 3 of the WTO/TBT agreement.

This document was approved for publication in February 2023.

This National Standard is the modified adoption of ISO 13577-2:2014. Details of the modifications are given in national annex AA (inserted at the end of the document).

Reference is made in the introduction (a) and (c) in Annex AA to the "relevant national legislation". In South Africa this means the Electrical Installations Regulations of the Occupational Health and Safety Act, 1993 (Act No. 85 of 1993).

Reference is made in the introduction (b) and (d) in Annex AA to the "relevant national legislation". In South Africa this means the Pressure Equipment Regulations in the Occupational Health and Safety Act, 1993 (Act No. 85 of 1993).

Reference is made in the introduction, 4.2.1.1, 4.2.1.7 and in Annex AA to the "relevant national legislation". In South Africa this means the Pressure Equipment Regulations.

Reference is made in 6.3.1 of Annex AA to the "relevant national legislation". In South Africa this means the Occupational Health and Safety Act, 1993 (Act No. 85 of 1993).

Reference is made in 5.2.5.5 of Annex AA to the "relevant national legislation". In South Africa this means the Environmental Regulation for Workplaces (section 5: Ventilation) in terms of the Occupational Health and Safety Act, 1993 (Act No. 85 of 1993).

**Compliance with this document cannot confer immunity from legal obligations.**

INTERNATIONAL  
STANDARD

ISO  
13577-2

First edition  
2014-09-15

---

---

**Industrial furnaces and associated  
processing equipment — Safety —  
Part 2:  
Combustion and fuel handling systems**

*Fours industriels et équipements associés — Sécurité —*

*Partie 2: Équipement de combustion et de manutention des  
combustibles*



Reference number  
ISO 13577-2:2014(E)

© ISO 2014



**COPYRIGHT PROTECTED DOCUMENT**

© ISO 2014

All rights reserved. Unless otherwise specified, no part of this publication may be reproduced or utilized otherwise in any form or by any means, electronic or mechanical, including photocopying, or posting on the internet or an intranet, without prior written permission. Permission can be requested from either ISO at the address below or ISO's member body in the country of the requester.

ISO copyright office  
Case postale 56 • CH-1211 Geneva 20  
Tel. + 41 22 749 01 11  
Fax + 41 22 749 09 47  
E-mail [copyright@iso.org](mailto:copyright@iso.org)  
Web [www.iso.org](http://www.iso.org)

Published in Switzerland

# Contents

Page

<b>Foreword</b> .....	<b>iv</b>
<b>Introduction</b> .....	<b>v</b>
<b>1 Scope</b> .....	<b>1</b>
<b>2 Normative references</b> .....	<b>2</b>
<b>3 Terms and definitions</b> .....	<b>3</b>
<b>4 Safety requirements, measures and verification means</b> .....	<b>3</b>
4.1 General.....	3
4.2 Gaseous fuels.....	3
4.3 Liquid fuels.....	18
4.4 Multiple fuels.....	29
4.5 Oxygen or oxygen-enriched combustion air (OOECA).....	30
<b>5 Verification of the safety requirements and/or measures</b> .....	<b>32</b>
<b>6 Information for Use</b> .....	<b>37</b>
6.1 General.....	37
6.2 Marking.....	37
6.3 Instruction handbook.....	37
<b>Annex A (informative) List of significant hazards</b> .....	<b>40</b>
<b>Annex B (informative) Typical examples of fuels</b> .....	<b>42</b>
<b>Annex C (informative) Typical example of piping and components</b> .....	<b>43</b>
<b>Annex D (informative) Methods for burner start-up</b> .....	<b>55</b>
<b>Annex E (normative) Maximum allowed pressure</b> .....	<b>63</b>
<b>Annex F (informative) Examples for the determination of safety integrity level (SIL) using the risk graph method</b> .....	<b>68</b>
<b>Annex G (normative) Requirements specific to Japan</b> .....	<b>79</b>
<b>Annex H (normative) Requirements specific to the USA</b> .....	<b>85</b>
<b>Annex I (normative) Requirements for Europe and associated countries</b> .....	<b>91</b>
<b>Bibliography</b> .....	<b>96</b>

## ISO 13577-2:2014(E)

## Foreword

ISO (the International Organization for Standardization) is a worldwide federation of national standards bodies (ISO member bodies). The work of preparing International Standards is normally carried out through ISO technical committees. Each member body interested in a subject for which a technical committee has been established has the right to be represented on that committee. International organizations, governmental and non-governmental, in liaison with ISO, also take part in the work. ISO collaborates closely with the International Electrotechnical Commission (IEC) on all matters of electrotechnical standardization.

The procedures used to develop this document and those intended for its further maintenance are described in the ISO/IEC Directives, Part 1. In particular the different approval criteria needed for the different types of ISO documents should be noted. This document was drafted in accordance with the editorial rules of the ISO/IEC Directives, Part 2 (see [www.iso.org/directives](http://www.iso.org/directives)).

Attention is drawn to the possibility that some of the elements of this document may be the subject of patent rights. ISO shall not be held responsible for identifying any or all such patent rights. Details of any patent rights identified during the development of the document will be in the Introduction and/or on the ISO list of patent declarations received (see [www.iso.org/patents](http://www.iso.org/patents)).

Any trade name used in this document is information given for the convenience of users and does not constitute an endorsement.

For an explanation on the meaning of ISO specific terms and expressions related to conformity assessment, as well as information about ISO's adherence to the WTO principles in the Technical Barriers to Trade (TBT) see the following URL: Foreword - Supplementary information

The committee responsible for this document is ISO/TC 244, *Industrial furnaces and associated processing equipment*.

ISO 13577 consists of the following parts, under the general title *Industrial furnaces and associated processing equipment — Safety*:

- *Part 1: General requirements*
- *Part 2: Combustion and fuel handling systems*
- *Part 3: Generation and use of protective and reactive atmosphere gases*
- *Part 4: Protective systems*

## Introduction

This document is a type-C standard as defined in ISO 12100.

The machinery concerned and the extent to which hazards, hazardous situations or hazardous events are covered, is indicated in the Scope of this document.

When requirements of this type-C standard are different from those which are stated in type-A or -B standards, the requirements of this type-C standard take precedence over the requirements of the other standards, for machines that have been designed and built according to the requirements of this type-C standard.

This part of ISO 13577 assumes that the equipment is not creating any potentially explosive atmosphere and is located in a normally ventilated area.

Compliance with product standards e.g. ISO 22967 or ISO 22968 is not sufficient to ensure the minimum safety requirements for industrial furnaces and associated processing equipment (TPE). This part of ISO 13577 shall always have priority for TPE.

Industrial furnaces and associated processing equipment (TPE) generally consists of the following components:

- processing chamber (e.g. steel construction with lining and/or refractory);
- heating systems;
- protective system;
- control and instrumentation system / operator-control level.

ISO 13577-1 provides the general safety requirements common to TPE. This part of ISO 13577 details in addition specific safety requirements for combustion and fuel handling systems that are part of TPE as listed in the Scope.

NOTE As stated in its scope, ISO 13577-1 does not cover blast furnaces, converters (in steel plants), boilers and equipment not covered by ISO 12100.

The requirements for protective systems are specified in ISO 13577-4.

If a general requirement of ISO 13577-1 counters requirements in this part of ISO 13577, the requirements of this part of ISO 13577 take precedence.

The requirements for reducing hazards from noise are given in ISO 13577-1.

It is assumed that TPE will only be operated and maintained by trained personnel.



# Industrial furnaces and associated processing equipment — Safety —

## Part 2: Combustion and fuel handling systems

### 1 Scope

This part of ISO 13577 specifies the safety requirements for combustion and fuel handling systems that are part of industrial furnaces and associated processing equipment (TPE).

NOTE The general safety requirements common to TPE are provided in ISO 13577-1 (See introduction).

This part of ISO 13577 deals with significant hazards, hazardous situations and events relevant to combustion and fuel handling systems as listed in [Annex A](#), when used as intended and under the conditions foreseen by the manufacturer.

This part of ISO 13577 covers:

- fuel pipework downstream of and including the manual isolating valve;
- combustion air supply (including oxygen and oxygen enriched combustion air) and flue gas system;
- burner(s), burner system and ignition device;
- functional requirements for safety related control system.

This part of ISO 13577 applies to any oxidation with air or other gases containing free oxygen of gaseous and liquid fuels or any combustion of them to release thermal energy in TPE.

For thermal or catalytic post combustion and waste incineration, this part of ISO 13577 applies only to auxiliary burners designed to start-up and/or support the process.

The pressure hazard of the piping and components covered by this part of ISO 13577 is within the maximum pressure/size relationship of category I as described in normative [Annex E](#).

This part of ISO 13577 also gives the necessary requirements regarding information for use.

This part of ISO 13577 does not cover hazards from heating generated by electricity.

This part of ISO 13577 does not deal with the hazards created by the release of flammable substances from the products processed in the TPE.

This part of ISO 13577 is not applicable to combustion and fuel handling systems:

- of welding machines;
- up-stream of the TPE manual isolating valve.

This part of ISO 13577 is not applicable to electrical cabling and power cabling upstream of the TPE control panel/protective system.

## ISO 13577-2:2014(E)

## 2 Normative references

The following documents, in whole or in part, are normatively referenced in this document and are indispensable for its application. For dated references, only the edition cited applies. For undated references, the latest edition of the referenced document (including any amendments) applies.

ISO 7-1:1994, *Pipe threads where pressure-tight joints are made on the threads — Part 1: Dimensions, tolerances and designation*

ISO 49:1994, *Malleable cast iron fittings threaded to ISO 7-1*

ISO 228-1:2000, *Pipe threads where pressure-tight joints are not made on the threads — Part 1: Dimensions, tolerances and designation*

ISO 5817:2003, *Welding — Fusion-welded joints in steel, nickel, titanium and their alloys (beam welding excluded) — Quality levels for imperfections*

ISO 7005-1:2011, *Pipe flanges — Part 1: Steel flanges for industrial and general service piping systems*

ISO 7005-2:1988, *Metallic flanges — Part 2: Cast iron flanges*

ISO 7005-3:1988, *Metallic flanges — Part 3: Copper alloy and composite flanges*

ISO 8434-1:2007, *Metallic tube connections for fluid power and general use — Part 1: 24° cone connectors*

ISO 8434-2:2007, *Metallic tube connections for fluid power and general use — Part 2: 37° flared connectors*

ISO 8434-3:2005, *Metallic tube connections for fluid power and general use — Part 3: O-ring face seal connectors*

ISO 12100:2010, *Safety of machinery — General principles for design — Risk assessment and risk reduction*

ISO 13574, *Industrial furnaces and associated processing equipment — Vocabulary*

ISO 13577-1, *Industrial furnaces and associated processing equipment — Safety — Part 1: General requirements*

ISO 13577-4, *Industrial furnace and associated processing equipment — Safety — Part 4: Protective systems*

ISO 19879:2010, *Metallic tube connections for fluid power and general use — Test methods for hydraulic fluid power connections*

ISO 23551-1:2012, *Safety and control devices for gas burners and gas-burning appliances — Particular requirements — Part 1: Automatic and semi-automatic valves*

ISO 23551-2:2006, *Safety and control devices for gas burners and gas-burning appliances — Particular requirements — Part 2: Pressure regulators*

ISO 23551-3:2005, *Safety and control devices for gas burners and gas-burning appliances — Particular requirements — Part 3: Gas/air ratio controls, pneumatic type*

ISO 23552-1:2007, *Safety and control devices for gas and/or oil burners and gas and/or oil appliances — Particular requirements — Part 1: Fuel/air ratio controls, electronic type*

ISO 23553-1:2007, *Safety and control devices for oil burners and oil-burning appliances — Particular requirements — Part 1: Shut-off devices for oil burners*

IEC 60204-1:2005, *Safety of machinery — Electrical equipment of machines — Part 1: General requirements*

IEC 60730-2-5:2009, *Automatic electrical controls for household and similar use — Part 2-5: Particular requirements for automatic electrical burner control systems*

IEC 60730-2-6:2007, *Automatic electrical controls for household and similar use — Part 2-6: Particular requirements for automatic electrical pressure sensing controls including mechanical requirements*

### 3 Terms and definitions

For the purposes of this document, the terms and definitions given in ISO 13574 apply.

## 4 Safety requirements, measures and verification means

### 4.1 General

The safety goals of this part of ISO 13577 shall include:

- choice of materials such that the construction and operation of the system are not detrimentally affected. In particular, all the components of the fuel pipework shall be capable of withstanding the mechanical, chemical and thermal loads to which they can be subjected during normal operation and foreseeable abnormal operation (e.g. identified during a safety assessment);
- reliable and correct time for ignition of the air/fuel-mixture at the burner(s);
- prevention of unintentional release of unburned fuels;
- shut-off fuel-supply in case of relevant fault;
- protection of pipeline to preclude the propagation of flame in reverse direction;
- prevent firing when the evacuation of flue gas/combustion products is not ensured;
- prevent firing when the process conditions are not in the safe state.

Electrical circuits shall be designed in accordance with IEC 60204-1.

A risk assessment according to ISO 12100 shall be carried out. Safety function shall be designed in accordance with ISO 13577-4, where the use of standards for functional safety IEC 62061, ISO 13849 (all parts), IEC 61511 (all parts) and IEC 61508 (all parts) is included. Informative [Annex F](#) provides information for the determination of the SIL or PL of safety-related functions covered in this part of ISO 13577.

Specific regional requirements are given in [Annex G](#), [Annex H](#) and [Annex I](#). The safety requirements of these annexes shall ensure at least the equivalent level of safety to the requirements given in this part of ISO 13577.

### 4.2 Gaseous fuels

#### 4.2.1 Gas pipework

##### 4.2.1.1 General

The pipework design shall take into account the composition and properties (e.g. pressure, temperature, corrosiveness, specific gravity) of the fuel gas and the need for venting, purging and cleaning.

The pipework material shall comply with the relevant standards.

Due to durability, steel is the preferred material for pipes and components but where appropriate and the same safety levels can be achieved then other materials may be utilized. Such materials and conditions of service shall be specified in the instruction handbook. Oscillations which may cause damage to pipework, components or safety systems shall be prevented (by firm anchoring and/or use of flexible couplings).

**ISO 13577-2:2014(E)****4.2.1.2 Connections**

Gas pipework connections shall be metallic and shall be of threaded, compression, flanged, welded or brazed types. The number of connections shall be kept to a minimum.

Threaded connections shall be used only for the following pressure/diameter combinations:

- pressures up to 15 kPa, and diameters up to DN 100
- pressures up to 200 kPa, and diameters up to DN 50
- pressures up to 500 kPa, and diameters up to DN 25
- pressures up to 1 MPa, and diameters up to DN 15

For fittings according to ISO 49, the following limitations shall be observed:

- fittings must be class “A”;
- maximum allowed pressure is 50 kPa;
- for dimensions DN 25 or less, the maximum pressure is 500 kPa.

Where the equipment has a threaded connection, this thread shall comply with ISO 228-1 or ISO 7-1 as appropriate. The use of threads complying with ISO 228-1 is limited to diameter up to DN 50. In case of threads according to ISO 228-1, the tightness shall be ensured by a ring gasket. In case of threads according to ISO 7-1 suitable sealants shall be used to ensure tightness. Hemp shall not be used in threaded connections unless reinforced with a suitable sealant.

Other threaded connections may only be used providing they ensure tight connections and are suitably identified.

The design of pipework shall be such as to avoid tensile loading of the joints.

Compression fittings shall comply with ISO 8434-1, ISO 8434-2 and ISO 8434-3 or ISO 19879. They shall only be used for pressures up to 500 kPa and diameters up to 42 mm.

Any pipe passing through an unventilated space shall not have a connection except welded joints.

Flanges shall comply with ISO 7005-1 and ISO 7005-2 as appropriate.

Arc welding shall comply with ISO 5817, quality level C.

**4.2.1.3 Unconnected pipework**

Any unconnected pipework shall be plugged, capped or blank flanged by means of metallic parts.

**4.2.1.4 Galvanic cells**

The formation of galvanic cells shall be avoided by suitable choice of materials.

**4.2.1.5 Flexible tubing and couplings**

Flexible tubing shall comply with the general requirements of [4.2.1.1](#), together with the following:

- shall be as short as practicable;
- shall be suitable for the maximum and minimum working (fuel and ambient) temperatures;
- shall be suitable for a pressure 1,5 times the working operating pressure (with a minimum of 15 kPa), at the maximum and minimum working temperatures;
- shall have a directly accessible, upstream manual shut-off valve;

- shall be mounted in such a way as to avoid distortion, whiplash and damage;
- shall have end fittings as integral parts of the tubing;
- shall be constructed from suitable material both metallic and/or non-metallic selected for the application duty and not be easily damaged.

Couplings for removable equipment shall ensure a gastight connection with the equipment connected and disconnected.

#### 4.2.1.6 Marking

The pipework shall be identified as gas pipework.

NOTE Identification of gas pipework is dealt with by national regulations.

#### 4.2.1.7 Soundness/tightness

The gas pipework shall be tight and shall be designed to withstand the internal pressure. After assembly, the gas pipework shall be submitted to its test pressure and tested for tightness. The test pressure shall be not less than 1,1 times the maximum working pressure at any point with a minimum of 5 kPa.

The external leakage rate shall not give rise to a dangerous condition, flammable and/or toxic, in the foreseen circumstances of the equipment installation. The frequency of testing to determine the external leakage shall be specified in the instruction handbook.

NOTE It is generally agreed that an external leak rate of  $\approx 1 \text{ dm}^3(\text{n})/\text{h}$  will not give rise to a dangerous condition in typical ventilated industrial installations. The actual leak rate will depend upon the volume, number of connections, test gas, number of valves and component parts contained.

The external leak rate test method shall take into account the volume, number of connections, test gas, number of valves and component parts contained and temperature. Methods of testing shall include spray bubble leak identification and/or pressure decay test.

#### 4.2.1.8 Condensate drains

In cases where condensates can create a hazard, means shall be provided at the lowest points of the equipment for draining any condensate. When moist gases are being used, condensate drains of a suitable type shall be installed. Any condensate drains, siphons, etc. shall be in a position such that they can be easily checked. Flammable condensates shall be collected by an appropriate means (e.g. piped into a container).

Valves in condensate drains shall be suitably plugged, capped or blank flanged by metallic parts.

#### 4.2.1.9 Purge points

Means shall be provided to facilitate purging of the gas system during commissioning and maintenance to prevent the build-up of flammable substances.

#### 4.2.1.10 Blow-off and breather pipes or conduits

Where blow-off or breather pipes or conduits are fitted on regulators or relief valves or vent valves, adequate means shall be provided to facilitate the venting of gas from the system to a safe discharge area.

In case breathers or blow-off pipes are gathered, the cross section of the collector shall be suitable to evacuate simultaneously total flow rates of the exhaust sources.

In case breathers are gathered with blow-off pipes, non-interaction of the collected lines, valves and instruments shall be verified.

## ISO 13577-2:2014(E)

**4.2.1.11 Pressure relief devices and flame arrestors on pipework**

For equipment designed for situations in which flashback can occur, flame arrestors and/or pressure relief devices shall be fitted.

Pressure relief devices shall be designed to yield at a pressure below the design pressure of the pipework and shall be positioned such that the discharge flow and the pressure relief device does not constitute a risk to the equipment, personnel or third parties.

A flashback at least shall trigger an alarm. The required measures after a flashback shall be described in the instruction handbook.

**4.2.1.12 Pressure oscillations**

The gas pipework shall be designed so as to avoid the possibility of gas velocities and pressure fluctuations causing oscillations which could cause damage to pipework, components or safety systems (e.g. by designing the correct sizing of pipe, using pressure regulator).

**4.2.1.13 Equipment supplied with different fuel gases**

Where a burner is intended for alternating use with more than one gaseous fuel, means shall be provided to ensure that the supply pipework of the gas not being fired is positively isolated.

**4.2.1.14 By-pass**

By-passes shall not be fitted in parallel with any item of safety equipment.

This requirement shall not apply to valve proving systems (see ISO 23551-4) on automatic shut-off valves.

**4.2.1.15 Isolation of required safety devices**

Required safety devices (e.g. pressure switches, relief valves) shall not be isolated from the equipment they protect during start-up or operation of the burner. In case isolating valves cannot be avoided and are mounted between these required devices and the main lines, these isolating valves shall be locked in the open position during operation of the equipment by adequate means (e.g. manual lock).

**4.2.2 Required safety devices****4.2.2.1 Manual isolating valve**

A manually operated isolation valve shall be fitted upstream of the first control device in the gas circuit. Manual isolation valves shall be so designed or positioned as to prevent inadvertent operation but shall be easily accessible and capable of rapid operation when required.

They shall be so designed that the "OPEN" and "CLOSED" positions are readily distinguishable (e.g. a 90° turn valve if applicable and available).

**4.2.2.2 Filter/strainer**

Special care shall be taken to prevent the ingress of particles, either from the pipework or from the gas, which would be detrimental to the operation of the equipment by the incorporation of a suitable filter or strainer immediately downstream of the first manual isolating valve of the TPE. Additional filters/strainers may be required (e.g. immediately upstream of the automatic shut-off valve). The filter and/or the strainer shall be positioned in such a way that periodic servicing remains easy. The filtering capacity of the filter/strainer has to be chosen according to the requirements of downstream equipment.

NOTE Normally safety and control devices for gas burners and gas-burning appliances require upstream filters with filtering capacity  $\leq 50 \mu\text{m}$ . Strainers with larger mesh size are only suitable for primary cleaning.

In case of the installation of a by-pass to the filter/strainer, an identical filtering device shall be installed on the by-pass line.

The intervals for checking the filter and/or the strainer shall be specified in the instruction handbook.

#### 4.2.2.3 Gas pressure regulator

A gas pressure regulator shall be incorporated where this is necessary for control of the pressure and the flow rate.

Gas pressure regulators when fitted shall comply with ISO 23551-2 as appropriate.

If the outlet side of the gas pressure regulator and/or the following line section with equipment up to the burner is/are not designed for the maximum supply pressure (inlet pressure upstream to the gas pressure regulator under fault conditions) an over pressure cut-off device shall be installed upstream of the gas pressure regulator shutting off the gas supply before an excessively high pressure occurs.

The over pressure cut-off device shall be:

- a mechanical valve which measures the gas pressure downstream of the gas pressure regulator by means of an impulse line and closes by spring force in case the pressure exceeds the set response pressure, or
- an automatic shut-off valve according to ISO 23551-1 actuated by an overpressure detector installed downstream of the gas pressure regulator. The overpressure detector shall comply with IEC 60730-2-6 or be evaluated to ensure appropriate reaction time and accuracy. In this case, signal processing has to fulfil the requirements of a protective system according to ISO 13577-4.

A small capacity relief valve (token relief valve) shall always be applied downstream of the gas pressure regulator, if an over pressure cut-off device is installed to vent small leakages of the high pressure cut-off.

Pressure adjustment on the gas pressure regulator shall only be possible with a special tool provided for the task.

Where the gas for the pilot burner is taken from upstream of the gas pressure regulator to the main burner(s), the pilot burner shall be equipped with a separate gas pressure regulator.

#### 4.2.2.4 Low gas protection

Low gas pressure protection shall be fitted. The low gas pressure protection device has to provide satisfactory and reliable proof of the pressure for all operation conditions.

The system shall prevent start-up or cause safety shut-down and lock-out in the event of pressure falling below a pre-determined value. This function shall meet a requirement of the protective system according to ISO 13577-4.

Gas pressure detectors shall comply with IEC 60730-2-6 or shall be evaluated to ensure appropriate reaction time and accuracy.

#### 4.2.2.5 High gas protection

High gas pressure protection shall be fitted in all circumstances except when:

- the equipment supply pressure does not exceed 10 kPa, and
- regulator failure does not result in an unsafe start-gas rate being obtained.

Where high gas pressure protection is required, the system shall prevent start-up or cause safety shut-down and lock-out in the event of a pre-determined pressure being exceeded. This function shall meet the requirements of a protective system according to ISO 13577-4.

**ISO 13577-2:2014(E)**

Gas pressure detectors shall comply with IEC 60730-2-6 or shall be evaluated to ensure appropriate reaction time and accuracy.

**4.2.2.6 Automatic shut-off valves**

The gas supply to each burner or group of burners shall be under the control of two automatic shut-off valves in series in the gas pipework in accordance with the following subclauses of ISO 23551-1:2012:

- for general requirements: subclause 7.1;
- for leak tightness: subclause 7.2;
- for durability: subclause 7.5;
- for the closing function: subclause 7.6.101;
- for the closing force: subclause 7.6.104;
- for the closing time: subclause 7.6.106.

The sealing force for automatic shut-off valves shall be equal to or greater than 15 kPa.

For natural draught burner with a controlled capacity below 70 kW the sealing force for automatic shut-off valves shall be at least 5 kPa.

The automatic shut-off valve shall endure the intended number of cycles in the TPE.

Valves construction and materials shall be suitable for the used gas composition.

Automatic shut-off valve shall be capable of withstanding all upstream pressures, backpressure and differential pressure under all process circumstances.

High cycling applications over 100 000 cycles/year, (e.g. pulse firing, regenerative burners) shall use only valves that are declared capable of the intended number of cycles and on/off cycling rate.

The instruction handbook shall specify the need to check automatic shut-off valves for correct operation, the procedure to be adopted and the intervals at which this should be carried out and the requirements for replacement. Means to permit the operator to determine when automatic shut-off valves require replacement shall be supplied.

**NOTE** It is commonly agreed that valves are to be tested annually unless longer testing intervals can be justified by the risk analysis.

All systems shall have the ability for manual leak testing of the automatic shut-off valve.

Control valves may be used as safety shut-off valves provided they are designed as both safety shut-off and modulation valves and tested for concurrent use.

The automatic shut-off valves shall not open or shall shut off the fuel to the burner when the limit of any safety condition is reached. In this case, the relevant automatic shut-off valves shall be de-energised by a protective system according to ISO 13577-4.

**NOTE** Examples for safety related conditions to be considered are (but not limited to): minimum and/or maximum gas flow, minimum and/or maximum gas pressure, minimum and/or maximum air flow, minimum and/or maximum air pressure, failure of power supply and/or other utilities (e.g. compressed air, steam), failure of heat transfer fluid, fume extraction malfunction, minimum and/or maximum operation temperature, minimum and/or maximum combustion chamber pressure, flame failure, failure of valve proving as referred in [4.2.2.7](#), incorrect air gas ratio as referred in [4.3.3.3](#).

It shall only be possible to manually reset (locally or remotely) the lock out of a closed automatic shut-off valve.

Flame failure or process control shut down shall cause the closing of two automatic shut-off valves piped in series except in the following cases where closing a single individual burner shut off valve is sufficient:

- in case of high-temperature equipment;
- in case of low-temperature equipment where the individual burner automatic shut-off valve is fitted with proof of closure according to ISO 23551-1, and the protective system closes an upstream automatic shut-off valve (header valve) if one of the individual burner valve is not proven closed by the prove of closure switch.

Flame failure or process control shut down of radiant tube burner system shall cause the closing of two automatic shut-off valves piped in series except in the following cases where the closing of a single individual burner shut off valve is sufficient:

- each radiant tube burner system is explosion resistance and the exhaust system dilutes the ignitable fuel-air-mixture from leaking gas valves inside the exhaust system below 25 % of the LFL.

For typical examples of piping and components see informative [Annex C](#).

#### 4.2.2.7 Valve proving

Automatic shut-off valves controlling capacities higher than 1 200 kW shall be proved closed at each start-up of the TPE. In case where the valve is not proved closed, the current start-up shall be stopped and the system shall go to lock-out. The valve proving procedure and the action after such failure shall be specified in the instruction handbook (e.g. replacement of valve).

NOTE It is generally agreed that a leak rate of the valve(s) below 0,1 % of the maximum gas flow into the combustion chamber during operation is considered as proved close valve. In case of preheated gas and/or oxygen or oxygen enriched combustion this value has to be readjusted accordingly.

For a TPE intended to be started up more than two times a year, the automatic shut-off valve(s) shall be proved closed by an automatic system.

Automatic valve proving shall fulfil the requirements of a protective system according to ISO 13577-4.

In multiple burner systems with two automatic shut-off valves for each burner, automatic testing does not have to prove each burner valve individually (see [Figure C2b](#)). The testing of the individual burner valves shall be specified in the instruction handbook.

#### 4.2.2.8 Individual manual shut-off valves for burners

For burners which are independently ignited, each individual burner shall be fitted with a manual shut-off valve suitable for the type of gas.

However, if the installation of such a manual valve affects the mixing characteristics of mixing devices (e.g. venturi mixers), then the shut-off valve shall be installed upstream of any such device.

For multiple burners in which cross-ignition from burner to burner occurs by design, the complete group of burners shall be fitted with at least one manual shut-off valve.

### 4.2.3 Combustion air and air/fuel ratio

#### 4.2.3.1 Combustion air system

The pipework design shall take into account the properties of combustion air (e.g. pressure, temperature).

The location of the combustion air intake shall be such as to prevent entry of impurities (e.g. dust) and flue products, unless provided for by the design (e.g. for reduction of emission of nitrogen oxides NO<sub>x</sub>).

The ventilation of TPE shall be such as to allow an adequate supply of process air and combustion air to reach the burner(s) under all conditions.

**ISO 13577-2:2014(E)**

Attention should be paid to sufficient air supply to the TPE. For many applications, it is recommended to install an air inlet filter with filter monitoring to achieve reliable operation of the installation.

The combustion air system shall be designed in a manner that prevents the back-flow of furnace atmosphere through combustion equipment.

The air circuit shall be designed so as to avoid oscillations that may lead to material defects.

**4.2.3.2 Air flow and pressure detectors**

TPE fitted with forced or induced draught burner(s) shall be fitted with devices for proving adequate air flow during ignition and operation of the burner.

Air flow failure at any time during the pre-purge, ignition or operation of the burner shall cause safety shut-down and shall cause a lockout. This function shall meet the requirements of a protective system according to ISO 13577-4.

The air-proving device shall be checked in the “no flow” state prior to start-up [e.g. by stopping the combustion air supply or by interrupting the air signal to the device(s) in such a way as to simulate stopping the combustion air supply]. Failure to prove the device in the “no flow” condition shall prevent start-up.

Air flow shall be monitored:

- by pressure detectors or
- by flow detectors.

It shall be shown that any of these devices provide satisfactory and reliable proof of the flow for all operating conditions.

This requirement shall not apply to portable gas burners, work station burners and equipment-integrated burners with open flame, supervised continuously by trained operators, and having a maximum burner input rating below 70 kW.

Air pressure detectors shall comply with IEC 60730-2-6 or shall be evaluated to ensure appropriate reaction time and accuracy. They shall be suitable for the number of operations foreseeable for the application.

**4.2.3.3 Air/fuel ratio**

The air mass flow shall always be in a ratio with the gas mass flow in order to ensure safe ignition and that throughout the operating range, a stable and safe combustion is maintained at each individual burner. The ratio does not need to be the same value at all operational conditions.

If the variation of pressure and/or temperature of air and fuel gas affect the safety and combustion stability, then correction for pressure and/or temperature is required.

The design of the air/gas ratio control has to consider process conditions as well as fuel and combustion air properties. Defect or malfunction should effect that the system will tend towards higher excess air or proceed to lockout if the air/gas ratio results in an unsafe condition.

Pneumatic gas/air ratio controls shall comply with ISO 23551-3, if applicable.

Electronic gas/air ratio controls shall comply with ISO 23552-1, if applicable.

To ensure their reliability, air/gas ratio controllers according to ISO 23551-3 or ISO 23552-1 shall be used in conditions (temperature, pressure, flow rate) for which they have been designed. These conditions and instructions for maintenance shall be specified in the instruction handbook.

In case other methods/technologies are used for the ratio control and depending on the combustion air and fuel gas properties, additional protective measures shall be applied according to the results

of the risk assessment (e.g. air/fuel ratio monitoring by protective system according to ISO 13577-4). The method/technology and the procedure for the functional test shall be described in the instruction handbook.

#### **4.2.4 Supply of pre-mixed fuel gas/air**

##### **4.2.4.1 Mixture pipework**

The mixture pipework volume shall be minimized to reduce risk in the event of flashback, but shall not compromise pressure and flow distribution needed for stable burner operation. The system shall be designed so as to provide a sufficiently high mixture flow velocity such that flame propagation upstream cannot occur, or shall be fitted with flame trap(s)/arrestor(s), pressure relief devices or blowout devices to prevent damage in the mixture pipework and mixing equipment.

Flame trap(s)/arrestor(s) if used shall be located as close to the burner(s) as practicable.

Alternatively, the system shall be fitted with a sensor which causes lock-out in the event of the flow velocity falling below a pre-determined limit or a temperature sensor which causes lock-out in the event of flashback. This function shall meet the requirements of a protective system according to ISO 13577-4. These devices are not required for burners where the manufacturer can demonstrate that flashback cannot occur in any circumstances (e.g. pilot burners with their own mixing devices).

##### **4.2.4.2 Air and gas supply to the mixture circuit**

The presence of fuel gas/air mixture in the pipework supplying either fuel gas or air to the mixing device (e.g. due to reverse flow of the mixture) shall be prevented.

If a non-return valve is used for this purpose and if it is not resistant to flashback, then an additional high gas pressure switch located downstream of this non-return valve shall be incorporated to shut off the flow of fuel gas to the equipment by means of the relevant automatic shut-off valves specified in [4.2.2.6](#) in the event of a flame flashback.

A flashback shall trigger an alarm. The required measures after a flashback shall be described in the instruction handbook.

#### **4.2.5 Burners**

##### **4.2.5.1 Main burners**

All burners shall be suitable for the working conditions and shall provide operating safety for:

- the fuels used (type, pressure, etc.);
- the operating conditions (pressure, temperature, atmosphere, etc.);
- the nominal input rate and range of regulation (maximum and minimum capacity);
- ease of visual monitoring (sight glasses, sight holes, etc.).

##### **4.2.5.2 Radiant tube burner systems**

Radiant tube burner systems shall be suitable and allow safe operation. They shall:

- be constructed of suitable materials for the thermal input rate, temperature and furnace atmosphere;
- minimize the probability of combustion products having contact with the furnace atmosphere.

## ISO 13577-2:2014(E)

#### 4.2.5.3 Ignition device/pilot burner

The ignition device shall be reliable and of sufficient capacity, so that immediate, low noise and smooth ignition is obtained. Detail verification procedure for use in commissioning, operation and maintenance shall be included in the instruction handbook.

Any direct ignition device or combination of the ignition device and the pilot burner in automatic installations shall form an integral part of the main burner system.

The construction and location of a pilot burner shall be such that, under all operating conditions, the pilot flame remains stable and of such a shape that the main flame is ignited.

For safety requirements, pilot burner(s) shall be treated as main burners and [4.2.2.3](#), [4.2.2.4](#), [4.2.2.5](#), [4.2.2.6](#), [4.2.2.7](#), [4.2.2.8](#), [4.2.3.2](#), [4.2.3.3](#), [4.2.6](#) and [4.2.7](#) shall apply.

Where pilot burners are used in the case of main burners supplied with gas or combustible vapours with uncertain combustion characteristics, e.g. varying calorific value, permanent pilots shall be independently supplied with a clean fuel gas of constant quality (e.g. natural gas, liquefied petroleum gas) and be fitted with automatic burner control systems according to [4.2.6](#).

Where use is made of a portable pilot burner or ignition device:

- the pilot burner or ignition device shall be capable of being fitted in one way only and in such a way that it occupies a fixed position with respect to the burner to be ignited — if necessary the correct position shall be monitored;
- the connections for fuel, air and ignition energy shall be so designed that a reliable link-up is obtained, and errors of fitting of connections are avoided.

#### 4.2.5.4 Burner capacity control

In any combustion system, the turndown ratio shall be such that the burner(s) is/are fully stable at all firing conditions. Means shall be provided to allow the determination of the burner capacity.

#### 4.2.5.5 Flue gas venting

Flue gases shall be vented in a safe way.

TPE with a closed combustion chamber or combustion chamber with at least three surrounding walls shall be equipped with a flue system. The cross sectional area of the flue system shall be calculated according to volume, pressure and temperature of the flue gases (products of combustion, excess air and process emissions).

For TPE's equipped with natural draught burners the flue system shall be fitted with an appropriate draught break above the height of the operator, or control damper (for typical example of a draft break see [Figure C.7](#)).

If the flue gases are extracted by a fan or the draught is controlled by a damper and the risk is not adequately reduced by the inherently safe design or mechanical design, the system shall be fitted with a safety device to cause a safety shut down of the burner(s) or a switching over to a backup duct system in the event of a failure in the flue venting. This function shall meet the requirements of a protective system according to ISO 13577-4.

For all TPE equipment burners supplied without a flue system, the combustion products shall be directed away from the workplace. The instruction handbook shall refer to the need for sufficient venting to ensure the correct air quality for the operator.

NOTE EN 525 gives useful information on maintaining the air quality in workshops.

## 4.2.6 Automatic burner control systems

### 4.2.6.1 General

The main flame and, if applicable, the pilot burner flame, shall be supervised by means of an automatic burner control system or a flame detector complying with IEC 60730-2-5. Exceptions are only permitted when specified in this part of ISO 13577 (e.g. see [4.2.6.3](#) and [4.2.6.4](#)). Flame supervision and burner control function shall meet the requirements of a protective system according to ISO 13577-4.

For systems where the pilot burner remains in use during main burner operation, separate flame detector device to supervise the pilot and main flames shall be fitted. The main flame detector device shall be so positioned that it cannot in any circumstances detect the pilot flame.

Where the pilot burner and the main burner are each provided with their own flame detector device, the pilot flame shall not influence the response of the main flame sensor.

A single flame detector device shall be sufficient:

- for systems where the pilot flame is extinguished during main burner operation;
- for any metallic fuel fired radiant tubes, explosion resistant and equipped with a burner fitted with permanent pilot burner.

Where fitted, flame sensors shall be unresponsive to unintended radiation.

Where a burner is required to fire continuously for periods in excess of 24 h, the automatic burner control system shall be designed for permanent operation as described in IEC 60730-2-5.

The detection of a flame when there should not be a flame or a defect of the automatic burner control system or the protective system shall result into lock-out.

### 4.2.6.2 Low-temperature equipment

Low-temperature equipment fitted with a single burner shall be equipped with an automatic burner control system in accordance with [4.2.6.1](#).

For low-temperature multiple burner equipment, each burner shall be equipped with an automatic burner control system.

Only one of the burners in multiple burner equipment may be equipped with an automatic burner control system operating continuously provided that the burners guarantee stable combustion throughout the range of regulation, are on the same air/gas ratio control system and are arranged adjacent and in such a way that, if one of them is extinguished, it is re-ignited quickly and smoothly by the flame from the next burner. This shall not apply to burners controlled by “on/off” systems.

### 4.2.6.3 High-temperature equipment

During high-temperature operation, the temperature shall be monitored. In the event the temperature falls below the limit, the control system shall automatically shut off the gas supply or shall switch over to flame supervision by means of an automatic burner control system according to [4.2.6.1](#). This function shall meet the requirements of a protective system according to ISO 13577-4.

The temperature limit for high-temperature operation shall not be less than 750 °C and the temperature shall be detected at the coldest point.

**NOTE** At radiant tube burner systems the ignition point is inside the radiant tube. The temperature inside the tube and prior to ignition may well be much lower than in the chamber in which the radiant tube is placed. This temperature difference has to be taken into consideration when designing.

During start-up period, flame supervision, either by means of an automatic burner control system or by the operator, shall be provided when the combustion chamber wall temperature is below the

**ISO 13577-2:2014(E)**

temperature limit for high-temperature operation. For TPE intended to be started more than 4 times a year, flame supervision below 750 °C shall be by means of an automatic burner control system. Additional burners that operate during high-temperature operation without flame supervision shall be isolated from the fuel gas supply by two automatic shut-off valves until the temperature is above the limit for high-temperature operation. This function shall meet the requirements of a protective system according to ISO 13577-4.

The high-temperature operation, the method/procedure for flame supervision during start-up period and switch over to high-temperature shall be described in the instruction handbook.

**4.2.6.4 Automatic burner control systems for burners operating in the open air**

Each burner firing in the open air (i.e. no combustion chamber) with a rated heat input greater than 70 kW shall be fitted with an automatic burner control system.

Where the burner heat input rating is 70 kW or less, the flame may be supervised by the operator, provided that the flame is always visible to the operator at his/her workstation.

If the flame cannot be observed continuously from the workplace, an automatic burner control system shall be provided.

Where an installation is equipped with several burners other than ON/OFF burners, no automatic burner control system is required if the burners are arranged in a configuration in which the flame of an operating burner will reliably crosslight another burner in the event of flame extinction. However, in this case at least one burner shall be equipped with spark restoration or a supervised permanent pilot designed so that a failure of the permanent pilot or the spark restoration system leads to safety shut-down of all the burners.

If necessary for process reasons (e.g. load damaged due to lock-out), and where the single burner capacity is below 100 kW, the lock-out function integrated into a multiple burner installation may be replaced by an acoustic and a visual alarm providing the operator can react in a time to be specified in the instruction handbook.

**4.2.7 Start-up of the heating system and burner ignition****4.2.7.1 Pre-purging of the combustion chamber**

Except when specified below, start-up of the TPE or re-start of the TPE after a lock-out shall not be initiated until adequate steps have been taken to ensure that no combustible mixture is present in the combustion/processing chamber, connected spaces and flue system (heat exchangers, dust extractors). This condition shall be achieved by means of a period of pre-purging immediately prior to ignition or within a time to be specified in the instruction handbook.

The pre-purge time shall be such as to ensure that the concentration of any combustible products in any part of the combustion chamber/connected spaces and flue system is below 25 % of the lower flammability limit (LFL) of the fuel gas; this being calculated with the combustion chamber/connected spaces and the flue duct assumed as being initially filled up with flammable gases.

In general, five complete air changes of the combustion chamber/connected spaces and flue system will suffice. The air flow rate used for a pre-purge shall be at least 50 % of the maximum combustion air flow rate. In the case of natural draught, the condition to achieve the above requirements shall be defined in the instruction handbook.

The pre-purge time and purge procedure and/or methodology shall be specified in the instruction handbook.

The system for ensuring correct pre-purge time and the airflow shall meet the requirements of a protective system according to ISO 13577-4.

When the combustion chamber is proved to be at a temperature above 750 °C (as defined for high-temperature equipment) pre-purge may be omitted.

Inert or non-flammable gases shall be used instead of air if required by the equipment or process. Other methods of ensuring that the combustion chamber and connected spaces do not contain flammable gases may be utilized providing that the equivalent level of safety is achieved.

In multiple burner equipment a single burner may be re-started without pre-purge in the following cases:

- when restarting a burner after shut-down for control purpose where the burner is fitted with an independently supervised permanent or alternating pilot;
- when one or more burners remain alight in the same combustion chamber of the burner to be re-ignited and the burner(s) remaining in operation shall provide ignition of any unintended release of fuel through other burners that are not in operation without causing a hazard (e.g. deflagration);
- where the burner is fitted with two automatic shut-off valves that close simultaneously and a valve proving according to [4.2.2.7](#) is conducted before each burner start;
- with pulse fired burners, equipped with two automatic shut-off valves that close simultaneously and provided the automatic shut-off valves are declared to be suitable for the intended number of cycles and on/off cycling rate by the manufacturer of the automatic shut-off valve — it shall be ensured, that at least once per hour at least one burner per zone is burning for at least 10 s to provide ignition of any unintended release of fuel without causing a hazard (e.g. deflagration);
- with regenerative burners equipped with two automatic shut-off valves that close simultaneously and provided the automatic shut-off valves are declared to be suitable for the intended number of cycles and on/off cycling rate by the manufacturer of the automatic shut-off valve;
- when restarting a radiant tube burner after shut-down for control purpose provided the radiant tube is resistant to explosion and the burner is equipped with two automatic shut-off valves that close simultaneously and that the radiant tube burner is equipped with an ignition device according to [4.2.5.3](#).

In the case of a flame failure of one burner out of a group of radiant tube burners, maximum of one re-start without pre-purge is permitted before lock-out after a flame failure, if:

- each burner has an automatic burner control system according to [4.2.6](#), and
- the exhaust system dilutes the ignitable fuel-air-mixture inside the exhaust system below 25 % of the LFL or the radiant tube, the burner and the connection to the exhaust are designed for the maximum pressure increase that is possible during ignition, and
- the gas supply to each radiant tube burner is equipped with automatic shut-off valve according to [4.2.2.6](#).

#### 4.2.7.2 Start-up of the fuel supply

Start-up of the fuel supply shall be possible only when:

- the installed air and fuel gas proving devices (e.g. air flow, gas pressure) have been checked to ensure that they are in the correct operating condition for start-up, and
- all relevant interlocks (e.g. burner(s) position, valve(s) position, flue damper(s)) have been proved to be in the correct position.

#### 4.2.7.3 Start fuel flow rate

The energy released during the start-up of the burner(s) shall be limited so that the maximum pressure rise from ignition shall not cause any damage to the TPE (see [Table 1](#), [Table 2](#) and [Table 3](#)).

## ISO 13577-2:2014(E)

The start fuel flow rate shall be controlled by control and/or a protective system according to ISO 13577-4 based on the outcome of the risk assessment.

Where the burner is ignited manually (e.g. by means of a lighting torch) and has a burner input rate in excess of 70 kW, it shall be equipped with a means of limiting the start-up gas flow.

#### 4.2.7.4 Ignition

The ignition process shall be initiated immediately after the conclusion of the pre-purging stage or within a time to be specified in the instruction handbook.

Where the main burner is ignited by means of a pilot burner, the gas supply to the main burner shall be shut off during the pre-purge and ignition of the pilot burner. The automatic shut-off valve(s) of the main burner shall open only when the pilot burner flame has been proved.

NOTE Where air enriched with oxygen or oxygen alone is the oxidising agent for the combustion of a gas, (commonly called oxy/fuel firing), then the ignition procedures and times for such systems may require specific additional design attention to ensure the equivalent levels of safety.

#### 4.2.7.5 Maximum safety times for natural draught burners

The safety time and total closing time for natural draught burners shall not exceed the values given in [Table 1](#) and [Table 2](#).

**Table 1 — Maximum safety times for natural draught burners operating in open air**

Burner input rate kW	Safety time s	Total closing time s
1) Thermoelectric flame supervision device		
up to and including 70	60	45
2) Flame supervision device other than thermoelectric		
up to and including 70	10	10
above 70 up to and including 360	10	3
above 360 <sup>a</sup>	5	3
<sup>a</sup> Ignition at a rate of 33 % of the burner input rating with a maximum of 360 kW.		

**Table 2 — Maximum safety times for natural draught burners operating in combustion chamber**

Burner input rate kW	Safety time s	Total closing time s
1) Thermoelectric flame supervision device		
up to and including 2,5	60	45
2) Flame supervision device other than thermoelectric		
up to and including 70	10	10
above 70 up to and including 360	10	3
above 360 <sup>a</sup>	5	3
<sup>a</sup> Ignition at a rate of 33 % of the burner input rating with a maximum of 360 kW.		

#### 4.2.7.6 Maximum safety times for forced and induced draught burners

The maximum start gas rate and the corresponding safety time for forced and induced draught burners shall not exceed the values given in [Table 3](#).

Burner start-up shall be achieved in accordance with one of the following methods:

- direct ignition of the main burner at full rate (see [Table 3](#), Column 2) or
- direct ignition of the main burner at reduced rate e.g. by using slow opening valve; (see [Table 3](#), Column 3) or
- direct ignition of the main burner at reduced rate with by-pass start gas supply to the burner or two step automatic shut-off valve; (see [Table 3](#), Column 4) or
- ignition of the main burner by means of an independent pilot burner; (see [Table 3](#), Column 5).

For methods of burner start-up, see [Annex D](#).

**Table 3 — Maximum safety times for forced and induced draught burners**

1	2	3	4		5	
	Direct main burner ignition at full rate	Direct main burner ignition at reduced rate with slow opening valves	Direct main burner ignition at reduced rate with <b>by-pass</b> start gas supply		Main <b>burner ignition</b> with independent <b>pilot burner</b>	
					Pilot burner ignition ( $Q_{ST} \leq 0,1 \times Q_{F \max}$ )	Main burner ignition
Rate $Q_{F \max}$	Safety time $t_s$	Safety time $t_s$	Rate $Q_{ST}$	Safety time $t_s$	<b>First safety time</b> $t_{s1}$	<b>Second safety time</b> $t_{s2}$
kW	s	s	kW	s	s	s
$\leq 70$	5	5	$\leq 70$	5	5	5
$> 70$ $\leq 120$	3	3	$\leq 70$	5	5	3
			$> 70$ $\leq 120$	3		
$> 120$ $\leq 360$	not allowed except as described below	3	$\leq 70$	5	5	3 with slow opening valves or $t_s \times Q_s < 150$ (max. $t_s = 3$ s)
			$> 70$ $\leq 360$	$t_s \times Q_s < 100$ (max. $t_s = 3$ s)		
$> 360$	not allowed except as described below	not allowed except as described below	$\leq 70$	5	5 ( $Q_{ST} \leq 70$ KW)	$t_s \times Q_s < 150$ (max. $t_s = 3$ s)
			$> 70$	$t_s \times Q_s < 100$ (max. $t_s = 3$ s)	3 ( $Q_{ST} > 70$ KW)	
$Q_{F \max}$ = maximum main burner input rate in kilowatts $Q_{ST}$ = start input rate in kilowatts $Q_s$ = maximum start input rate expressed as a percentage of $Q_{F \max}$ ( $Q_s = Q_{ST}/Q_{F \max}$ ) $t_s$ = safety time in seconds						

Higher start gas rates than those specified in [Table 3](#) may be achieved at the end of the safety time provided that it is proved that the total amount of energy released in the combustion chamber during the safety time is not greater than the energy release calculated by multiplying the values of maximum start gas heat input and safety time given by [Table 3](#).

Only if required for process reasons or special cases of equipment construction and if the above mentioned ignition safety times cannot be used, the function and values of the ignition safety time may differ from those given in [Table 3](#) provided the safety of the TPE is not endangered. In any case the safety time shall not exceed 10 s.

## ISO 13577-2:2014(E)

Where for process reasons, burners with a nominal input exceeding 120 kW are ignited directly at full rate or burners with a nominal input exceeding 360 kW are ignited directly at reduced rate using slow opening valves the combustion chamber/process chamber, flue ways and pipework shall be designed to take account of the maximum pressure rise.

In the case of long cross-ignited burners, an extension of the safety time by 1,5 s/metre of burner length, with a maximum of 10 s is acceptable providing the flame is monitored at the end of the burner remote from the source of ignition and safe ignition always takes place.

### 4.2.7.7 Flame failure on start-up

In the event that flame failure occurs during the safety time, the burner shall go to lock-out. However, re-cycling is acceptable providing equipment safety is not compromised (e.g. atmosphere in the combustion chamber does not exceed 25 % of LFL). The number of re-cycles shall not exceed two. The re-cycle(s) function shall meet the requirements of a protective system according to ISO 13577-4. If there is no flame signal at the end of these re-cycles, the failing burner shall go to lock-out.

The conditions of and the time period between recycle and the number of re-cycles shall be specified in the instruction handbook.

### 4.2.7.8 Flame failure during operation

In the event of flame failure during operation the burner shall go to lock-out. However, safety shut-down and recycling are acceptable providing equipment safety is not compromised (e.g. atmosphere in the combustion chamber does not exceed 25 % of LFL). The re-cycle function shall meet the requirements of a protective system according to ISO 13577-4. If there is no a flame signal at the end of this re-cycle, the failing burner shall go to lock-out.

Not more than one re-cycle shall be permitted, the conditions for which shall be specified in the instruction handbook.

The total closing time shall not exceed 3 s. However, in cases where there is no recycle without purge and if the LFL-level in the combustion chamber does not exceed 25 %, the total closing time shall not exceed 5 s.

The TPE shall be designed such that a recycle of a single burner system requires a complete recycle including pre-purge.

## 4.3 Liquid fuels

### 4.3.1 Liquid fuel pipework

#### 4.3.1.1 General

The pipework design shall take into account the composition and properties of the liquid fuel and the need for venting, purging, cleaning, heat tracing and insulation.

The pipework material shall comply with the relevant standards.

For durability, steel is the preferred material for pipes and components but where appropriate and the same safety levels can be achieved then other materials can be utilized. Such materials and conditions of service shall be specified in the instruction handbook.

Oscillations which could cause damage to the pipework, components, safety systems shall be prevented (e.g. by firm anchoring, use of flexible coupling).

Where excessive pressure can occur in the pipework due to thermal expansion of the liquid fuel, means of pressure relief shall be provided.

#### 4.3.1.2 Connections

Liquid fuel pipework connections shall be of threaded, compression, flanged or welded types. Other types of connections, such as couplings for removable equipment, shall ensure a liquid tight connection with the equipment connected and disconnected. Threaded connections shall be used only for the following combinations:

- pressures up to 1 MPa;
- temperatures up to 130 °C;
- diameters up to DN 25.

Threaded connections may be used for higher pressures and temperatures where the connection is specifically designed to operate under those conditions without creating a risk. In this case the connection ratings for pressure and temperature shall be specified in the instruction handbook.

Compression connections shall comply with ISO 8434-1, ISO 8434-2 and ISO 8434-3 and ISO 19879 and only for the following combinations:

- pressures up to 4 MPa;
- diameters up to DN 32.

For other combinations of pressures and diameters, connections shall be by means of welded flanges or welded joints. The number of connections shall be kept to a minimum.

Where the equipment has a threaded connection, this thread shall comply with ISO 228-1 or ISO 7-1 as appropriate. In the case of parallel threads, care shall be taken to ensure an adequate seal.

Other threaded connections may only be used providing they ensure tight connections and are suitably identified.

The design of pipework shall be such as to avoid tensile loading of the joints.

Solder with a melting point below 450 °C and adhesives shall not be used.

Any pipe passing through an unventilated space shall not have a connection except welded joints.

Flanges shall comply with ISO 7005-1, ISO 7005-2 and ISO 7005-3, as appropriate.

Arc welding shall comply with ISO 5817, quality level C.

Special requirements for liquefied petroleum gas in the liquid phase shall be considered.

#### 4.3.1.3 Unconnected pipework

Any unconnected live pipework shall be plugged, capped or blank flanged by means of metallic parts.

#### 4.3.1.4 Flexible tubing and couplings

Flexible tubing shall comply with the general requirements of [4.3.1.1](#), together with the following:

- shall be as short as practical;
- shall be suitable for the maximum and minimum operating temperatures;
- shall be suitable for a pressure 1,5 times the maximum operating pressure (with a minimum of 100 kPa), at the maximum and minimum operating temperatures;
- shall have a directly accessible, upstream manual shut-off valve;
- shall be mounted in such a way as to avoid distortion, whiplash and damage;

**ISO 13577-2:2014(E)**

- shall have end fittings as integral parts of the tubing;
- shall be constructed from suitable material both metallic and/or non-metallic selected for the application duty and not be easily damaged.

Couplings for removable equipment shall ensure a tight connection with the equipment connected and disconnected.

**4.3.1.5 Marking**

The pipework shall be identified with respect to the liquid fuel being carried.

NOTE Identification of fuel pipework is dealt with by national regulations.

**4.3.1.6 Soundness/tightness**

The liquid fuel pipework shall be tight and shall be designed to withstand the internal pressure.

After assembly, the liquid fuel circuit shall be submitted to its test pressure and tested for tightness. The test pressure shall be not less than 1,5 times the maximum working pressure at any point.

Suitable methods for checking the leak tightness are e.g. visible leak, pressure decay monitoring, etc. Instructions concerning the methods and frequency of testing shall be specified in the instruction handbook (see [6.3.3](#)).

In addition to the pressure test on the pipework, all the pressure relief valves shall be tested to ensure their operation at the correct pressure.

The external leakage rate shall not give rise to a dangerous condition, flammable and/or toxic, in the foreseen circumstances of the equipment installation. The frequency of testing to determine the external leakage shall be specified in the instruction handbook.

**4.3.1.7 Fuel pipe heating**

Where the liquid fuel pipe needs to be heated and insulated to maintain the required temperature, safeguards shall be provided to prevent the temperature and/or pressure of the fuel exceeding the maximum design values.

The trace heating system shall include all equipment, such as regulating and shut-off mechanisms. In the case of vapour or liquid heating, the heating system shall be provided with suitable condensate outlets and shut-off valves.

**4.3.1.8 By-passes**

By-passes shall not be fitted in parallel with any automatic shut-off valve except where the by-pass is a stand-by system equipped with an automatic shut-off valve.

**4.3.1.9 Purge points**

Means shall be provided to purge gases safely from the liquid fuel system. The venting of the gases shall take into account, in particular:

- risk of combustion;
- avoidance of recirculation into the combustion chamber;
- avoidance of introduction into drains and pits;
- specific gravity of the gas.

#### 4.3.1.10 Equipment supplied with different liquid fuels

Where a burner is intended for use with more than one liquid fuel, means shall be provided to ensure that the supply pipework of the fuel not being fired is positively isolated (e.g. by physical blank or disconnection).

### 4.3.2 Required safety devices

#### 4.3.2.1 Manual isolating valve

A manually operated isolation valve shall be fitted upstream of the first control device in the liquid fuel circuit. Manual isolation valves shall be so designed or positioned as to prevent inadvertent operation but shall be easily accessible and capable of rapid operation when required.

They shall be so designed that the "OPEN" and "CLOSED" positions are readily distinguishable (e.g. a 90° turn valve if applicable and available).

#### 4.3.2.2 Filter/strainer

Special care shall be taken to prevent the ingress of particles, either from the pipework or from the liquid fuel, which would be detrimental to the operation of the equipment by the incorporation of a suitable filter or strainer immediately downstream of the first manual isolating valve of the TPE. Additional filters/strainers shall be required (e.g. immediately upstream of the automatic shut-off valve). The filter and/or the strainer shall be positioned in such a way that periodic servicing can be carried out easily.

In the event of the installation of a by-pass to the filter and/or the strainer, an identical filtering device shall be installed on the by-pass line.

Filter and/or the strainer shall be checked at intervals specified in the instruction handbook.

#### 4.3.2.3 Pressure relief valve

Where required, the fuel circuit shall be fitted with calibrated pressure relief valves.

NOTE When two valves close simultaneously the pressure in between can rise behind safety level.

#### 4.3.2.4 Liquid fuel pressure regulator

A liquid fuel pressure regulator shall be incorporated where this is necessary for control of the flow rate.

#### 4.3.2.5 Pressure regulation of auxiliary fluids

For auxiliary fluids (e.g. compressed air, steam) automatically operating pressure regulators shall be installed where this is necessary for control of the burner system.

#### 4.3.2.6 Liquid fuel pressure protection

High and low fuel pressure detectors shall be fitted in the case of all low-temperature equipment where operation within preset pressure limits is essential in ensuring the correct flow and atomising conditions. Deviation outside of these limits shall prevent start-up or cause safety shut-down. This function shall meet the requirements of a protective system according to ISO 13577-4.

Pressure detectors shall comply with IEC 60730-2-6 or shall be evaluated to ensure appropriate reaction time and accuracy.

## ISO 13577-2:2014(E)

**4.3.2.7 Liquid fuel temperature protection**

High and low fuel temperature detectors shall be fitted in the case of all low-temperature equipment where operation within pre-set temperature limits is essential in ensuring the correct flow and atomising conditions. Deviation outside of these limits shall prevent start-up or cause safety shut-down.

This function shall meet the requirements of a protective system according to ISO 13577-4.

**4.3.2.8 Automatic shut-off valves**

The liquid fuel distribution circuit shall be under the control of two automatic shut-off valves. Automatic shut-off valves shall comply with ISO 23553-1.

In the event of damage, failure of the electricity supply or actuating fluid, the automatic shut-off valves shall shut off the fuel supply to the burner(s).

Automatic shut-off valve shall be capable of withstanding all backpressure and differential pressure under all process circumstances.

High cycling applications over 100 000 cycles/year (e.g. pulse firing, regenerative burners) shall use only valves that are declared capable of an intended number of cycles. The instruction handbook shall specify the need to check valves for correct operation, the procedure to be adopted and the intervals at which this should be carried out.

The instruction handbook shall specify the need to check automatic shut-off valves for correct operation, the procedure to be adopted and the intervals at which this should be carried out and the requirements for replacement. A means to permit the operator to determine when automatic shut-off valves require replacement shall be supplied.

NOTE It is commonly agreed that valves should be tested annually unless longer testing intervals can be justified by the risk analysis.

All systems shall have the ability for manual leak testing of the automatic shut-off valve.

The automatic shut-off valves shall not open or shall shut off the fuel to the burner when the limit of any safety condition is reached. In this case, the relevant automatic shut-off valves shall be de-energised by a protective system according to ISO 13577-4.

NOTE Examples for safety related conditions to be considered are (but not limited to): minimum and/or maximum liquid fuel flow, minimum and/or maximum liquid fuel pressure, minimum and/or maximum air flow, minimum and/or maximum air pressure, failure of power supply and/or other utilities (e.g. compressed air, steam), failure of heat transfer fluid, fume extraction malfunction, minimum and/or maximum operation temperature, minimum and/or maximum combustion chamber pressure, flame failure, incorrect air gas ratio as referred in [4.3.3.3](#).

It shall only be possible to manually reset (locally or remotely) the lock out of a closed automatic shut-off valve.

Flame failure or process control shut down shall cause the closing of two automatic shut-off valves piped in series except in the following cases where closing a single individual burner shut-off valve is sufficient:

- in case of high-temperature equipment;
- in case of burner equipped with individual positive displacement pump, when the pump is off at the same time as the automatic shut-off valve.

Single automatic shut-off valve shall be fitted with a device proving that the valve is in closed position in a case of a shut-down and creates an alarm and prevents a re-start.

#### 4.3.2.9 Automatic shut-off valves for multiple burners

Where individual burners are equipped with automatic shut-off valves, such valves shall comply with ISO 23553-1, if technically applicable, and their operation shall not adversely affect the safe operation of the remaining burners.

Where 4.3.2.8 requires two automatic shut-off valves, it is permissible for an individual burner to be shut down by a single automatic shut-off valve in the event of flame failure or for process reasons (e.g. thermal input) providing it is a high-temperature equipment.

#### 4.3.2.10 Individual manual shut-off valves for multiple burners

For multiple burners which are independently ignited, each individual burner shall be fitted with a manual shut-off valve.

If fitted, the operation of the manual shut-off valve(s) shall not adversely affect the safety of the system (e.g. the atomizing fluid valve shall be proven open prior to the introduction of liquid fuel).

### 4.3.3 Combustion air and air/fuel ratio

#### 4.3.3.1 Combustion air system

The pipework design shall take into account the properties of combustion air.

All manual control devices (registers, valves, etc.) for the air shall be set in their pre-determined positions and protected against inadvertent movement.

The location of the combustion air intake shall be such as to prevent entry of flue products unless provided by the design [e.g. for reduction of emission of nitrogen oxides ( $\text{NO}_x$ )].

The combustion air system shall be designed in a manner that prevents the back-flow of furnace atmosphere and/or flue gases through combustion equipment.

The air circuit shall be designed so as to avoid oscillations that are potentially dangerous.

The ventilation of the building and TPE shall be such as to allow an adequate supply of process air and combustion air to reach the burner(s)/TPE under all conditions.

#### 4.3.3.2 Air flow and pressure detectors

TPE fitted with forced or induced draught burner(s) shall be fitted with devices for proving adequate air flow during the ignition and operation of the burner.

Air flow failure at any time during the pre-purge, ignition or operation of the burner shall cause safety shut-down and shall cause a lockout. This function shall meet the requirements of a protective system according to ISO 13577-4.

The air-proving device shall be checked in the "no flow" state prior to start-up [e.g. by stopping the combustion air supply or by interrupting the air signal to the device(s) in such a way as to simulate stopping the combustion air supply]. Failure to prove the device in the "no flow" condition shall prevent start-up.

Air flow shall be monitored:

- by pressure detectors or
- by flow detectors.

It shall be shown that any of these devices provide satisfactory and reliable proof of the flow for all operating conditions.

**ISO 13577-2:2014(E)**

Air pressure detectors shall comply with IEC 60730-2-6 or shall be evaluated to ensure appropriate reaction time and accuracy. They shall be suitable for the number of operations foreseeable for the application.

**4.3.3.3 Air/fuel ratio**

The air mass flow shall always be in a ratio with the fuel mass flow in order to ensure safe ignition and that throughout the operating range, a stable and safe combustion is maintained at each individual burner. The ratio needs not be the same value at all operational conditions.

If the variation of pressure and/or temperature of air and fuel does not affect the safety and combustion stability, then correction for pressure or temperature is not required.

Electronic fuel/air ratio controls shall comply with ISO 23552-1 if applicable.

To ensure their reliability, air/fuel ratio controllers shall be used in conditions (temperature, pressure, flow rate) for which they have been designed. These conditions and instructions for maintenance shall be specified in the instruction handbook.

In case other methods/technologies are used for the ratio control and depending on the combustion air and liquid fuel properties, additional protective measures shall be applied according to the results of the risk assessment (e.g. air/fuel ratio monitoring by protective system according to ISO 13577-4),

**4.3.4 Liquid fuel atomisation**

Burners for liquid fuels shall be equipped where applicable with fuel atomizing systems to permit their correct combustion.

Measures shall be taken to prevent the liquid fuel from entering the atomizing fluid pipe and vice versa. If the atomizing fluid is a combustible gas, then the requirements of the relevant subclauses of [4.2](#) shall apply.

**4.3.5 Burners****4.3.5.1 Main burners**

All burners shall be suitable for the working conditions and shall provide operating safety for:

- the fuels used (type, pressure, etc.);
- the operating conditions (pressure, temperature, atmosphere, etc.);
- the nominal input rate and range of regulation (maximum and minimum capacity);
- ease of visual monitoring (sight glasses, sight holes, etc.).

**4.3.5.2 Ignition system**

For safety requirements, pilot burner(s) shall be treated as main burners and this part of ISO 13577 shall apply.

Any direct ignition device or combination of the ignition device and the pilot burner in automatic installations shall form an integral part of the main burner system.

In the case of installations for controlled manual operation, the ignition assembly shall be capable of being mounted on the main burner in one way only and in such a way that it occupies a fixed position with respect to the burner to be ignited.

The construction and location of any pilot burner shall be such that, under all operating conditions, the ignition flame remains stable and of such a shape that the main flame is ignited.

The ignition device shall be reliable and of sufficient capacity, so that immediate, low noise and smooth ignition is obtained.

Where use is made of a portable pilot burner or ignition device:

- the pilot burner or ignition device shall be capable of being fitted in one way only — if necessary the correct position shall be monitored;
- the connections for fuel, air, ignition energy shall be so designed that a reliable link-up is obtained, and errors of fitting of connections are avoided.

If the fuel used for the pilot burner is gaseous, then the requirements of the relevant subclauses of [4.2](#) shall apply.

#### 4.3.5.3 Permanent pilots

Where used, a permanent pilot(s) shall be supplied with a clean fuel (e.g. natural gas, LPG, diesel) of constant quality and be fitted with automatic burner control systems. This automatic burner control systems may be the automatic burner control systems of the ignited main burner, when the safety of the equipment is not compromised.

#### 4.3.5.4 Burner capacity control

In any combustion system, the turndown ratio shall be such that the burner(s) is/are fully stable at all firing conditions.

#### 4.3.5.5 Flue gas venting

Flue gases shall be vented in a safe way.

TPE with a closed combustion chamber or combustion chamber with at least three surrounding walls shall be equipped with a flue system. The cross sectional area of the flue system has to be calculated according to the volume, the pressure and the temperature of the flue gases (products of combustion, excess air and process emissions).

If the flue gases are extracted by a fan or the draught is controlled by a damper and the risk is not adequately reduced by the inherently safe design or mechanical design, the system shall be fitted with a safety device to effect a safety shut down of the burner(s) or a switching over to a backup duct system in the event of a failure in the flue venting. This function shall meet the requirements of a protective system according to ISO 13577-4.

For all TPE equipment burners supplied without a flue system, the combustion products shall be directed away from the workplace. The instruction handbook shall refer to the need for sufficient venting to ensure the correct air quality for the operator.

NOTE EN 525 gives useful information on maintaining the air quality in workshops

### 4.3.6 Automatic burner control systems

#### 4.3.6.1 General

The main flame and, if applicable, the pilot burner flame shall be supervised by means of an automatic burner control system complying with IEC 60730-2-5. Exceptions are only permitted when specified in this part of ISO 13577 (e.g. see [4.3.6.2](#) and [4.3.6.3](#)).

For systems where the pilot burner remains in use during main burner operation, separate flame detector devices to supervise the pilot and main flames shall be fitted. The main flame detector device shall be so positioned that it cannot in any circumstances detect the pilot flame.

**ISO 13577-2:2014(E)**

Where the pilot burner and the main burner are each provided with their own flame detector device, the pilot flame shall not influence the response of the main flame sensor. A single flame detector device shall be sufficient:

- for systems where the pilot flame is extinguished during main burner operation;
- for any metallic fuel fired radiant tubes, explosion resistance and equipped with a burner fitted with permanent pilot burner.

Where fitted, flame detector device shall be unresponsive to unintended radiation.

If necessary for process reasons, the characteristics of the system may differ from the requirements specified in ISO 23553-1 providing the levels of safety and reliability are not reduced.

Where a burner is required to fire continuously for periods in excess of 24 h, the automatic burner control system shall be designed for continuous operation.

The detection of a flame when there should not be a flame or a defect of the automatic burner control system or the protective system shall result into lock-out.

**4.3.6.2 Low-temperature equipment**

Low-temperature equipment fitted with a single burner shall be equipped with an automatic burner control system in accordance with [4.3.6.1](#).

For low-temperature multiple burner equipment, each burner shall be equipped with an automatic burner control system.

Only one of the burners may be equipped with an automatic burner control system operating continuously provided that the burners guarantee stable combustion throughout the range of regulation, are on the same air/fuel ratio control system and are arranged adjacent and in such a way that, if one of them is extinguished, it is re-ignited quickly and smoothly by the flame from the next burner. This procedure shall not apply to burners controlled by "on/off" systems.

**4.3.6.3 High-temperature equipment**

During high-temperature operation, the temperature shall be monitored. In the event the temperature falls below the limit, the control system shall automatically shut off the liquid fuel supply or shall switch over to flame supervision by means of an automatic burner control system according to [4.3.6.1](#). This function shall meet the requirements of a protective system according to ISO 13577-4.

The temperature limit for high-temperature operation shall not be less than 750 °C and the temperature shall be detected at the coldest point.

**NOTE** At radiant tube burner systems, the ignition point is inside the radiant tube. The temperature inside the tube and prior to ignition may well be much lower than in the chamber in which the radiant tube is placed. This temperature difference has to be taken into consideration when designing.

During start-up period, flame supervision, either by means of an automatic burner control system or by the operator, shall be provided when the combustion chamber wall temperature is below the temperature limit for high-temperature operation. For TPE intended to be started more than 4 times a year, flame supervision below 750 °C shall be by means of an automatic burner control system. Additional burners that operate during high-temperature operation without flame supervision shall be isolated from the liquid fuel supply by two automatic shut-off valves until the temperature is above the limit for high-temperature operation. This function shall meet the requirements of a protective system according to ISO 13577-4.

The high-temperature operation, the method/procedure for flame supervision during start-up period and switch over to high-temperature shall be described in the instruction handbook.

### 4.3.7 Start-up of the heating system and burner ignition

#### 4.3.7.1 Pre-purging of the combustion chamber

Except where specified below, start-up or restart after a lock-out shall not be initiated until adequate steps have been taken to ensure that no combustible mixture is present in the combustion/processing chamber, connected spaces and flue products evacuation circuit (heat exchangers, dust extractors). This condition shall be achieved by means of a period of pre-purging immediately prior to ignition or within a time to be specified in the instruction handbook.

The pre-purge time shall be such as to ensure that the concentration of any combustible products in any part of the combustion chamber/processing chamber and flue duct is below 25 % of the Lower Flammable Limit of the liquid fuel; this being calculated with the combustion chamber/processing chamber and the flue duct assumed as being initially 100 % filled with flammable gases.

NOTE Fuel oil can collect and remain in liquid state until vaporized thereby extending the time required for pre-purge.

In general, five complete air changes of the combustion chamber/processing chamber and flue duct will suffice. The air flow rate used for a pre-purge shall be at least 50 % of the maximum combustion air flow rate. In the case of natural draught, the condition to achieve the above requirements shall be defined in the instruction handbook.

The pre-purge time and purge procedure and or methodology shall be specified in the instruction handbook.

The system for ensuring correct pre-purge time and the airflow shall meet the requirements of a protective system according to ISO 13577-4.

When the combustion chamber is proved to be at a temperature above 750 °C (as defined for high-temperature equipment) pre-purge may be omitted.

Inert or non-flammable gases shall be used instead of air if required by the equipment or process. Other methods of ensuring that the combustion chamber and connected spaces do not contain flammable gases can be utilized providing that the equivalent level of safety is achieved.

Restart after a lock-out condition shall commence with a pre-purge.

In multiple burner equipment a single burner may be started without pre-purge in the following cases:

- when restarting a burner after shut-down for control purpose where the burner is fitted with an independently supervised permanent or alternating pilot;
- when one or more burners remain alight in the same combustion chamber of the burner to be re-ignited and the burner(s) remaining in operation shall provide ignition of any unintended release of fuel through other burners that are not in operation without causing a hazard (e.g. deflagration);
- where the burner is fitted with two automatic shut-off valves that close simultaneously and a valve proving is conducted at each burner start;
- with pulse fired burners, equipped with two automatic shut-off valves that close simultaneously and provided the automatic shut-off valves are declared to be suitable for the intended number of cycles and on/off cycling rate by the manufacturer of the automatic shut-off valve;
- with regenerative burners equipped with two automatic shut-off valves that close simultaneously and provided the automatic shut-off valves are declared to be suitable for the intended number of cycles and on/off cycling rate by the manufacturer of the automatic shut-off valve;
- when restarting a radiant tube burner after shut-down for control purpose provided the radiant tube is resistant to explosion and the burners is equipped with two automatic shut-off valves that close simultaneously and that the radiant tube burner is equipped with an ignition device according to [4.3.5.3](#).

**ISO 13577-2:2014(E)**

In the case of a flame failure of one burner of a group of radiant tube burners, a maximum of one re-start without pre-purge is permitted before lock-out after a flame failure, if:

- each burner has an automatic burner control system and
- the exhaust system dilutes the ignitable fuel-air-mixture inside the exhaust system below 25 % of the LFL or the radiant tube, the burner and the connection to the exhaust are designed for the maximum pressure increase that is possible during ignition and
- the liquid fuel supply to each radiant tube burner is equipped with an automatic shut-off valve complying with ISO 23553-1.

**4.3.7.2 Start-up of the fuel supply**

Start-up of the fuel supply and burner(s) shall be possible only when:

- the installed air and liquid fuel proving devices (e.g. air flow, fuel pressure, atomizing fluid pressure when required) have been checked to ensure that they are in the correct operating condition for start-up and
- all relevant interlocks [e.g. burner(s) position, valve(s) position, flue damper(s)] have been proved to be in the correct position.

**4.3.7.3 Start fuel flow rate**

The energy released during the start-up of the burners(s) shall be limited and the maximum pressure rise from a delayed ignition shall not cause any damage to the TPE (see [Table 4](#)).

The start fuel flow rate shall be controlled by control and/or a protective system according to ISO 13577-4 based on the outcome of the risk assessment.

**4.3.7.4 Ignition**

The ignition process shall be initiated immediately or within the time to be specified in the instruction handbook after the conclusion of the pre-purging stage.

Where the main burner is ignited by means of a pilot burner, the liquid fuel supply to the main burner shall be shut off during ignition of the pilot burner. The burner input rating shall be such that the maximum pressure in the combustion chamber/processing chamber and in the flue ways does not create a hazard and hazardous situations in the pipework are prevented. The automatic shut-off valve(s) of the main burner shall be opened only when the pilot burner flame has been proved.

Where air enriched with oxygen or oxygen alone is the oxidising agent for the combustion of a fuel, (commonly called oxy/fuel firing), then the ignition procedures and times for such systems requires specific additional design attention to ensure the equivalent levels of safety.

**4.3.7.5 Maximum safety times**

The ignition time shall not exceed the values given in [Table 4](#).

**Table 4 — Maximum safety times**

1	2	3	4
Heat input	Direct main burner ignition at full rate	Direct main burner ignition at reduced rate $Q_s$	Reduced rate $Q_s$ by pilot burner
$Q_{F\max}$ in kW	$t_{s\max}$ in s	$t_{s\max}$ in s $Q_{s\max}$ in %	$t_{s\max}$ in s $Q_{s\max}$ in %
< 300	$t_{s\max} = 10$	$t_{s\max} = 10$	$t_{s\max} = 10$
> 300 < 1 000	$t_{s\max} = 5$	$t_{s\max} = 5$	$t_{s\max} = 5$
> 1 000 < 5 000	not allowed	$Q_s \leq 100$ kW $Q_{s\max} \leq 70$ % $t_{s\max} = 5$	$Q_s \leq 1\,000$ kW $t_{s\max} = 5$
> 5 000	not allowed	$Q_{s\max} \leq 35$ % $t_{s\max} = 5$	$Q_{s\max} \leq 50$ % $t_{s\max} = 5$
$Q_s$ = start heat input expressed as a percentage of $Q_{F\max}$ $Q_{s\max}$ = maximum start heat input expressed as a percentage of $Q_{F\max}$ $Q_{F\max}$ = maximum heat input in kilowatts $t_{s\max}$ = maximum safety time in seconds			

Only if required for process reasons or special cases of equipment construction and if the above mentioned ignition safety times cannot be used, the function and values of the ignition safety time shall differ from those given in [Table 4](#) provided the safety of the TPE is not endangered. In any case the safety time shall not exceed 10 s.

#### 4.3.7.6 Flame failure on start-up

In the event of failure occurs during the safety time, the burner shall go to lock-out.

However, re-cycling is acceptable providing equipment safety is not compromised (e.g. LFL-level in the combustion chamber does not exceed 25 %). The conditions and the time delay between recycle and the number of re-cycles, which shall not exceed two, shall be specified in the instruction handbook. Recycle(s) shall be controlled by a protective system according to ISO 13577-4. If there is no flame signal at the end of these re-cycles the burner shall go to lock-out.

#### 4.3.7.7 Flame failure during operation

In the event of flame failure during operation, the burner shall go to lock-out.

However, safety shut-down is acceptable providing equipment safety is not compromised (e.g. LFL-level in the combustion chamber does not exceed 25 %). Not more than one re-cycle shall be permitted, the condition for which shall be specified in the instruction handbook. If there is no flame signal at the end of this re-cycle, the failing burner shall go to lock-out.

The total closing time shall not exceed 3 s. However, in cases where there is no recycle without purge and if the LFL-level in the combustion chamber does not exceed 25 % the total closing time shall not exceed 5 s.

A recycle on a single burner system requires a complete recycle including pre-purge.

## 4.4 Multiple fuels

### 4.4.1 General

Equipment heated with multiple fuels may be fitted with burners supplied with two or more types of fuel, i.e. gaseous, vapour, liquid, operating either simultaneously or separately.

## ISO 13577-2:2014(E)

### 4.4.2 Fuel circuit

Each type of fuel shall be distributed to the burner(s) by means of an independent system. This system shall be constructed in accordance with the requirements of [4.2](#) and [4.3](#) as appropriate.

In particular, each burner shall be fitted with automatic shut-off valves for each type of fuel. In addition, the flame supervision system shall be chosen in such that it complies with the specifications appropriate to the types of fuel used.

Means shall be provided to ensure that the supply pipework of each individual fuel can be positively isolated from the other fuels whether or not non-return valves are fitted.

### 4.4.3 Combustion air supplies

It is acceptable to use a common combustion air system for all fuels.

### 4.4.4 Operation of the safety devices

Where malfunctions that affect only one type of fuel occur, the individual safety shut-off device relating to that fuel shall close.

Where a fuel supports the combustion of other fuels, the safety device of the assisted fuel shall also operate as intended.

Simultaneous closure of the safety shut-off devices installed for each type of fuel shall be ensured under all other circumstances given in [4.2.2.6](#) and [4.3.2.8](#).

### 4.4.5 Air/fuel ratio

For each individual or combination of fuels, the requirements specified in [4.2.3.3](#) and [4.3.3.3](#) shall apply.

The air/fuel ratio control function shall meet the requirements of a protective system according to ISO 13577-4 if applicable.

## 4.5 Oxygen or oxygen-enriched combustion air (OOECA)

### 4.5.1 General

For the purpose of [subclause 4.5](#), oxygen or oxygen-enriched combustion air containing more than 25 % oxygen is named as oxygen. The application of oxygen or oxygen-enriched combustion air needs particular consideration. Oxygen or oxygen-enriched air shall be released only when essential and in a safe discharge area. The hazards related to the use and handling of oxygen shall be specified in the instruction handbook.

### 4.5.2 Suitability for oxygen service

Due to the high ignition hazard of flammable material in contact with oxygen, all components coming into contact with oxygen shall be prepared, cleaned and sufficiently free of flammable substances (e.g. dust, grease, particulates) prior to start-up. They shall be suitable for oxygen service.

### 4.5.3 Sealing materials for oxygen pipework

Sealing materials shall be suitable for application at the particular pressure levels, installation methods and operating temperatures and shall meet the safety requirements.

Suitable metallic sealing materials for oxygen pipework are those indicated in [Table 6](#), Column 2.

#### 4.5.4 Pipework

The design and material of pipework and their equipment and connections shall be suitable for oxygen and the intended pressures, velocities and temperatures.

Suitable materials for pipework are those indicated in [Table 6](#).

In case carbon steel or low-alloyed steel is used right angle impingement of gaseous oxygen onto the pipe walls shall be avoided and the minimum bending radius shall be at least 5 times of its piping diameters.

Depending on the operating pressure the flow velocity shall be limited due to possible presence of particulates. See [4.5.5](#)

NOTE Reference [\[19\]](#) provides guidance on suitability assessments.

A manually operated isolation valve shall be fitted at the inlet of the TPE's oxygen pipe system.

Filter(s) shall be fitted at the inlet of the oxygen pipe systems to prevent ingress of particulates (e.g. rust).

#### 4.5.5 Pipes velocities

Velocities for temperature between  $-10\text{ °C}$  and  $+200\text{ °C}$  shall not exceed the values specified in [Table 5](#).

**Table 5 — Pipe velocities for oxygen**

Pressure	Velocity
A) for carbon and stainless steels piping and impinging flow	
0,3 MPa (abs) < $P \leq 1,5$ MPa (abs)	30 m/s
1,5 MPa (abs) < $P \leq 10$ MPa (abs)	$P \times V = 45 \text{ MPa} \times \text{m/s}$
10 MPa (abs) < $P \leq 20$ MPa (abs)	4,5 m/s
B) for carbon and stainless steels piping and non-impinging flow	
0,3 MPa (abs) < $P \leq 1,5$ MPa (abs)	60 m/s
1,5 MPa (abs) < $P \leq 10$ MPa (abs)	$P \times V = 80 \text{ MPa} \times \text{m/s}$
10 MPa (abs) < $P \leq 20$ MPa (abs)	8 m/s
C) for copper, nickel, and copper/nickel alloys piping	
up to 6,5 MPa	no velocity limit

For piping after pressure reducing or control valves, the velocity for impinging flow shall be applied. If the velocity for impinging flow is exceeded, the pipe shall be straight for a minimum length of 8 pipe diameters and fabricated from stainless steel [wall thickness shall be  $\geq 3,18 \text{ mm}$  ( $\geq 1/8 \text{ inch}$ )], copper, nickel or Cu/Ni alloys.

For operating temperatures exceeding  $200\text{ °C}$  or below  $-10\text{ °C}$ , these materials and conditions shall not apply. In this case, the limits of use are to be specified in the instruction handbook.

#### 4.5.6 Fittings

The design and material of fittings for gaseous oxygen such as automatic shut-off valves, control devices and non-return valves shall be suitable for oxygen at the intended pressures and temperatures.

Suitable materials for housings and built-in parts of fittings and their sealing materials are those indicated in [Table 6](#).

Fittings for gaseous oxygen at an operating temperature exceeding  $200\text{ °C}$  or below  $-10\text{ °C}$  shall be made of materials which are suitable for these conditions.

## ISO 13577-2:2014(E)

**4.5.7 Blow off and venting lines**

Oxygen line shall be vented to an area where the release of oxygen will not create a hazard.

**4.5.8 Flexible tubing and couplings**

Hoses, flexible pipes and connections shall be gas-tight.

Hoses and flexible pipes associated with manually operated torches shall be lockable in position by means of fittings within the solidly laid piping. They shall be easily accessible.

Manual torches shall be equipped with a flash back arrestor and a lockable manual shut-off valve upstream of the hose.

**4.5.9 Safety devices against gas backflow**

For oxygen pipework connected to other fluids, it shall be ensured that back-flow cannot occur.

**4.5.10 Safety devices against oxygen backflow in mixture with other substances**

If oxygen is mixed with other substances (e.g. fuel gas, air) it shall be ensured that back-flow cannot occur.

**4.5.11 Material requirements**

Materials in contact with oxygen shall be suitable for the intended operating pressures and temperatures. The installation method has to be selected to ensure that it will be safe in oxygen service.

The materials indicated in [Table 6](#) (depending on the mounting location and the pressure) are suitable for use with oxygen or oxygen enriched combustion air.

**Table 6 — Materials requirements**

Pressure range [MPa]	Materials for housings, built-in components and seals
exceeding 4	copper, copper alloys with a mass proportion of at least 55 %, nickel, nickel-wrought alloys with copper high-alloy Cr-Ni-steels with a mass proportion of Cr and Ni of a total of at least 22 % high-alloy Cr-Si-steels with a mass proportion of Cr of at least 22 %
0 up to 4	copper, copper alloys with a mass proportion of copper of at least 55 % high-alloy Cr-Ni-steels with a mass proportion of Cr and Ni of a total of at least 22 % high-alloy Cr-Si-steels with a mass proportion of Cr of at least 22 %
0 up to 1,6	grey cast iron, at least quality class GG 25, cast iron with nodular graphite, at least quality class GGG 40
0 up to 1	metallic materials (except titanium, zirconium and their alloys)

Besides the metals indicated in [Table 6](#), lead and tin may be used as metallic sealing materials for all pressure ranges.

For gaseous oxygen at an operating temperature exceeding 200 °C or below –10 °C materials which are suitable for these conditions shall be used.

**5 Verification of the safety requirements and/or measures**

[Table 7](#) shall be used as a check list for manufacturers to prepare their own specific table of methods used to verify that the safety requirements and measures described in [Clause 4](#) are complied with and contains references to the respective clauses of this part of ISO 13577.

Table 7 — Verification of the safety requirements and/or measures

Clause	Safety requirements and/or measures	Visual inspection Note 1	Functional test Note 2	Measuring Note 3	Examination of drawings/ Calculations Note 4
<a href="#">4.1</a>	General				
<a href="#">4.2</a>	Gaseous fuels				
<a href="#">4.2.1</a>	Gas pipework				
<a href="#">4.2.1.1</a>	Pipework	X			X
<a href="#">4.2.1.2</a>	Connections	X			X
<a href="#">4.2.1.3</a>	Unconnected pipework	X			X
<a href="#">4.2.1.4</a>	Galvanic Cells	X			X
<a href="#">4.2.1.5</a>	Flexible tubing and couplings	X			X
<a href="#">4.2.1.6</a>	Marking	X			
<a href="#">4.2.1.7</a>	Soundness / Tightness		X2		X
<a href="#">4.2.1.8</a>	Condensate drains	X			X
<a href="#">4.2.1.9</a>	Purge points	X			
<a href="#">4.2.1.10</a>	Blow-off and breather pipes or conduits	X			X
<a href="#">4.2.1.11-1</a>	Pressure relief devices on pipework	X	X1		X
<a href="#">4.2.1.11-2</a>	Flame arrestors on pipework	X			X
<a href="#">4.2.1.12</a>	Pressure oscillations	X			X
<a href="#">4.2.1.13</a>	Equipment supplied with different fuel gases	X			X
<a href="#">4.2.1.14</a>	By-pass	X			X
<a href="#">4.2.1.15</a>	Isolation of required safety devices	X			X
<a href="#">4.2.2</a>	Required safety devices				
<a href="#">4.2.2.1</a>	Manual isolating valve	X			X
<a href="#">4.2.2.2</a>	Filter/strainer	X			X
<a href="#">4.2.2.3</a>	Gas pressure regulator	X	X1		X
<a href="#">4.2.2.4</a>	Low gas protection	X	X1		X
<a href="#">4.2.2.5</a>	High gas protection	X	X1		X
<a href="#">4.2.2.6</a>	Automatic shut-off valve	X	X1		X
<a href="#">4.2.2.7</a>	Valve Proving	X	X1		X
<a href="#">4.2.2.8</a>	Individual manual shut-off valves for burners	X			X
<a href="#">4.2.3</a>	Combustion air and air/fuel ratio				
NOTE 1 Visual inspection is carried out for testing the required characteristics and properties by visual study of the delivered equipment and components.					
NOTE 2 The functional test will show whether the parts in question function in such a way as to satisfy the requirements. "X" means test as described in this part of ISO 13577, "X1" means functional test according to device manufactures specification, "X2" means functional test as described in the instruction handbook.					
NOTE 3 Verification by means of measuring instruments is used to check whether the requirements are fulfilled within the specific limits.					
NOTE 4 Drawings and calculations are used to check whether the design characteristics of the components used the specific requirements.					

Table 7 (continued)

Clause	Safety requirements and/or measures	Visual inspection Note 1	Functional test Note 2	Measuring Note 3	Examination of drawings/ Calculations Note 4
<a href="#">4.2.3.1</a>	Combustion air system	X			X
<a href="#">4.2.3.2</a>	Air and gas flow and pressure detectors	X	X1		X
<a href="#">4.2.3.3</a>	Air/ fuel ratio	X	X1/X2		X
<a href="#">4.2.4</a>	Supply of pre-mixed fuel gas/air				
<a href="#">4.2.4.1</a>	Mixture pipework	X			X
<a href="#">4.2.4.2</a>	Air and gas supply to the mixture circuit	X	X1/X2		X
<a href="#">4.2.5</a>	Burners				
<a href="#">4.2.5.1</a>	Main burners	X			X
<a href="#">4.2.5.2</a>	Radiant Tube burner systems	X			X
<a href="#">4.2.5.3</a>	Ignition device / pilot burner	X	X2		X
<a href="#">4.2.5.4</a>	Burner capacity control	X	X2		X
<a href="#">4.2.5.5</a>	Flue gas venting	X			X
<a href="#">4.2.6</a>	Automatic burner control systems				
<a href="#">4.2.6.1</a>	General	X			X
<a href="#">4.2.6.2</a>	Low-temperature equipment	X			X
<a href="#">4.2.6.3</a>	High-temperature equipment	X	X2		X
<a href="#">4.2.6.4</a>	Automatic burner control systems for burners operating in the open air	X			X
<a href="#">4.2.7</a>	Start-up of the heating system and burner ignition				
<a href="#">4.2.7.1</a>	Pre-purging of the combustion chamber		X2		X
<a href="#">4.2.7.2</a>	Start-up of the fuel supply	X	X2		X
<a href="#">4.2.7.3</a>	Start fuel flow rate	X	X2		X
<a href="#">4.2.7.4</a>	Ignition	X	X2		X
<a href="#">4.2.7.5</a>	Maximum safety times for natural draught burners	X			X
<a href="#">4.2.7.6</a>	Maximum safety times for forced and induced draught burners	X			X
<a href="#">4.2.7.7</a>	Flame failure on start-up		X2		X
<a href="#">4.2.7.8</a>	Flame failure during operation		X2		X
<a href="#">4.3</a>	Liquid fuels				
NOTE 1 Visual inspection is carried out for testing the required characteristics and properties by visual study of the delivered equipment and components.					
NOTE 2 The functional test will show whether the parts in question function in such a way as to satisfy the requirements. "X" means test as described in this part of ISO 13577, "X1" means functional test according to device manufactures specification, "X2" means functional test as described in the instruction handbook.					
NOTE 3 Verification by means of measuring instruments is used to check whether the requirements are fulfilled within the specific limits.					
NOTE 4 Drawings and calculations are used to check whether the design characteristics of the components used the specific requirements.					

Table 7 (continued)

Clause	Safety requirements and/or measures	Visual inspection Note 1	Functional test Note 2	Measuring Note 3	Examination of drawings/ Calculations Note 4
<a href="#">4.3.1</a>	Liquid fuel pipework				
<a href="#">4.3.1.1</a>	General	X			X
<a href="#">4.3.1.2</a>	Connections	X			X
<a href="#">4.3.1.3</a>	Unconnected pipework	X			X
<a href="#">4.3.1.4</a>	Flexible tubing and couplings	X			X
<a href="#">4.3.1.5</a>	Marking	X			X
<a href="#">4.3.1.6</a>	Soundness / Tightness		X2		X
<a href="#">4.3.1.7</a>	Fuel pipe heating	X			X
<a href="#">4.3.1.8</a>	By-passes	X			X
<a href="#">4.3.1.9</a>	Purge points	X			X
<a href="#">4.3.1.10</a>	Equipment supplied with different liquid fuels	X			X
<a href="#">4.3.2</a>	Required safety devices				
<a href="#">4.3.2.1</a>	Manual isolating valve	X			X
<a href="#">4.3.2.2</a>	Filter/strainer	X			X
<a href="#">4.3.2.3</a>	Pressure relief valve	X	X2	X	X
<a href="#">4.3.2.4</a>	Liquid fuel pressure regulator	X	X1/X2		X
<a href="#">4.3.2.5</a>	Pressure regulation of auxiliary fluids	X	X2		X
<a href="#">4.3.2.6</a>	Liquid fuel pressure protection		X1		X
<a href="#">4.3.2.7</a>	Liquid fuel temperature protection		X2		X
<a href="#">4.3.2.8</a>	Automatic shut-off valves	X	X1		X
<a href="#">4.3.2.9</a>	Automatic shut-off valves for multiple burners	X	X1		X
<a href="#">4.3.2.10</a>	Individual manual shut-off valves for multiple burners	X			X
<a href="#">4.3.3</a>	Combustion air and air fuel/ratio				
<a href="#">4.3.3.1</a>	Combustion air system	X			X
<a href="#">4.3.3.2</a>	Air flow and pressure detector	X	X1		X
<a href="#">4.3.3.3</a>	Air/Fuel ratio	X	X1/X2		
<a href="#">4.3.4</a>	Liquid fuel atomisation	X			X
<a href="#">4.3.5</a>	Burners				
NOTE 1 Visual inspection is carried out for testing the required characteristics and properties by visual study of the delivered equipment and components.					
NOTE 2 The functional test will show whether the parts in question function in such a way as to satisfy the requirements. "X" means test as described in this part of ISO 13577, "X1" means functional test according to device manufactures specification, "X2" means functional test as described in the instruction handbook.					
NOTE 3 Verification by means of measuring instruments is used to check whether the requirements are fulfilled within the specific limits.					
NOTE 4 Drawings and calculations are used to check whether the design characteristics of the components used the specific requirements.					

Table 7 (continued)

Clause	Safety requirements and/or measures	Visual inspection Note 1	Functional test Note 2	Measuring Note 3	Examination of drawings/ Calculations Note 4
<a href="#">4.3.5.1</a>	Main burners	X			X
<a href="#">4.3.5.2</a>	Ignition system	X	X2		X
<a href="#">4.3.5.3</a>	Permanent pilots	X	X2		X
<a href="#">4.3.5.4</a>	Burner capacity control	X	X2		X
<a href="#">4.3.5.5</a>	Flue gas venting	X			X
<a href="#">4.3.6</a>	Automatic burner control systems				
<a href="#">4.3.6.1</a>	General	X			X
<a href="#">4.3.6.2</a>	Low-temperature equipment	X			X
<a href="#">4.3.6.3</a>	High-temperature equipment	X	X2		X
<a href="#">4.3.7</a>	Start-up of the heating system and burner ignition				
<a href="#">4.3.7.1</a>	Pre-purging of the combustion chamber		X2		X
<a href="#">4.3.7.2</a>	Start-up of the fuel supply	X	X2		X
<a href="#">4.3.7.3</a>	Start fuel flow rate	X	X2		X
<a href="#">4.3.7.4</a>	Ignition	X	X2		X
<a href="#">4.3.7.5</a>	Maximum safety times	X			X
<a href="#">4.3.7.6</a>	Flame failure on start-up		X2		X
<a href="#">4.3.7.7</a>	Flame failure during operation		X2		X
<a href="#">4.4</a>	Multiple fuels				
<a href="#">4.4.1</a>	General	X			X
<a href="#">4.4.2</a>	Fuel circuit	X			X
<a href="#">4.4.3</a>	Combustion air supplies	X			X
<a href="#">4.4.4</a>	Operation of the safety devices	X	X2		X
<a href="#">4.4.5</a>	Air/fuel ratio		X1/X2		X
<a href="#">4.5</a>	Oxygen or oxygen-enriched combustion air (OOECA)				
<a href="#">4.5.1</a>	General	X			X
<a href="#">4.5.2</a>	Suitability for oxygen service	X			X
<a href="#">4.5.3</a>	Sealing materials for oxygen pipework				X
<a href="#">4.5.4</a>	Pipework	X			X
<a href="#">4.5.5</a>	Pipes velocities	X			X

NOTE 1 Visual inspection is carried out for testing the required characteristics and properties by visual study of the delivered equipment and components.

NOTE 2 The functional test will show whether the parts in question function in such a way as to satisfy the requirements.

"X" means test as described in this part of ISO 13577,

"X1" means functional test according to device manufactures specification,

"X2" means functional test as described in the instruction handbook.

NOTE 3 Verification by means of measuring instruments is used to check whether the requirements are fulfilled within the specific limits.

NOTE 4 Drawings and calculations are used to check whether the design characteristics of the components used the specific requirements.

Table 7 (continued)

Clause	Safety requirements and/or measures	Visual inspection Note 1	Functional test Note 2	Measuring Note 3	Examination of drawings/ Calculations Note 4
<a href="#">4.5.6</a>	Fittings	X			X
<a href="#">4.5.7</a>	Blow off and venting lines	X			
<a href="#">4.5.8</a>	Flexible tubing and couplings	X			X
<a href="#">4.5.9</a>	Safety devices against gas backflow	X			X
<a href="#">4.5.10</a>	Safety devices against oxygen backflow in mixture with other substances	X			X
<a href="#">4.5.11</a>	Material requirements				X
<p>NOTE 1 Visual inspection is carried out for testing the required characteristics and properties by visual study of the delivered equipment and components.</p> <p>NOTE 2 The functional test will show whether the parts in question function in such a way as to satisfy the requirements. "X" means test as described in this part of ISO 13577, "X1" means functional test according to device manufactures specification, "X2" means functional test as described in the instruction handbook.</p> <p>NOTE 3 Verification by means of measuring instruments is used to check whether the requirements are fulfilled within the specific limits.</p> <p>NOTE 4 Drawings and calculations are used to check whether the design characteristics of the components used the specific requirements.</p>					

## 6 Information for Use

### 6.1 General

The manufacturer of the TPE shall provide an instruction handbook which contains the necessary information for the combustion and fuel handling system. The format and content shall comply with 6.4 of ISO 12100:2010.

The information for use shall be written in the user's language and shall contain one copy in the original language chosen by the manufacturer.

The information for use shall contain details for commissioning, start-up and use together with information for test procedure and general maintenance and the intended use defined by the manufacturer.

### 6.2 Marking

The minimum information marked on the TPE is given in Clause 6 of ISO 13577-1:2012.

The pipework shall be identified by colour and/or sign.

### 6.3 Instruction handbook

#### 6.3.1 General

For the combustion and fuel handling system the instruction handbook of the TPE shall at least contain the following details:

- exact description of the combustion and fuel handling system of the TPE and of the safety equipment;

**ISO 13577-2:2014(E)**

- instructions for use and requirements for the training of personnel;
- complete range of application of the combustion and fuel handling system of the TPE (tolerable range of application, if necessary);
- schematic description of the safety functions.

Moreover, the following aspects are to be treated by the instruction handbook:

- operation of combustion and fuel handling system of the TPE only by competent personnel according to the conditions of use defined by the manufacturer;
- information on correct work place of operator.

This handbook shall deal with start-up, operation, normal and emergency shut-down.

**6.3.2 Description of equipment**

The instruction handbook shall contain the following information:

- a description of the combustion and fuel handling system, including as built schematic diagrams of pipework and electrical wiring;
- a list of all safety and control equipment parts with their settings and an indication of the relevant standards;
- a list of equipment settings/adjustments as made during final commissioning;
- a description of any deviations from the requirements of relevant standards in the construction and/or function of parts of the combustion and fuel handling system;
- the requirements for handling the waste products of combustion from the TPE.

All the information given on the marking plate(s) shall be repeated together with information relevant to combustion and fuel handling.

**6.3.3 Inspection procedures**

The instruction handbook shall contain details of inspection intervals and periodic checking procedures for:

- leak tightness test of the complete system (as per [4.2.1.7](#) and [4.3.1.6](#));
- leak tightness of all pipework; periodic checking of leak tightness should be carried out at intervals to be determined by consideration of the operating conditions, fuel type and material of construction;
- leak tightness of the TPE and the flue ducts in cases where pressurized combustion is used;
- leak tightness check of the valves;
- leak tightness check of the filter / filter and/or the strainer;
- all safety equipment, especially automatic burner control systems, warning devices and safety shut-off valves;
- combustion quality (e.g. temperatures and/or combustion products analysis), if applicable;
- safety functions in order to ensure that these functions are not impaired by concealed faults or errors.

A documentation form shall be included in which the date, the results and the person who carried out the checks are recorded together with the date of the next inspection.

#### 6.3.4 Commissioning, start-up and operating procedures

The instruction handbook shall provide details of the procedure for commissioning, start up, including preliminary checks (e.g. cleaning of pipework), description of conditions and a list of manually and automatically operated system checks, e.g. opening equipment doors, if applicable.

Attention shall be drawn to the necessity of ensuring that the pipework is free of debris, welding slag, etc. after initial commissioning, before the equipment is put into service, after maintenance or long periods of shutdown.

The instruction handbook shall provide information on special allowances or requirements for:

- pre-purge, e.g. deviation of pre-purge times from standardized conditions in justified cases or waiting time between ignition attempts in the case of natural draught burners;
- the exhausting of combustion products;
- the conditions for automatic restart, if applicable;
- the conditions for, and the number of permitted re-cycles.

#### 6.3.5 Shut-down procedures

The instruction handbook shall provide information on any special requirements necessary before fuel shut-off (e.g. evacuation or combustion of flammable atmospheres), and after fuel shut-off (e.g. continuous venting to avoid overheating or blocking of flue dampers in the open position), together with a description of measures to be taken in the event of a safety shut-down.

The instruction handbook shall set down any special requirements for lock-out and/or emergency shut-down and any special measures for subsequent restart.

An information sheet containing the information required by this subclause shall be provided for display at the equipment control panel or at a defined nearest place.

#### 6.3.6 Maintenance procedures

The instruction handbook shall contain details of the maintenance intervals and procedures for all parts that require maintenance, replacement and/or repair of items of safety equipment.

Safety equipment shall be replaced before its useful life time has expired.

The instruction handbook shall specify the suitable cleaning methods and agents for the cleaning of oxygen systems.

Documentation forms with dates of last and next maintenance and the contact information (such as addresses, telephone, fax numbers, e-mail, website and helpdesk coordinates) of maintenance and repair services shall be provided.

#### 6.3.7 Documentation

Provision shall be made for recording revisions to the instruction handbook in the event of modification of the equipment (e.g. by repair, modernisation or replacement of parts, change of operating conditions).

## Annex A (informative)

### List of significant hazards

Table A.1

1	2	3	4	5
Cl.	Hazards	Location	Relevant clauses of ISO 13577-1:2012	Relevant clauses of this part of ISO 13577
<b>Hazards, hazardous situation and hazardous events</b>				
<b>1</b>	<b>Mechanical Hazards</b>			
1.1	High pressure fluid injection or ejection hazard	Pipework	4.2.7	<a href="#">4.2.1.1</a> , <a href="#">4.2.1.2</a> , <a href="#">4.2.1.5</a> , <a href="#">4.2.1.7</a> , <a href="#">4.2.2.3</a> , <a href="#">4.3.1.1</a> , <a href="#">4.3.1.2</a> , <a href="#">4.3.1.4</a> , <a href="#">4.3.1.6</a> , <a href="#">4.3.2.3</a> , <a href="#">4.5.4</a> , <a href="#">4.5.6</a>
<b>2</b>	<b>Electrical Hazards</b>			
2.1	Electrical contact direct or indirect with live parts	Control system, power supply to the machine and connectors	4.3.2	<a href="#">4.1</a>
2.2	Electrostatic phenomena		4.3.3	
<b>3.</b>	<b>Thermal hazards, resulting in:</b>			
3.1	Burns and other injuries by a possible contact of persons with objects or materials with an extreme high-temperature, by flames or explosions and also by the radiation of heat sources.	Burners Environment of the TPE	4.4.1, 4.4.4	
3.2	Damage to health by hot working environment	Environment of the TPE	4.4.5, 6.4.15	
<b>4</b>	<b>Hazards caused by interruption of energy supply</b>			
4.1	Malfunction or break up of components	Burner and accessories		<a href="#">4.2.2.6</a> ; <a href="#">4.3.2.8</a>
4.2	Malfunction or break down of control system	Control system	4.3.6	
4.3	unexpected start-up	Control system	4.3.6	
<b>5</b>	<b>Hazards caused by (temporary) missing and/or incorrectly positioned safety related measures/ means</b>			
5.1	Specific hazard of maintenance and adjusting	Burners, fans, piping, duct, control system		4
<b>6</b>	<b>Hazards generated by materials and substances processed or used by the machinery</b>			
6.1	Hazards from contact with or inhalation of harmful fluids, gases, mists, fumes, and dusts.	Exhaust gases evacuating system Combustion chamber		<a href="#">4.2.1.10</a> , <a href="#">4.2.2.4</a> , <a href="#">4.2.2.5</a> , <a href="#">4.2.3.3</a> , <a href="#">4.2.5.5</a> , <a href="#">4.3.1.1</a> , <a href="#">4.3.1.2</a> , <a href="#">4.3.3.3</a> , <a href="#">4.3.5.5</a> , <a href="#">4.4.5</a> , <a href="#">4.5.1</a>
6.2	Fire or explosion hazard	Burners, fans, piping, duct, control system, combustion chamber	4.4.3.1, 4.4.3.2	4

Table A.1 (continued)

1	2	3	4	5
Cl.	Hazards	Location	Relevant clauses of ISO 13577-1:2012	Relevant clauses of this part of ISO 13577
<b>7</b>	<b>Hazards generated by neglecting ergonomic principles in machinery design, as e.g. hazards from:</b>			
7.1	Hazard of mismatch of design, location or identification of manual controls	Pipework Control system	4.12.2	<a href="#">4.2.2.1</a> , <a href="#">4.3.2.1</a>

## Annex B (informative)

### Typical examples of fuels

#### B.1 Classification of fuels

The classifications below are given as typical examples only and should not be considered as limitations to this part of ISO 13577 where all gaseous and liquid fuels apply.

#### B.2 Gaseous fuels

Gases likely to be used are classified following ISO 6976 into three families in accordance with their Wobbe index:

- 1st family (manufactured gases: e.g. town gas);
- 2nd family (natural gases);
- 3rd family (liquefied petroleum gases);
- other gaseous fuels.

#### B.3 Liquid fuels

Liquid petroleum fuels likely to be used can be classified into different categories in accordance with the value of their viscosity:

- gas-oil fuel-oils;
- light fuel-oils;
- medium fuel-oils;
- heavy fuel-oils;
- very heavy fuel-oils;
- other liquid fuels.

**Annex C**  
(informative)

**Typical example of piping and components**

## ISO 13577-2:2014(E)

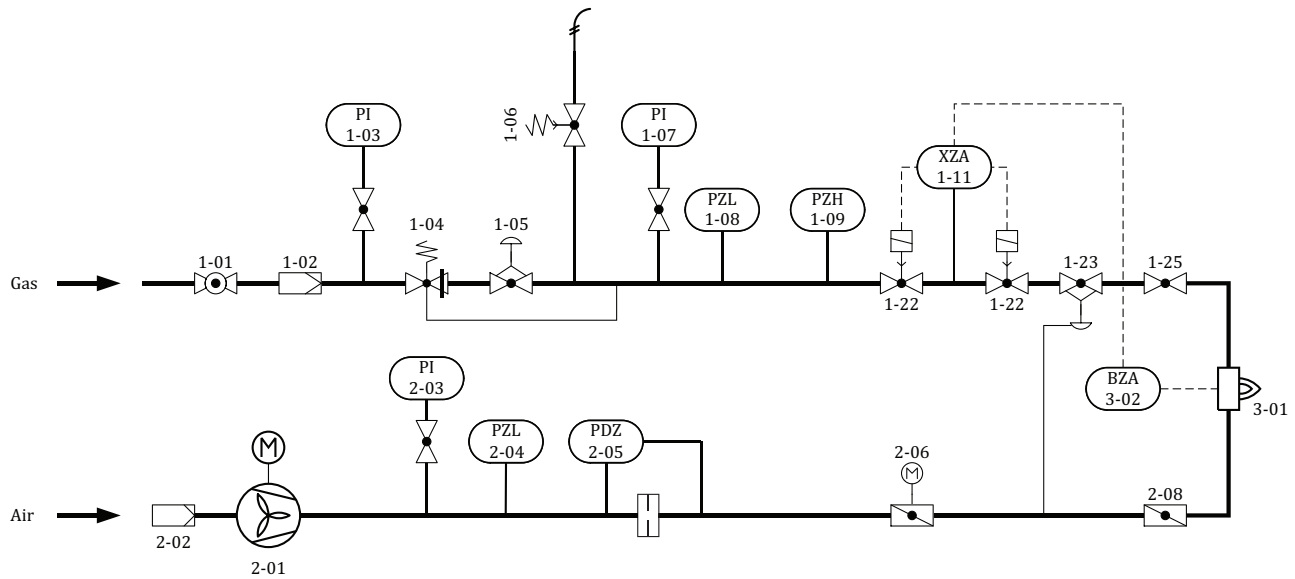
**Key**

- 1-01 manual isolating valve
- 1-02 filter/strainer
- 1-03 pressure indicator (PI) upstream with gauge cock
- 1-04 overpressure cut-off device
- 1-05 gas pressure regulator
- 1-06 relief valve
- 1-07 pressure indicator (PI) downstream with gauge cock
- 1-08 low gas protection (PZL)
- 1-09 high gas protection (PZH)
- 1-11 automatic valve proving (XZA)
- 1-22 burner automatic shut-off valve
- 1-23 pneumatic air/gas ratio control
- 1-25 gas flow adjustment for burner
  
- 2-01 combustion air fan
- 2-02 air inlet filter
- 2-03 pressure indicator (PI) with gauge cock
- 2-04 air pressure detector (PZL)
- 2-05 air flow detector (PDZ)
- 2-06 air flow control valve with motor (M)
- 2-08 air flow adjustment valve for burner
  
- 3-01 burner
- 3-02 automatic burner control/automatic burner control system (BZA)

**Figure C.1 — Single burner equipment**

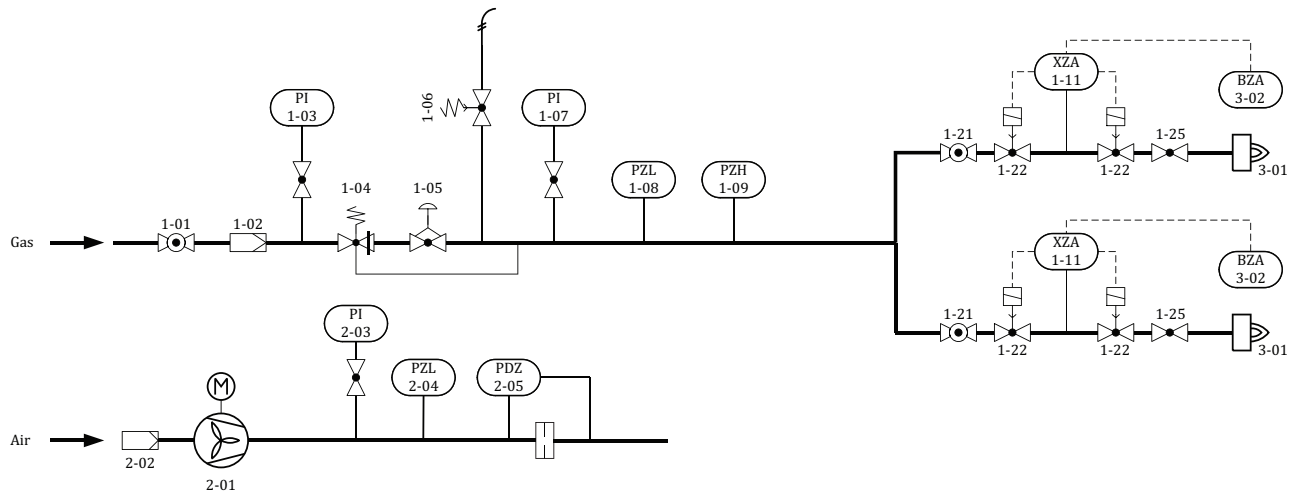
**Key**

1-01	manual isolating valve
1-02	filter/strainer
1-03	pressure indicator (PI) upstream with gauge cock
1-04	overpressure cut off device
1-05	gas pressure regulator
1-06	relief valve
1-07	pressure indicator (PI) downstream with gauge cock
1-08	low gas protection (PZL)
1-09	high gas protection (PZH)
1-11	automatic valve proving (XZA)
1-21	burner manual shut-off valve
1-22	burner automatic shut-off valve
1-25	gas flow adjustment for burner
2-01	combustion air fan
2-02	air inlet filter
2-03	pressure indicator (PI) with gauge cock
2-04	air pressure detector (PZL)
2-05	air flow detector (PDZ)
3-01	burner
3-02	automatic burner control/automatic burner control system (BZA)

**Figure C.2a — Multiple burner equipment – Central pipework – Example a two burners system**

## ISO 13577-2:2014(E)

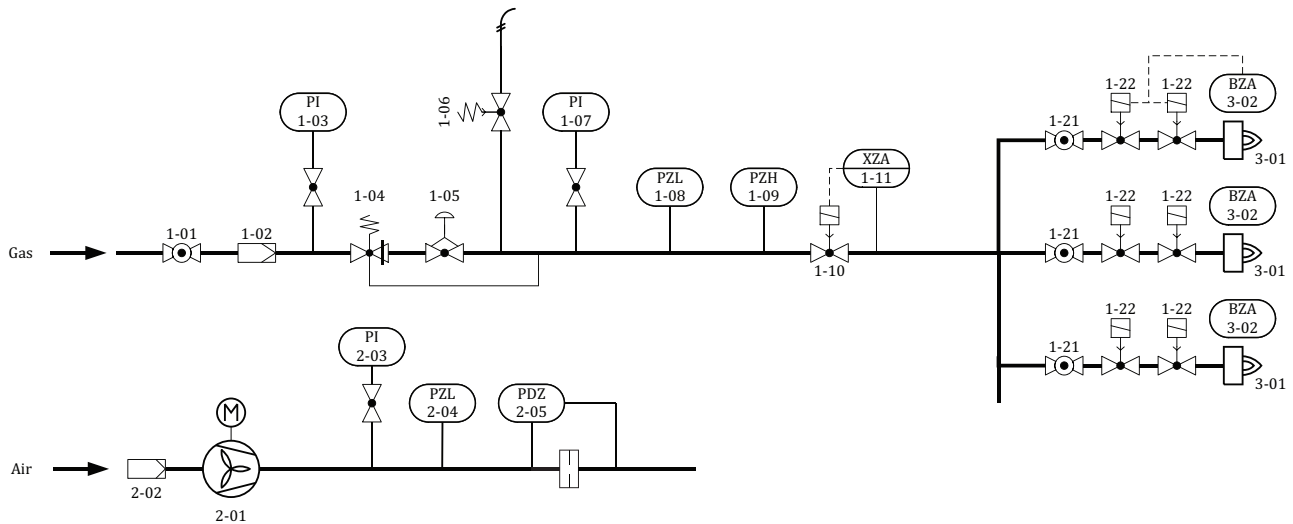
**Key**

1-01	manual isolating valve
1-02	filter/strainer
1-03	pressure indicator (PI) upstream with gauge cock
1-04	overpressure cut-off device
1-05	gas pressure regulator
1-06	relief valve
1-07	pressure indicator (PI) downstream with gauge cock
1-08	low gas protection (PZL)
1-09	high gas protection (PZH)
1-10	central automatic shut-off valve
1-11	automatic valve proving (XZA)
1-21	burner manual shut-off valve
1-22	burner automatic shut-off valve
2-01	combustion air fan
2-02	air inlet filter
2-03	pressure indicator (PI) with gauge cock
2-04	air pressure detector (PZL)
2-05	air flow detector (PDZ)
3-01	burner
3-02	automatic burner control/automatic burner control system (BZA)

**Figure C.2b — Multiple burner equipment – Central pipework – Example b**

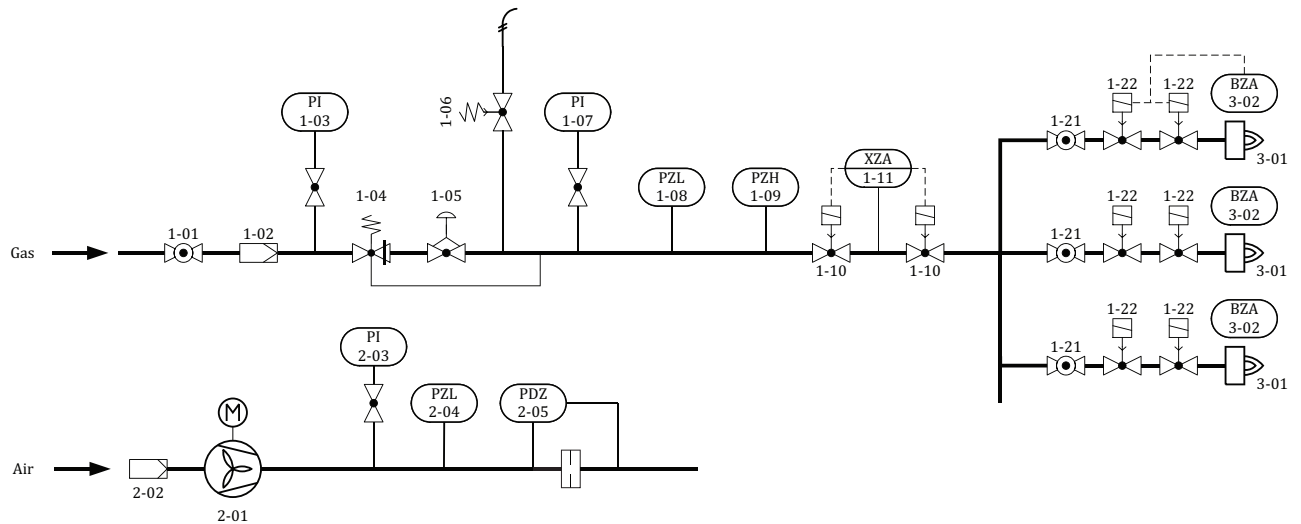
**Key**

1-01	manual isolating valve
1-02	filter/strainer
1-03	pressure indicator (PI) upstream with gauge cock
1-04	overpressure cut-off device
1-05	gas pressure regulator
1-06	relief valve
1-07	pressure indicator (PI) downstream with gauge cock
1-08	low gas protection (PZL)
1-09	high gas protection (PZH)
1-10	central automatic shut-off valve
1-11	automatic valve proving (XZA)
1-21	burner manual shut-off valve
1-22	burner automatic shut-off valve
2-01	combustion air fan
2-02	air inlet filter
2-03	pressure indicator (PI) with gauge cock
2-04	air pressure detector (PZL)
2-05	air flow detector (PDZ)
3-01	burner
3-02	automatic burner control/automatic burner control system (BZA)

**Figure C.2c — Multiple burner equipment - Central pipework - Example c**

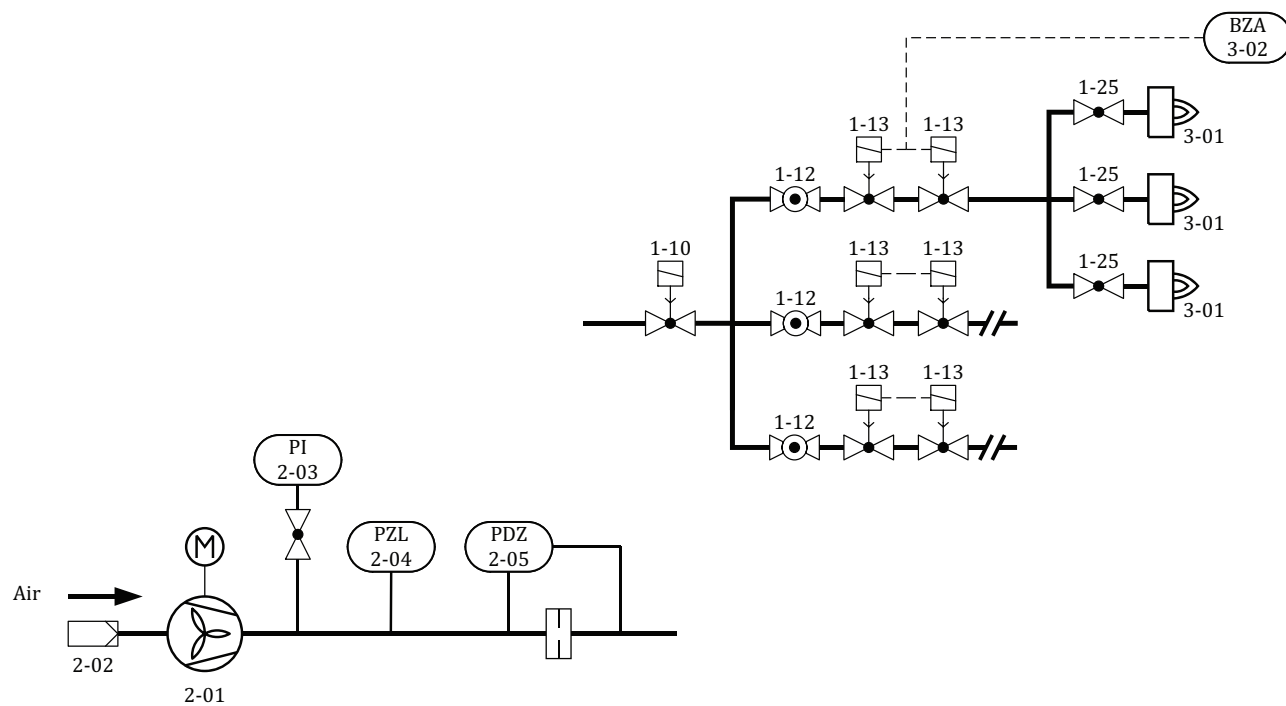
**Key**

1-10	central automatic shut-off valve
1-12	zone isolating valve
1-13	zone automatic shut-off valve
1-25	gas flow adjustment for burner
2-01	combustion air fan
2-02	air inlet filter
2-03	pressure indicator (PI) with gauge cock
2-04	air pressure detector (PZL)
2-05	air flow detector (PDZ)
3-01	burner
3-02	automatic burner control/automatic burner control system (BZA)

**Figure C.3a — Multiple burner equipment - Zone pipework - Example a**

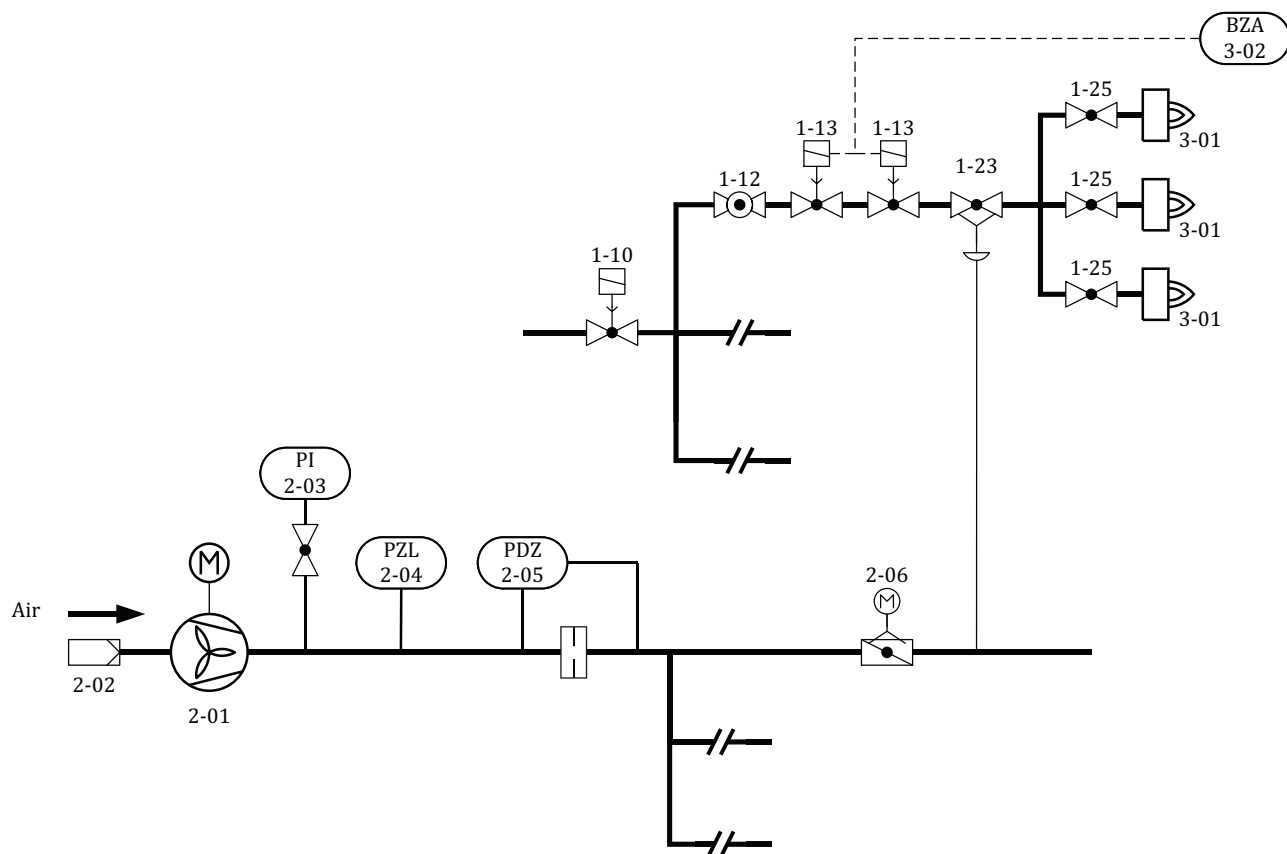
**Key**

1-10	central automatic shut-off valve
1-12	zone isolating valve
1-13	zone automatic shut-off valve
1-23	pneumatic air/gas ratio control
1-25	gas flow adjustment for burner
2-01	combustion air fan
2-02	air inlet filter
2-03	pressure indicator (PI) with gauge cock
2-04	air pressure detector (PZL)
2-05	air flow detector (PDZ)
2-06	air flow control valve with motor (M)
3-01	burner
3-02	automatic burner control/automatic burner control system (BZA)

**Figure C.3b — Multiple burner equipment - Zone pipework - Example b**

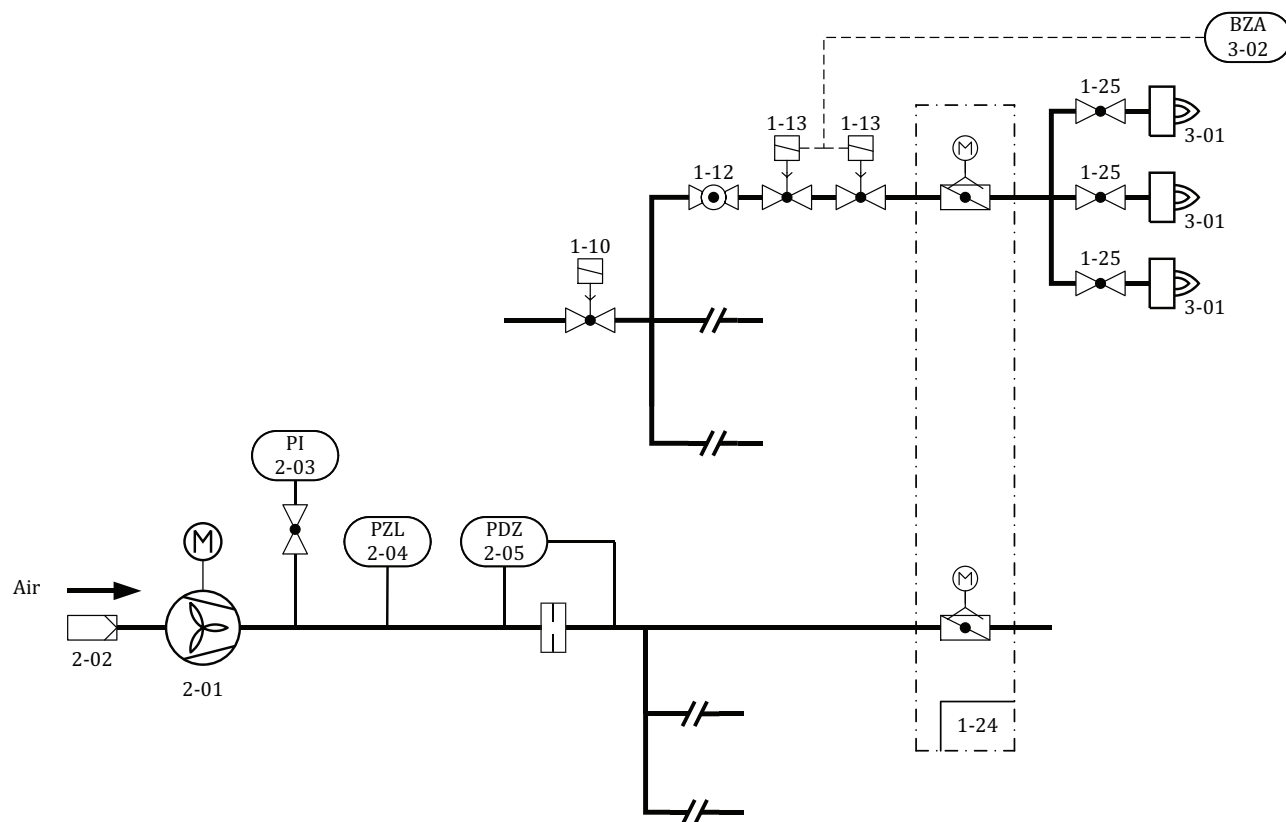
**Key**

1-10	central automatic shut-off valve
1-12	zone isolating valve
1-13	zone automatic shut-off valve (SV)
1-24	electronic air/gas ratio control
1-25	gas flow adjustment for burner
2-01	combustion air fan
2-02	air inlet filter
2-03	pressure indicator (PI) with gauge cock
2-04	air pressure detector (PZL)
2-05	air flow detector (PDZ)
3-01	burner
3-02	automatic burner control/automatic burner control system (BZA)

**Figure C.3c — Multiple burner equipment - Zone pipework - Example c**

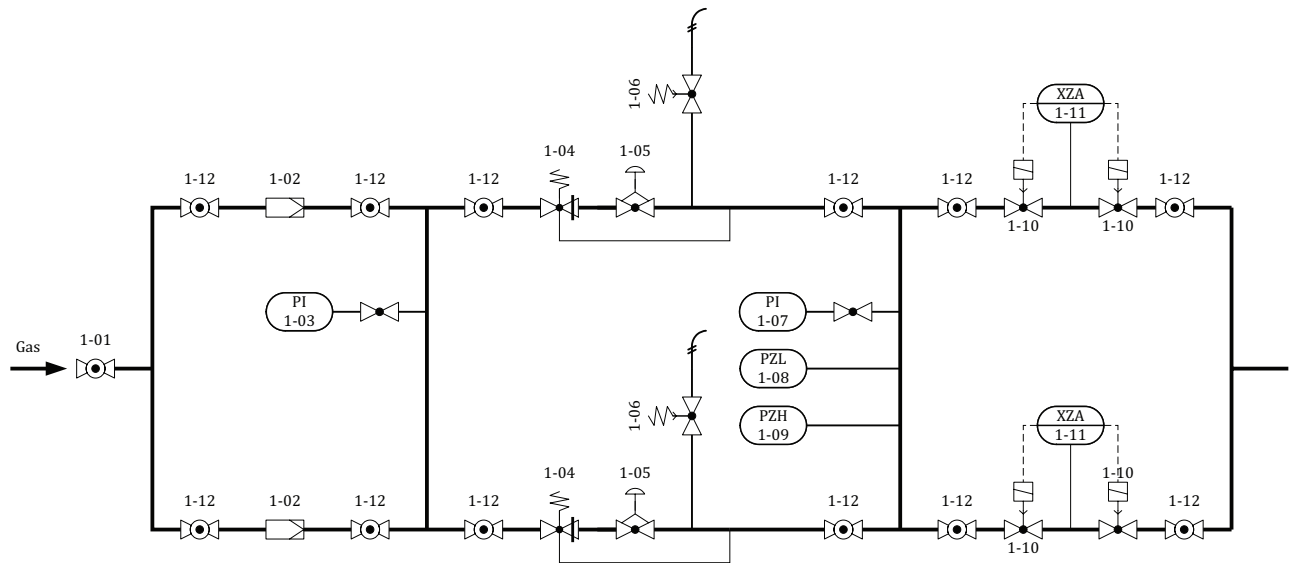
**Key**

- 1-01 manual isolating valve
- 1-02 filter/strainer
- 1-03 pressure indicator (PI) upstream with gauge cock
- 1-04 overpressure cut-off device
- 1-05 gas pressure regulator
- 1-06 relief valve
- 1-07 pressure indicator (PI) downstream with gauge cock
- 1-08 low gas protection (PZL)
- 1-09 high gas protection (PZH)
- 1-10 central automatic shut-off valve
- 1-11 automatic valve proving (XZA)
- 1-12 zone isolating valve

**Figure C.4 — Redundant central pipework**

## ISO 13577-2:2014(E)

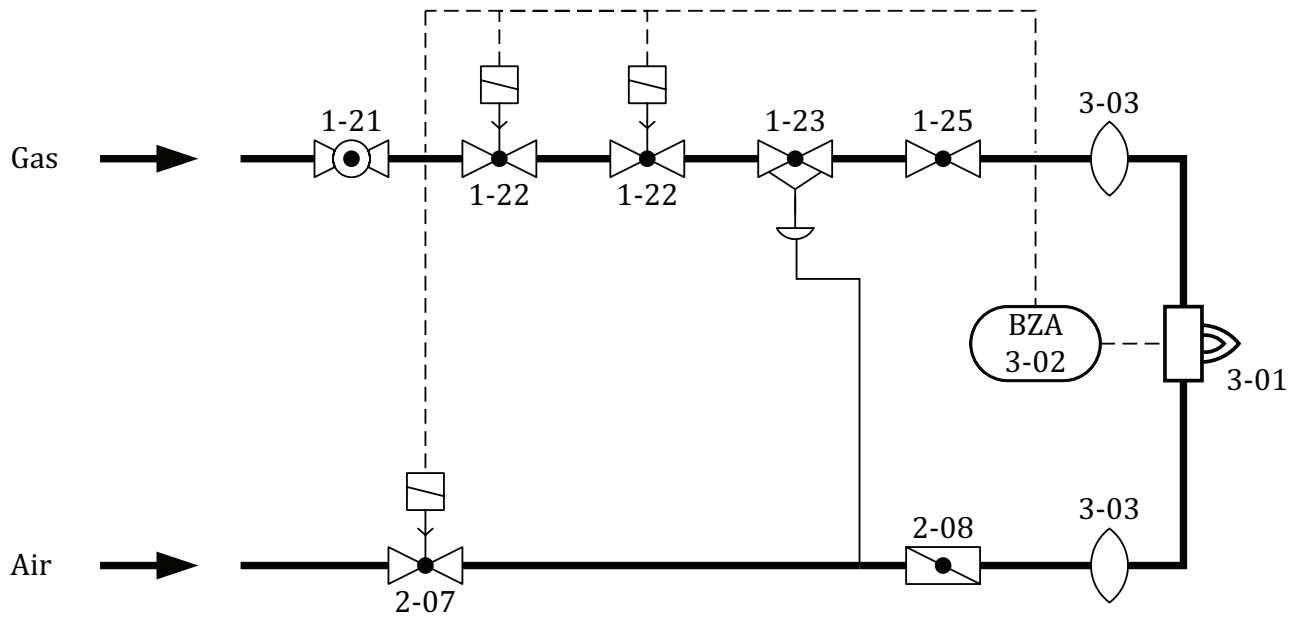
**Key**

- |      |  |
|------|--|
| 1-21 | burner manual shut-off valve                                   |
| 1-22 | burner automatic shut-off valve)                               |
| 1-23 | pneumatic air/gas ratio control                                |
| 1-25 | gas flow adjustment for burner                                 |
| 2-07 | air flow valve for burner                                      |
| 2-08 | air flow adjustment valve for burner                           |
| 3-01 | burner   |
| 3-02 | automatic burner control/automatic burner control system (BZA) |
| 3-03 | compensator  |

**Figure C.5 — Impulse firing installation (burner pipework)**

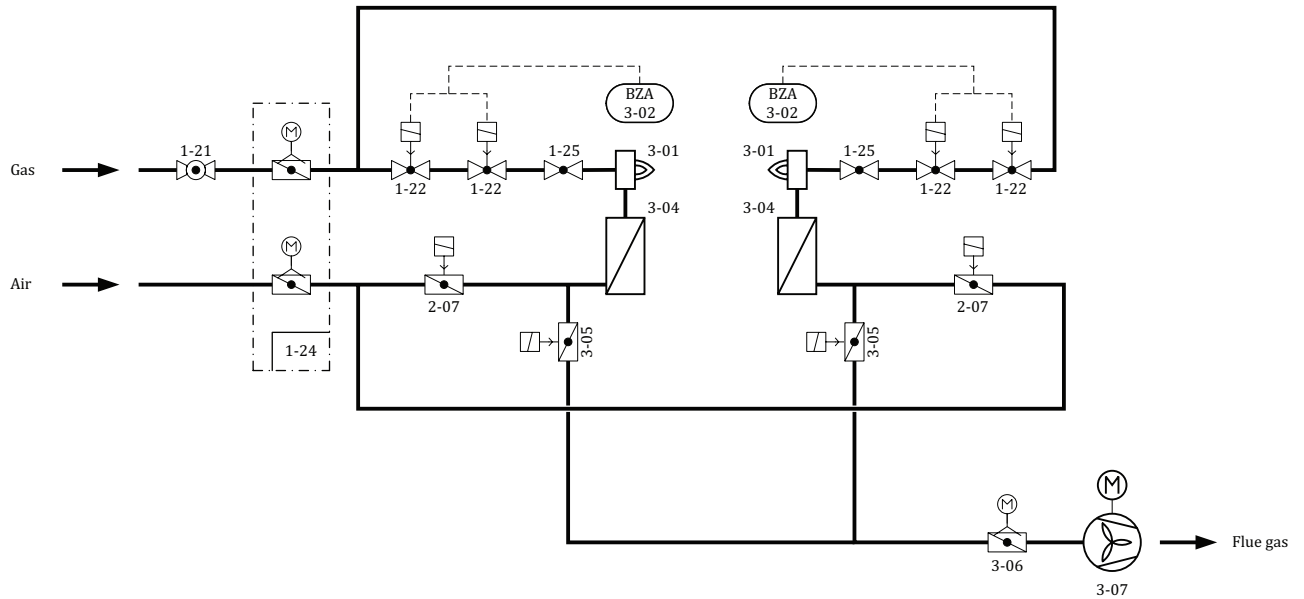
**Key**

- 1-21 burner manual shut-off valve
- 1-22 burner automatic shut-off valve
- 1-24 electronic air/gas ratio control
- 1-25 gas flow adjustment for burner
  
- 2-07 air flow valve for burner
  
- 3-01 burner
- 3-02 automatic burner control/automatic burner control system (BZA)
- 3-04 regenerator
- 3-05 flue gas valve
- 3-06 flue gas flow control valve with motor (M)
- 3-07 flue gas fan

**Figure C.6 — regenerative burner pipework**



## Annex D (informative)

### Methods for burner start-up

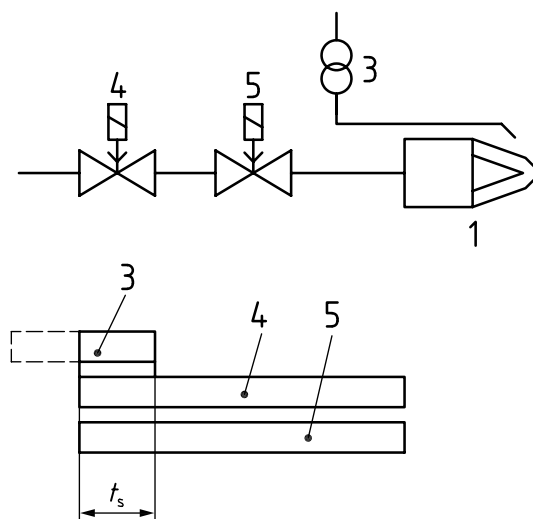

#### Key

- 1 burner
- 3 ignition
- 4 1st shut-off valve
- 5 2nd shut-off valve
- $t_s$  safety time

**Figure D.1 — Direct main burner ignition at full rate  
(see [Table 3](#), Column 2,  $Q_{F \max} \leq 120$  kW)**

## ISO 13577-2:2014(E)

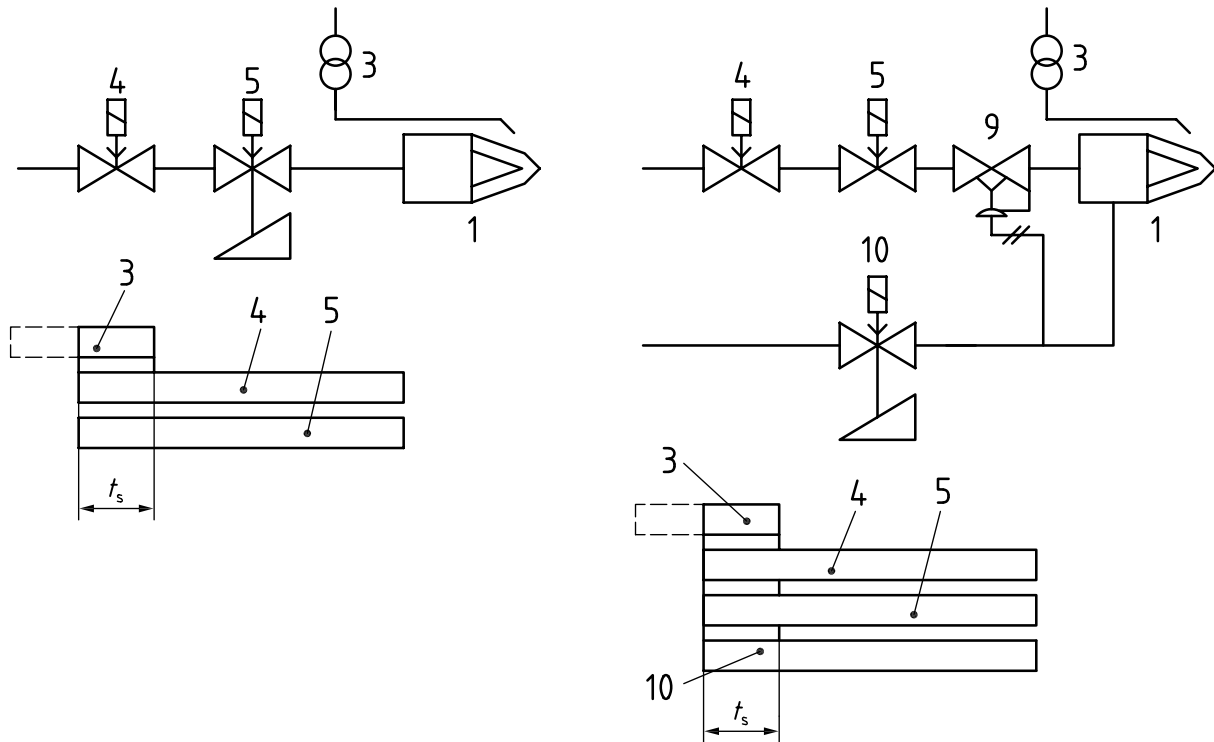
**Key**

- 1 burner
- 3 ignition
- 4 1st shut-off valve
- 5 2nd shut-off valve slow opening

$t_s$  safety time

- 1 burner
- 3 ignition
- 4 1st shut-off valve
- 5 2nd shut-off valve
- 9 air/gas ratio control (PDCV)
- 10 air valve slow opening
- $t_s$  safety time

**Figures D.2 and D.2a — Direct main burner ignition at reduced rate with slow opening valve  
(see [Table 3](#), Column 3,  $Q_{F \max} \leq 360$  kW)**

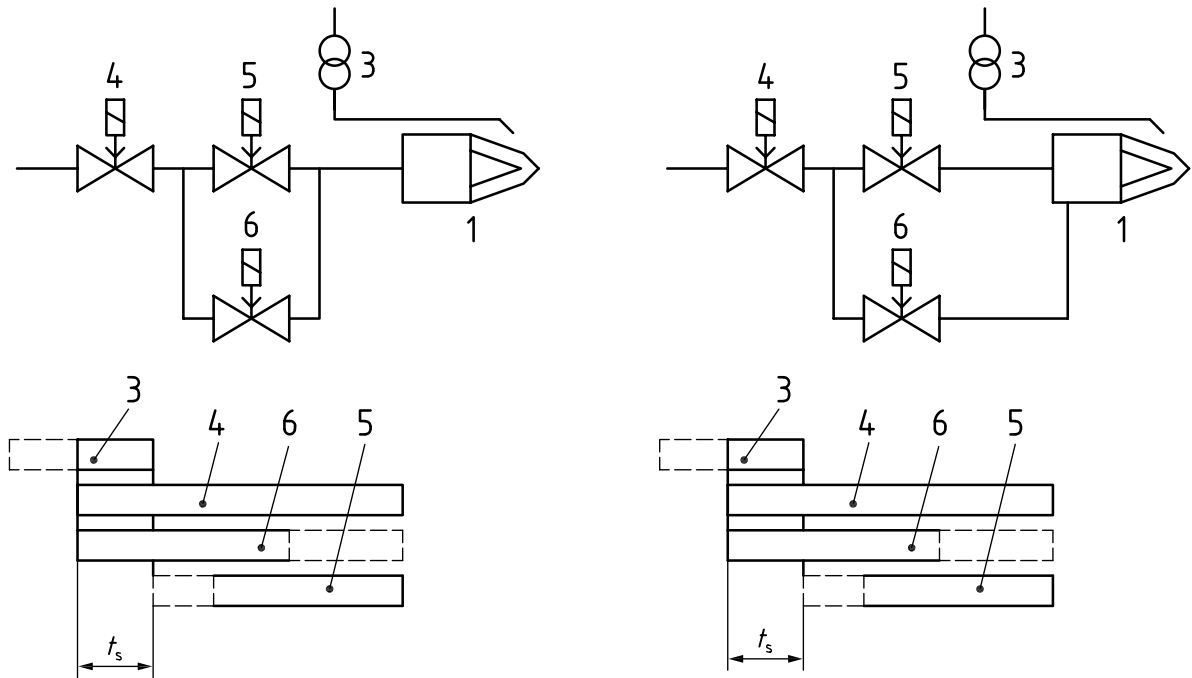

**Key**

- 1 burner
- 3 ignition
- 4 1st shut-off valve
- 5 2nd shut-off valve
- 6 by-pass shut-off valve
- $t_s$  safety time

- 1 burner
- 3 ignition
- 4 1st shut-off valve
- 5 2nd shut-off valve
- 6 by-pass shut-off valve
- $t_s$  safety time

**Figures D.3 and D.4 — Direct main burner ignition at reduced rate with by-pass start gas supply (see Table 3, Column 4)**

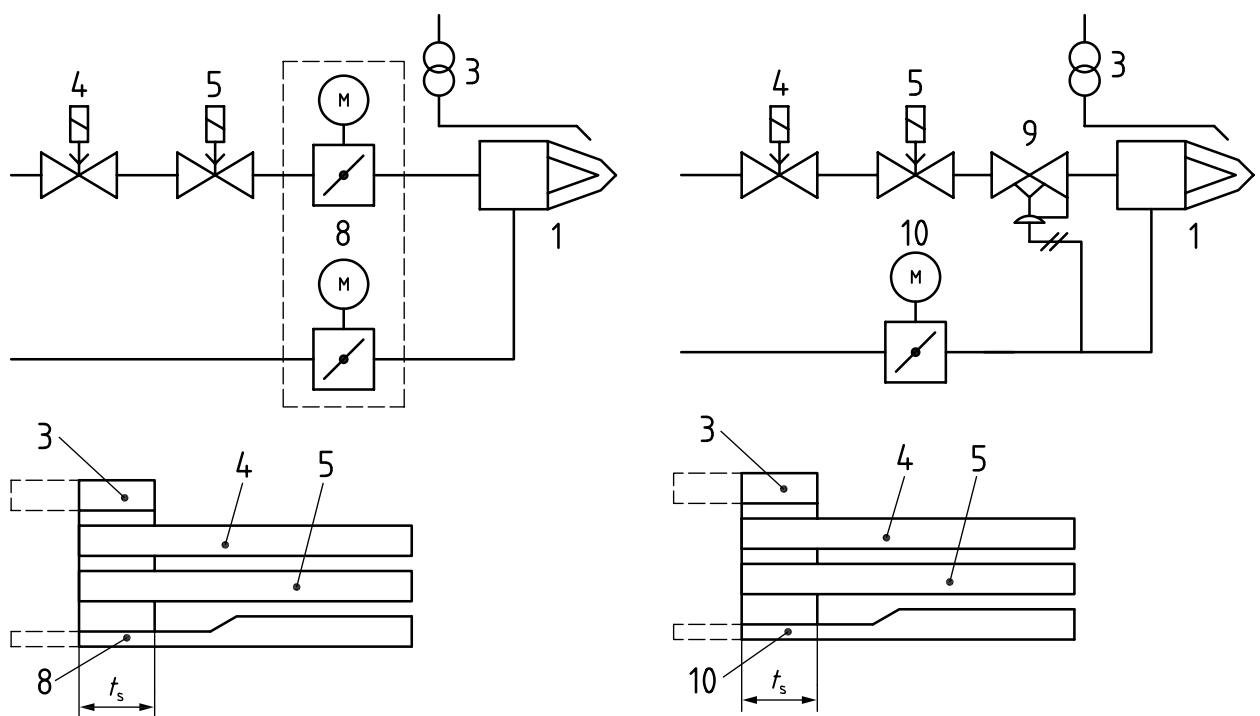

ISO 13577-2:2014(E)

Key

- |       |   |       |                                       |
|-------|---|-------|---------------------------------------|
| 1     | burner  | 1     | burner                                |
| 3     | ignition  | 3     | ignition                              |
| 4     | 1st shut-off valve                              | 4     | 1st shut-off valve                    |
| 5     | 2nd shut-off valve                              | 5     | 2nd shut-off valve                    |
| 8     | electronic air/gas ratio control with motor (M) | 9     | air/gas ratio control (PDCV)          |
| $t_s$ | safety time                                     | 10    | air flow control valve with motor (M) |
|       |   | $t_s$ | safety time                           |

Figures D.5 and D.6 — Direct main burner ignition at reduced rate with limited start gas input (see Table 3, Column 4)

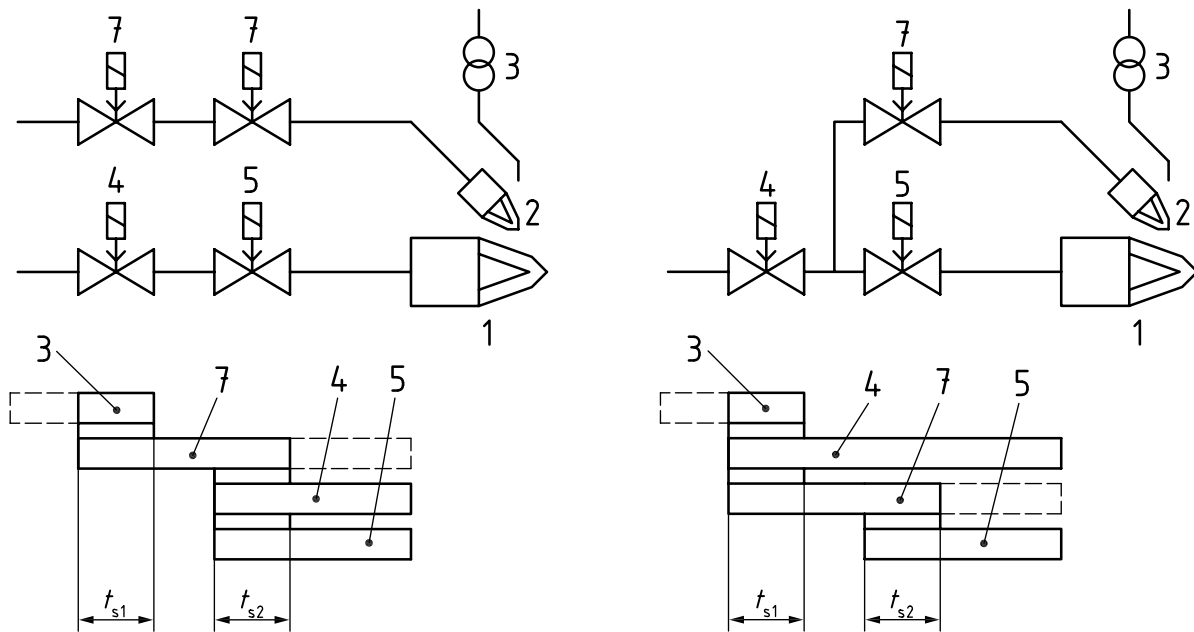

Key

- |          |                             |          |                             |
|----------|-----------------------------|----------|-----------------------------|
| 1        | burner                      | 1        | burner                      |
| 2        | pilot burner                | 2        | pilot burner                |
| 3        | ignition                    | 3        | ignition                    |
| 4        | 1st shut-off valve          | 4        | 1st shut-off valve          |
| 5        | 2nd shut-off valve          | 4        | 2nd shut-off valve          |
| 7        | pilot burner shut-off valve | 7        | pilot burner shut-off valve |
| $t_{s1}$ | safety time 1               | $t_{s1}$ | safety time 1               |
| $t_{s2}$ | safety time 2               | $t_{s2}$ | safety time 2               |

Figures D.7 and D.8 — Main burner ignition with independent pilot burner (see Table 3, Column 5,  $Q_{F \max} \leq 120 \text{ kW}$ )

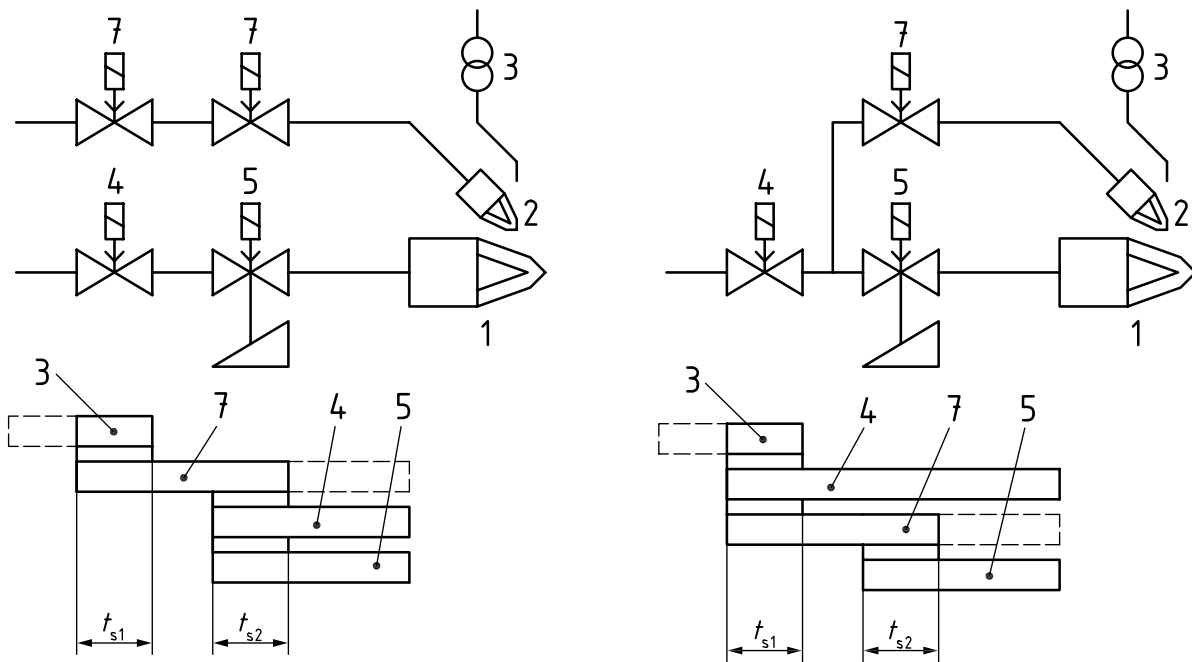

**Key**

- 1 burner
- 2 pilot burner
- 3 ignition
- 4 1st shut-off valve
- 5 2nd shut-off valve
- 7 pilot burner shut-off valve
- $t_{s1}$  safety time 1
- $t_{s2}$  safety time 2

- 1 burner
- 2 pilot burner
- 3 ignition
- 4 1st shut-off valve
- 5 2nd shut-off valve
- 7 pilot burner shut-off valve
- $t_{s1}$  safety time 1
- $t_{s2}$  safety time 2

**Figures D.9 and D.10 — Main burner ignition with independent pilot burner  
(see Table 3, Column 5,  $Q_{F \max} \leq 360$  kW)**

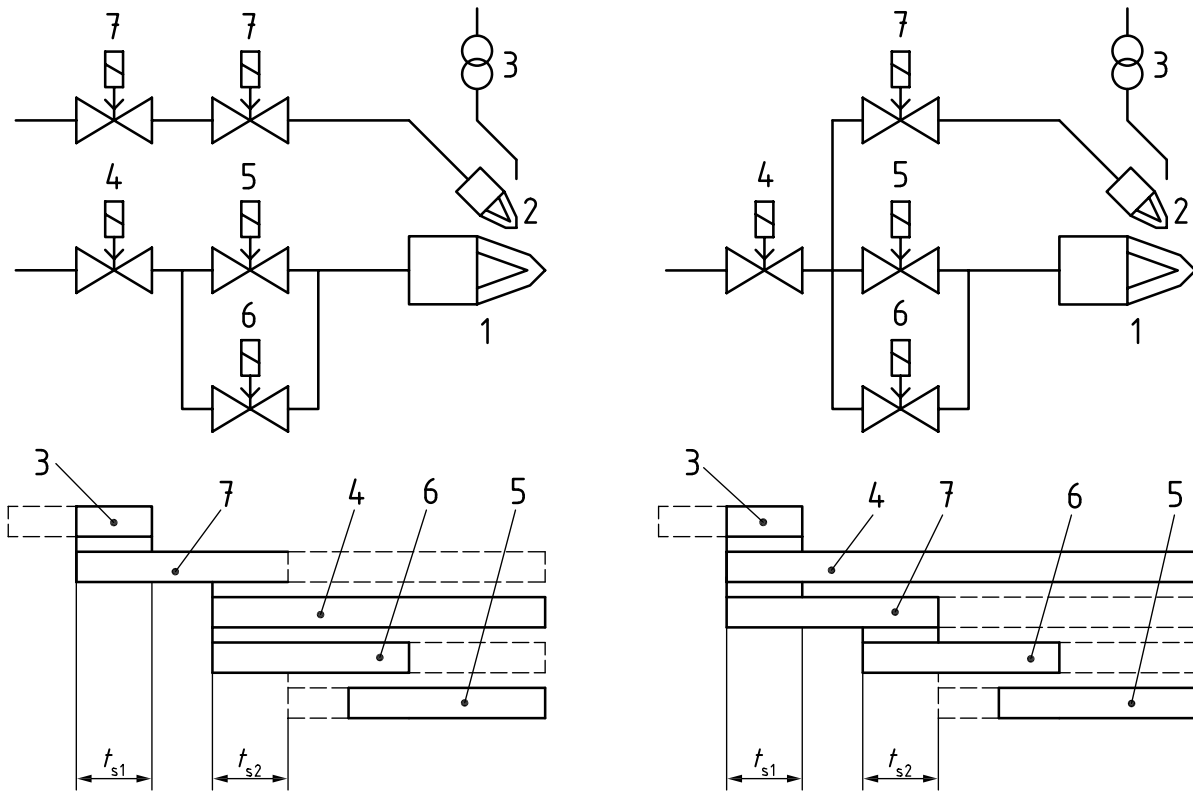

**Key**

- 1 burner
- 2 pilot burner
- 3 ignition
- 4 1st shut-off valve
- 5 2nd shut-off valve
- 6 by-pass shut-off valve
- 7 pilot burner shut-off valve
- $t_{s1}$  safety time 1
- $t_{s2}$  safety time 2

- 1 burner
- 2 pilot burner
- 3 ignition
- 4 1st shut-off valve
- 5 2nd shut-off valve
- 6 by-pass shut-off valve
- 7 pilot burner shut-off valve
- $t_{s1}$  safety time 1
- $t_{s2}$  safety time 2

**Figures D.11 and D.12 — Main burner ignition with independent pilot burner  
(see [Table 3](#), Column 5)**

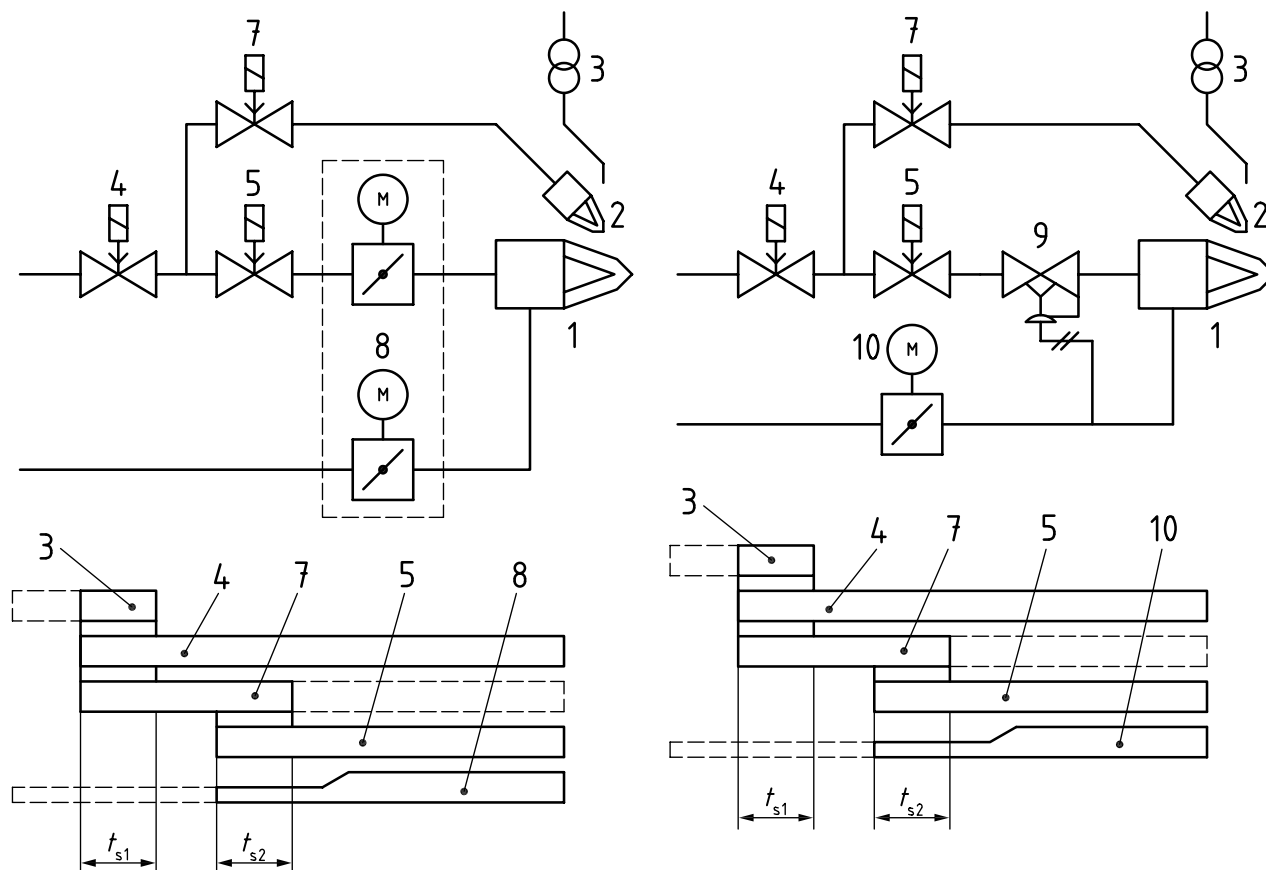

**Key**

- 1 burner
  - 2 pilot burner
  - 3 ignition
  - 4 1st shut-off valve
  - 5 2nd shut-off valve
  - 7 pilot burner shut-off valve
  - 8 electronic air/gas ratio control with motors (M)
- $t_{s1}$  safety time 1  
 $t_{s2}$  safety time 2

- 1 burner
  - 2 pilot burner
  - 3 ignition
  - 4 1st shut-off valve
  - 5 2nd shut-off valve
  - 7 pilot burner shut-off valve
  - 9 air/gas ratio control (PDCV)
  - 10 air flow control valve with motor (M)
- $t_{s1}$  safety time 1  
 $t_{s2}$  safety time 2

**Figures D.13 and D.14 — Main burner ignition with independent pilot burner (see Table 3, Column 5)**

## Annex E (normative)

### Maximum allowed pressure

This part of ISO 13577 covers the pressure hazard of piping forming an integral part of combustion and fuel handling systems of TPE intended to be subjected to a maximum allowable pressure of not more than 50 kPa.

For piping with a maximum allowable pressure of more than 50 kPa, the pressure hazard is covered in the following cases:

- a) gases, liquefied gases, gases dissolved under pressure, vapours and also those liquids whose vapour pressure at the maximum allowable temperature is greater than 50 kPa above normal atmospheric pressure, (101,3 kPa) at the following limits:
  - for Group 1
    - DN 25 and included;
    - $DN \times PS \text{ (kPa)} = 1,0 \times 10^5 \text{ kPa}$  for DN 25 up to 100 and included (see [Figure E.1](#)),
  - for Group 2
    - DN 100 and included;
    - $DN \times PS \text{ (kPa)} = 3,5 \times 10^5 \text{ kPa}$  for DN greater than 100 (See [Figure E.2](#)).
- b) liquids having a vapour pressure at the maximum allowable temperature of not more than 500 kPa above normal atmospheric pressure (101,3 kPa) at the following limits:
  - for Group 1
    - DN 25 and included;
    - $DN \times PS \text{ (kPa)} = 2,0 \times 10^5 \text{ kPa}$  for DN 25 up to 200 and included;
    - $PS \text{ (kPa)} = 1,0 \times 10^3 \text{ kPa}$  for DN greater than 200 (See [Figure E.3](#)),
  - for Group 2
    - DN 200 and included;
    - $PS \text{ (kPa)} = 5,0 \times 10^4 \text{ kPa}$  for DN greater than 200 (See [Figure E.4](#)).

Group 1 comprises the following fluids:

- explosive;
- extremely flammable;
- highly flammable;
- flammable (where the maximum allowable temperature is above flashpoint);
- very toxic;
- toxic;
- oxidizing.

Group 2 comprises all other fluids.

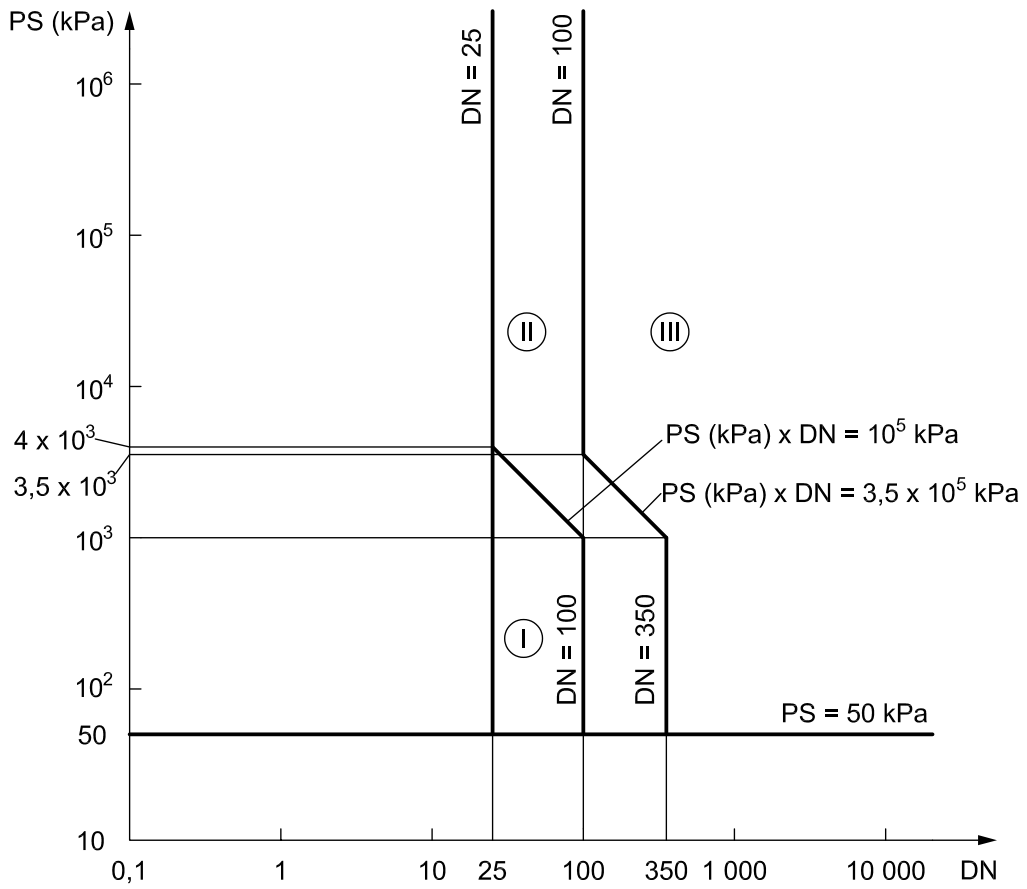

Figure E.1 — Piping referred to clause a) group 1 of Annex E

NOTE References to category 2 and 3 of this annex are mentioned for information only.

## ISO 13577-2:2014(E)

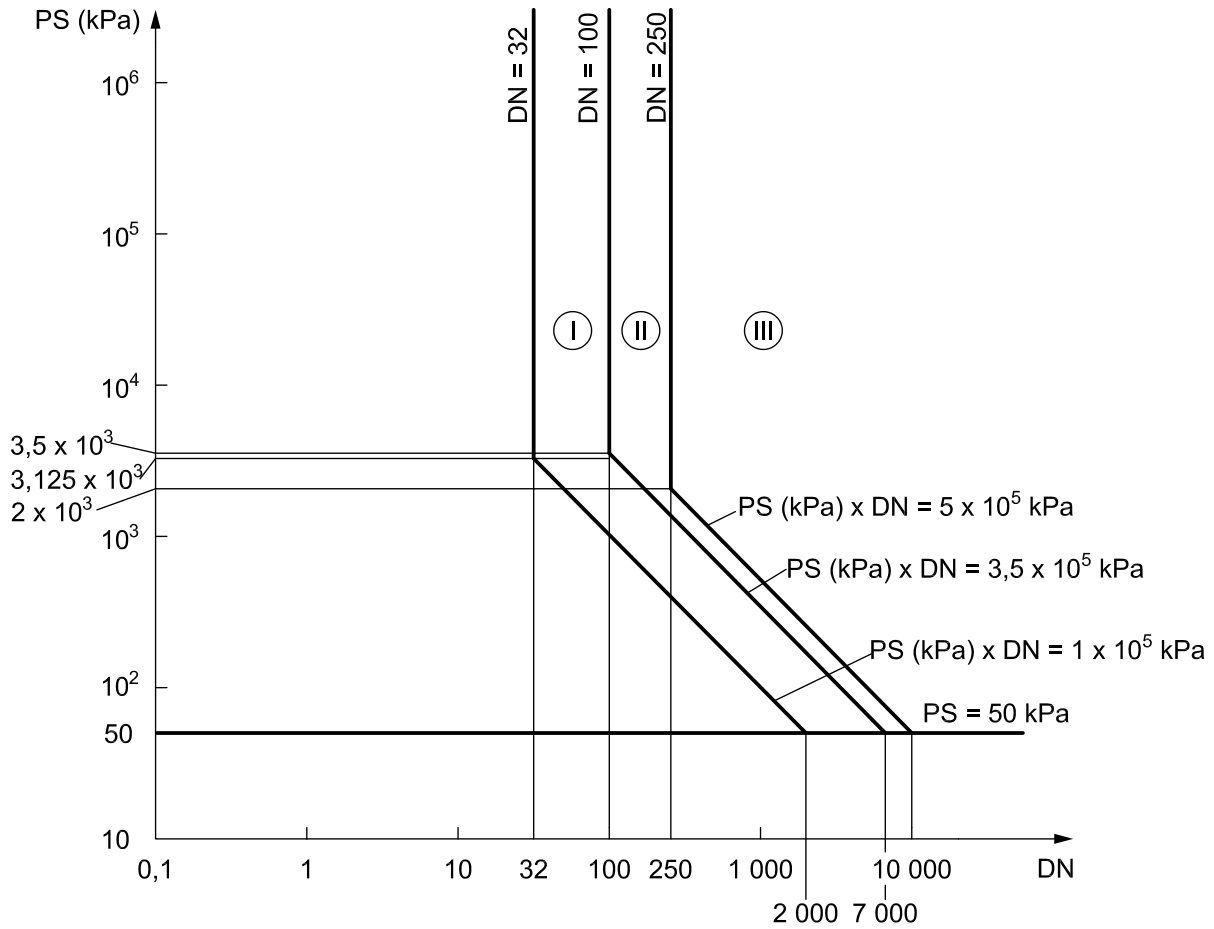

Figure E.2 — Piping referred to clause a) group 2 of [Annex E](#)

NOTE References to category 2 and 3 of this annex are mentioned for information only.

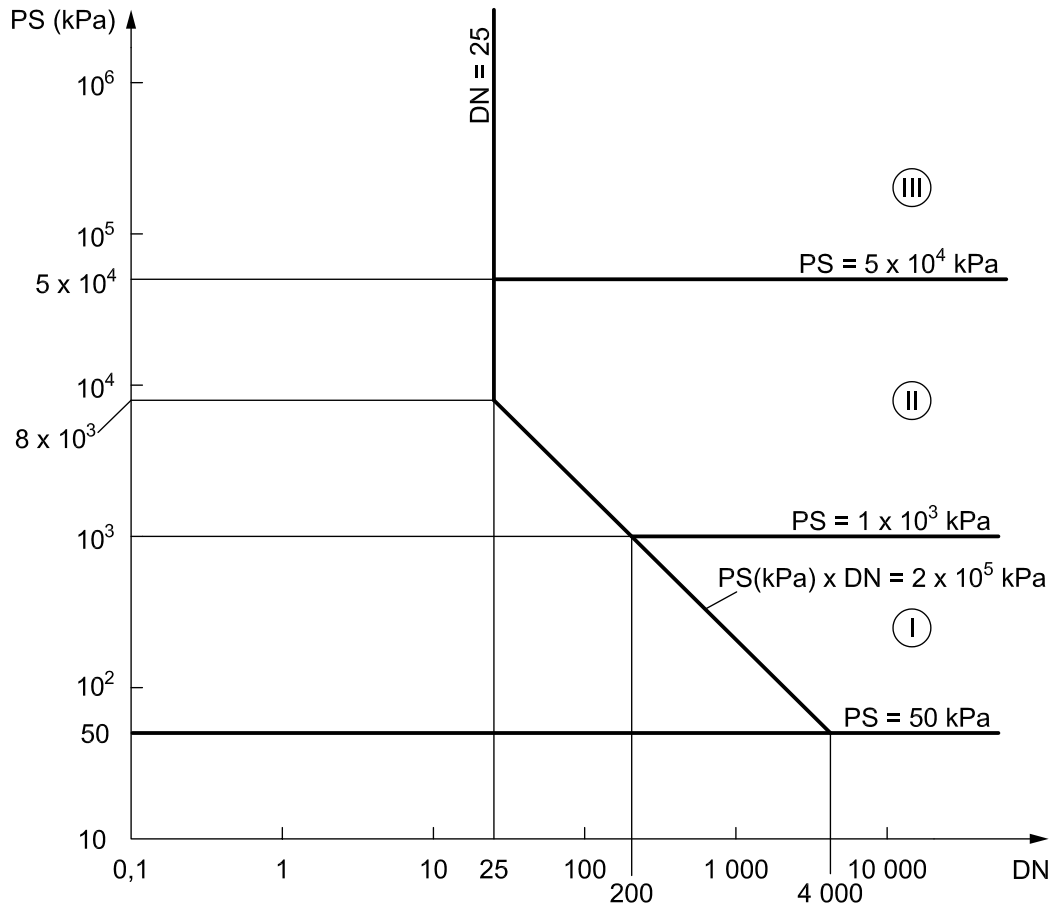

Figure E.3 — Piping referred to clause b) group 1 of Annex E

NOTE References to category 2 and 3 of this annex are mentioned for information only.

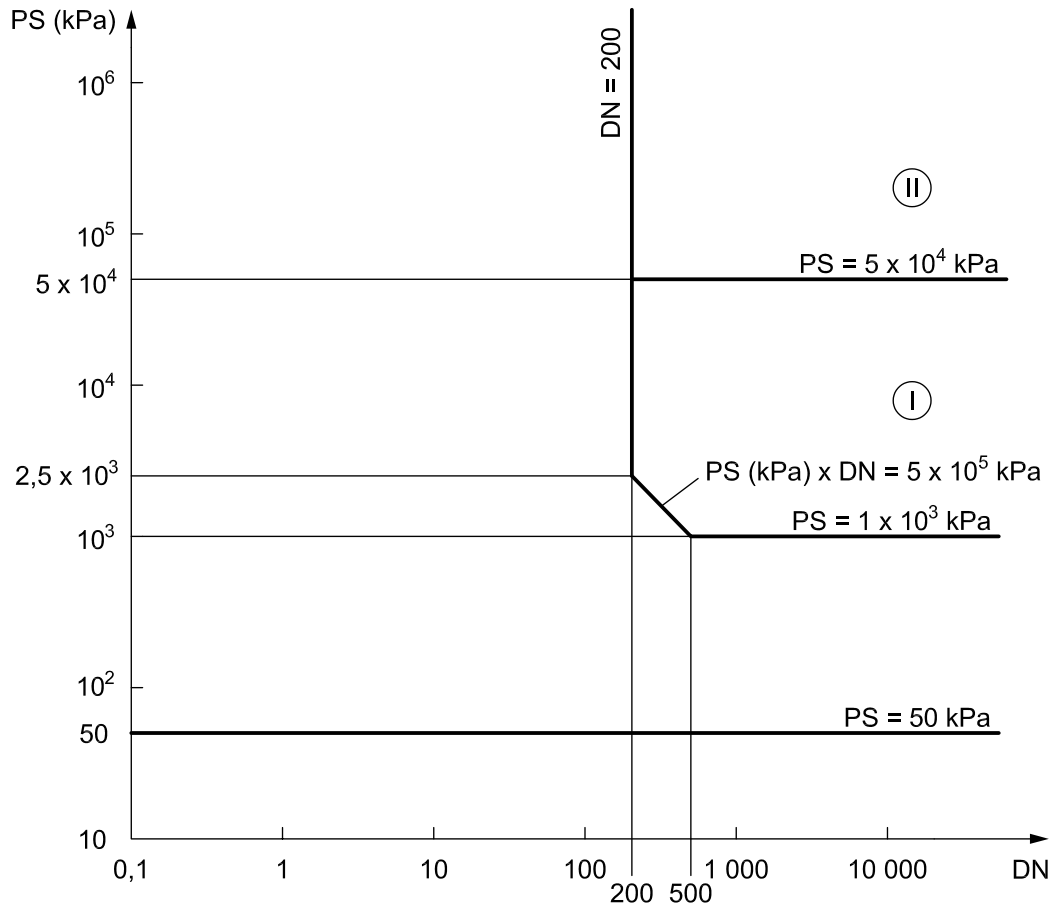

Figure E.4 — Piping referred to clause b) group 2 of [Annex E](#)

NOTE References to category 2 and 3 of this annex are mentioned for information only.

## Annex F (informative)

### Examples for the determination of safety integrity level (SIL) using the risk graph method

Several International Standards may be used for determination of the required safety integrity level (SIL)/performance level (PL). For machinery, IEC 62061 was developed to determine the SIL while IEC 61511 (all parts) was developed to determine the required SIL for process industry. Risk graph methods for determining the SIL are given in both IEC standards. In addition, ISO 13849-1:2006 covers the determination of a performance level PL and also includes a method to determine PL from SIL (ISO 13849-1:2006, Table 4).

[Table F.1](#) shows an example of SIL/PL determination according to IEC 62061/ISO 13849-1:2006, Table 4. This SIL determination is done according to IEC 62061:2005, Figure A.3. The PL is determined in accordance with Table 4 in ISO 13849-1:2006 which shows the relationship between PL and SIL.

[Table F.2](#) shows an example of SIL determination according to the second edition of IEC 61511 (all parts)<sup>1)</sup>.

The values given in [Table F.1](#) and [Table F.2](#) refer to typical TPE. The required SIL/PL levels might vary dependent on the individual risk assessment.

---

1) To be published.

**Table F.1 — Example of SIL/PL determination according to IEC 62061 and ISO 13849-1:2006, Table 4**

Document No.: Part of:		Risk assessment and safety measures								
Project: Example of typical SIL determination	Pre risk assessment Intermediate risk assessment Follow up risk assessment									
Issued by:										
Date:										
Revision: 2012/12/13										
Black area = Safety measures required Grey area = Safety measures recommended										
Consequences	Severity Se	Class Cl				Frequency and duration, Fr	Probability of hazard event, Pr	Avoidance Av		
		3 - 4	5 - 7	8 - 10	11 - 13				14 - 15	
Death, losing an eye or arm	4	SIL 2	SIL 2	SIL 2	SIL 3	SIL 3	5	Very high	5	
Permanent, losing fingers	3		OM	SIL 1	SIL 2	SIL 3	5	Likely	4	
Reversible, medical attention	2			OM	SIL 1	SIL 2	> 1day - < = 2weeks	Possible	3	Impossible
Reversible, first aid	1				OM	SIL 1	> 2weeks - < = 1 year	Rarely	2	Possible
							> 1 year	Negligible	1	Likely

Table F.1 — (continued)

SRCF No.	Hazardous event Description	Safety Related Control Function (SRCF) Description	Consequences		Probability of occurrence			Class Cl	Integrity		Comments
			Se	Fr	Pr	Av	SIL		PL		
01	Fuel gas supply pressure too low	Pressure switch or pressure transmitter is monitoring the gas pressure, and in combination with the logic circuit brings the plant to a safe state if the pressure decreases below a safe level.	4	5	2	1	8	2	d	<a href="#">4.2.2.4</a> : Low gas protection Hazards: explosion, poisoning, CO caused by excess air operation of the burner	
02	Fuel gas pressure too high, failure of upstream regulator	Pressure switch or pressure transmitter is monitoring the gas pressure, and in combination with the logic circuit brings the plant to a safe state if the pressure rises above a safe level.	4	5	2	3	10	2	d	<a href="#">4.2.2.5</a> : High gas protection, Hazards: explosion, fire, poisoning, incomplete combustion	
03	Liquid fuel pressure too high	Pressure switch or pressure transmitter is monitoring the liquid pressure, and in combination with the logic circuit brings the plant to a safe state if the pressure rises above a safe level.	4	5	2	3	10	2	d	<a href="#">4.3.2.6</a> : Liquid fuel pressure protection, Hazards: explosion, fire, poisoning, incomplete combustion	
04	Liquid fuel pressure too low	Pressure switch or pressure transmitter is monitoring the gas pressure, and in combination with the logic circuit brings the plant to a safe state if the pressure decreases below a safe level.	4	5	2	3	10	2	d	<a href="#">4.3.2.6</a> : Liquid fuel pressure protection, Hazards: bad atomizing, soot, bad combustion, CO caused by excess air operation (light oil)	
05	Liquid fuel temperature too high	Thermostat or temperature transmitter is monitoring the liquid temperature, and in combination with the logic circuit brings the plant to a safe state if the temperature rises above a safe level.	4	5	2	3	10	2	d	<a href="#">4.3.2.7</a> : Liquid fuel temperature protection, Hazards: explosion, fire, poisoning, incomplete combustion	

Table F.1 (continued)

SRCF No.	Hazardous event Description	Safety Related Control Function (SRCF) Description	Consequences		Probability of occurrence			Class Cl	Integrity		Comments
			Se	Fr	Pr	Av	SIL		PL		
06	Liquid fuel temperature too low	Thermostat or temperature transmitter is monitoring the liquid temperature, and in combination with the logic circuit brings the plant to a safe state if the temperature decreases below a safe level.	2	5	2	3	10	OM	-	<a href="#">4.3.2.7</a> : Liquid fuel temperature protection, Hazards: bad atomizing, soot, bad combustion	
07	Atomizing fluid pressure outside safe operating range	A pressure sensing device is monitoring the atomizing fluid pressure, and in combination with the logic circuit brings the plant into a safe state if the pressure is outside the tolerable pressure range	4	5	2	1	8	2	d	<a href="#">4.3.2.8</a> : Automatic shut-off valves Hazard: explosion, fire, bad atomizing, bad combustion	
08	Failure of heat transfer fluid	Flow, pressure, temperature, position or level sensors in combination with a logic system are detecting if the heat transfer fluid is sufficient. If not the plant is brought into a safe state.	4	5	2	3	10	2	d	<a href="#">4.2.2.6/4.3.2.8</a> : Automatic shut-off valves Hazard: overheating, poisoning, fire	
09	Failure of power supply and/or other utilities used for operating valves and other equipment essential for bringing the plant into a safe state (e.g. compressed air, steam)	A sensor for pressure, flow, voltage etc. in combination with a logic bringing the plant into a safe state.	4	5	2	3	10	2	d	<a href="#">4.2.2.6/4.3.2.8</a> : Automatic shut-off valves, Hazard: explosion, fire, poisoning.	
10	Plant temperature exceeding the maximum allowable operating temperature	A temperature sensor in combination with a logic system is monitoring the process temperature. If the temperature rises above the safe level, it shall be brought into a safe state.	4	5	2	3	10	2	d	<a href="#">4.2.2.6/4.3.2.8</a> : Automatic shut-off valves, Hazard: fire, mechanical break down, injuries from hot parts.	

Table F.1 (continued)

SRCF No.	Hazardous event Description	Safety Related Control Function (SRCF) Description	Consequences		Probability of occurrence			Class	Integrity		Comments
			Se	Fr	Pr	Av	CI		SIL	PL	
11	Failure of valve proving	A pressure sensing device or position device combined with a logic system is detecting if the gas system has a tolerable low leakage. If not the start is prevented.	4	5	1	1	7	2	d	<a href="#">4.2.2.7</a> : Valve proving, Hazards: explosion, explosive atmosphere	
12	Combustion air pressure / flow too low	Pressure switch, pressure transmitter or flow meter is monitoring the air pressure / flow, and in combination with the logic circuit brings the plant to a safe state if the pressure / flow decreases below a safe level.	4	5	2	3	10	2	d	<a href="#">4.2.3.2/4.3.3.2</a> : Air flow and pressure detectors, Hazards: explosion, fire, poisoning, incomplete combustion	
13	Air / gas ratio outside safe operating range	The correct air / gas ratio is controlled by mechanical, pneumatic or electric systems. The electric ratio sensor combined with a logic system shall bring the ratio to a safe level.	4	5	4	5	14	3	e	<a href="#">4.2.3.3/4.3.3.3</a> : Air/fuel ratio, Hazard: explosion, fire, poisoning.	
14	Combustion chamber pressure too high, failure of flue gas venting	A pressure sensing device combined with a logic system is detecting if the combustion chamber pressure leads to a harmful flue gas escape and brings the plant into a safe state.	3	5	2	3	10	1	c	<a href="#">4.2.5.5/4.3.5.5</a> : Flue gas venting, Hazard: poisoning, inhalation of harmful fluids.	
15	Flame failure	Each burner is supervised by a flame sensing device, which in combination with a logic system is bringing the burner or the plant into a safe state if the flame extinguish unwanted.	4	5	4	5	14	3	e	<a href="#">4.2.6/4.3.6</a> : Automatic burner control system, Hazards: explosion, fire	

Table F.1 (continued)

SRCF No.	Hazardous event Description	Safety Related Control Function (SRCF) Description	Consequences		Probability of occurrence			Class Cl	Integrity		Comments
			Se	Fr	Pr	Av	SIL		PL		
16	Temperature monitoring for high temperature operation	A temperature sensor combined with a logic system is detecting when the limit for high temperature equipment has been reached. Only above this limit the high temperature equipment functions are released.	4	5	4	5	14	3	e	<a href="#">4.2.6.3/4.3.6.3</a> : High temperature equipment, Hazard: explosion, fire	
17	Air flow too low during purge	Flow meter, differential pressure switch or transmitter is monitoring the air flow, and in combination with the logic circuit brings the plant to a safe state if the flow decreases below a safe level.	4	5	2	3	10	2	d	<a href="#">4.2.7.1/4.3.7.1</a> : Pre-purge, Hazards: explosion, insufficient purging	
18	Start fuel flow rate too high	The position or state of a limiting device ensuring a safe burner ignition is monitored for correct position. If not start is prevented.	3	5	2	1	8	1	c	<a href="#">4.2.7.2/4.3.7.2</a> : Start fuel flow rate, Hazard: hard or failed burner start with possible high impact of the construction.	

**Table F.2 — Example of SIL determination according to IEC 61511 (Ed. 2)**

Project: Example of typical SIL determination Issued by: SIF: Date: Plant: Revision: Risk:		Process: SIF: Plant: Risk:								
Consequence parameter	Risk graph matrix		Occupancy parameter Frequency of human presence in the hazardous zone. Credit for limited occupancy must not have been taken choosing consequence categories!	Avoidance of parameter Probability of avoiding the hazardous event <b>if the SIF fails on demand</b> . Implies <b>independent</b> facilities provided to "shut-down" so hazard can be avoided or enable all persons to escape to a safe area.  Conditions to be fulfilled: <ul style="list-style-type: none"> <li>•Facilities to alert operator that the SIS has failed</li> <li>•Independent facilities to bring process to safe state</li> <li>•Time between operator alert and hazardous event &gt; 1h</li> </ul>	Demand rate parameter					
	Severity level	Likelihood sum (F+P+W)			Estimated SIF demand rate	W				
C <sub>F</sub>	C	1-2	3-4	5-6	7-8	9-10	11-12	W <sub>9</sub>	> 1/year	9
	F	a	SIL 1	SIL 2	SIL 3	SIL 4	b	W <sub>8</sub>	Frequent	8
C <sub>E</sub>	E	OK	a	SIL 1	SIL 2	SIL 3	SIL 4	W <sub>7</sub>	Likely	7
C <sub>b</sub>	D	OK	OK	a	SIL 1	SIL 2	SIL 3	W <sub>6</sub>	Probable	6
C <sub>c</sub>	C	OK	OK	OK	a	SIL 1	SIL 2	W <sub>5</sub>	Occasional	5
C <sub>B</sub>	B	OK	OK	OK	OK	a	SIL 1	W <sub>4</sub>	Remote	4
C <sub>A</sub>	A	OK	OK	OK	OK	OK	a	W <sub>3</sub>	Improbable	3
								W <sub>2</sub>	Incredible	2
								W <sub>1</sub>	Inconceivable	1

Table F.2 — (continued)

SIF- No.	Hazardous event Description	Safety Instrumented Function (SIF) Description	Consequences			Influence		Demand W	Likelihood		Integrity SIL SIL	Hazard description and comments
			Harm	C	F	P	Sum					
01	Fuel gas supply pressure too low	Pressure switch or pressure transmitter is monitoring the gas pressure, and in combination with the logic circuit brings the plant to a safe state if the pressure decreases below a safe level.	H	D	2	1	6	9	2	2	4.2.2.4: Low gas protection, Hazards: explosion, poisoning, CO caused by excess air operation of the burner	
			E	B	1	1		8	-			
			F	E	1	1		8	2			
02	Fuel gas pressure too high, failure of upstream regulator	Pressure switch or pressure transmitter is monitoring the gas pressure, and in combination with the logic circuit brings the plant to a safe state if the pressure rises above a safe level.	H	D	2	1	6	9	2	2	4.2.2.5: High gas protection, Hazards: explosion, fire, poisoning, incomplete combustion	
			E	B	1	1		8	-			
			F	E	1	1		8	2			
03	Liquid fuel pressure too high	Pressure switch or pressure transmitter is monitoring the liquid pressure, and in combination with the logic circuit brings the plant to a safe state if the pressure rises above a safe level.	H	D	2	1	6	9	2	2	4.3.2.6: Liquid fuel pressure protection, Hazards: explosion, fire, poisoning, incomplete combustion	
			E	B	1	1		8	-			
			F	E	1	1		8	2			
04	Liquid fuel pressure too low	Pressure switch or pressure transmitter is monitoring the gas pressure, and in combination with the logic circuit brings the plant to a safe state if the pressure decreases below a safe level.	H	D	2	1	6	9	2	2	4.3.2.6: Liquid fuel pressure protection, Hazards: bad atomizing, soot, bad combustion, CO caused by excess air operation (light oil)	
			E	B	1	1		8	-			
			F	E	1	1		8	2			
05	Liquid fuel temperature too high	Thermostat or temperature transmitter is monitoring the liquid temperature, and in combination with the logic circuit brings the plant to a safe state if the temperature rises above a safe level.	H	D	2	1	6	9	2	2	4.3.2.7: Liquid fuel temperature protection, Hazards: explosion, fire, poisoning, incomplete combustion	
			E	B	1	1		8	-			
			F	E	1	1		8	2			

Table F.2 (continued)

SIF- No.	Hazardous event Description	Safety Instrumented Function (SIF) Description	Consequences		Influence		Demand W	Likeli- hood Sum	Integrity		Hazard description and comments
			Harm	C	F	P			SIL	SIL	
06	Liquid fuel temperature too low	Thermostat or temperature transmitter is monitoring the liquid temperature, and in combination with the logic circuit brings the plant to a safe state if the temperature decreases below a safe level.	H	B	2	1	6	9	a	0	<a href="#">4.3.2.7</a> : Liquid fuel temperature protection, Hazards: bad atomizing, soot, bad combustion
			E	C				8	a		
			F	B	1	1		8	-		
07	Atomizing fluid pressure outside safe operating range	A pressure sensing device is monitoring the atomizing fluid pressure, and in combination with the logic circuit brings the plant into a safe state if the pressure is outside the tolerable pressure range	H	D	2	0	6	8	1	2	<a href="#">4.3.2.8</a> : Automatic shut-off valves, Hazard: explosion, fire, bad atomizing, bad combustion
			E	B				7	-		
			F	E	1	0		7	2		
08	Failure of heat transfer fluid	Flow, pressure, temperature, position or level sensors in combination with a logic system are detecting if the heat transfer fluid is sufficient. If not the plant is brought into a safe state.	H	D	2	1	6	9	2	2	<a href="#">4.2.2.6/4.3.2.8</a> : Automatic shut-off valves, Hazard: overheating, poisoning, fire
			E	B				8	-		
			F	D	1	1		8	1		
09	Failure of power supply and/or other utilities used for operating valves and other equipment essential for bringing the plant into a safe state (e.g. compressed air, steam)	A sensor for pressure, flow, voltage etc. in combination with a logic bringing the plant into a safe state.	H	D	2	1	6	9	2	2	<a href="#">4.2.2.6/4.3.2.8</a> : Automatic shut-off valves, Hazard: explosion, fire, poisoning.
			E	B				8	-		
			F	E	1	1		8	2		
10	Plant temperature exceeding the maximum allowable operating temperature	A temperature sensor in combination with a logic system is monitoring the process temperature. If the temperature rises above the safe level, it shall be brought into a safe state.	H	D	2	1	6	9	2	2	<a href="#">4.2.2.6/4.3.2.8</a> : Automatic shut-off valves, Hazard: fire, mechanical break down, injures from hot parts.
			E	B				8	-		
			F	D	1	1		8	2		

Table F.2 (continued)

SIF- No.	Hazardous event Description	Safety Instrumented Function (SIF) Description	Consequences			Influence		Demand W	Likeli- hood Sum	Integrity		Hazard description and comments
			Harm	C	F	P	SIL			SIL		
11	Failure of valve proving	A pressure sensing device or position device combined with a logic system is detecting if the gas system has a tolerable low leakage. If not the start is prevented.	H	D	2	1	6	8	9	2	2	4.2.2.7: Valve proving, Hazards: explosion, explosive atmosphere
			E	B					-			
			F	E	1	1			2			
12	Combustion air pressure/flow too low	Pressure switch, pressure transmitter or flow meter is monitoring the air pressure / flow, and in combination with the logic circuit brings the plant to a safe state if the pressure / flow decreases below a safe level.	H	D	2	1	6	8	9	2	2	4.2.3.2/4.3.3.2: Air flow and pressure detectors, Hazards: explosion, fire, poisoning, incomplete combustion
			E	B					-			
			F	E	1	1			2			
13	Air/gas ratio outside safe operating range	The correct air / gas ratio is controlled by mechanical, pneumatic or electric systems. The electric ratio sensor combined with a logic system shall bring the ratio to a safe level.	H	D	2	1	7	9	10	2	3	4.2.3.3/4.3.3.3: Air/fuel ratio, Hazard: explosion, fire, poisoning.
			E	B					a			
			F	E	1	1			3			
14	Combustion chamber pressure too high, failure of flue gas venting	A pressure sensing device combined with a logic system is detecting if the combustion chamber pressure leads to a harmful flue gas escape and brings the plant into a safe state.	H	D	2	0	6	7	8	1	1	4.2.5.5/4.3.5.5: Flue gas venting, Hazard: poisoning, inhalation of harmful fluids.
			E	A					-			
			F	D	1	0			1			
15	Flame failure	Each burner is supervised by a flame sensing device, which in combination with a logic system is bringing the burner or the plant into a safe state if the flame extinguish unwanted.	H	D	2	1	8	10	11	3	3	4.2.6/4.3.6: Automatic burner control system, Hazards: explosion, fire
			E	A					-			
			F	E	1	1			3			

Table F.2 (continued)

SIF- No.	Hazardous event Description	Safety Instrumented Function (SIF) Description	Consequences		Influence		Demand	Likeli- hood Sum	Integrity		Hazard description and comments
			Harm	C	F	P			W	SIL	
16	Temperature monitoring for high temperature operation	A temperature sensor combined with a logic system is detecting when the limit for high temperature equipment has been reached. Only above this limit the high temperature equipment functions are released.	H	D	2	1	7	10	2	3	4.2.6.3/4.3.6.3: High temperature equipment, Hazard: explosion, fire
			E	B				9	a		
			F	E	1	1		9	3		
17	Air flow too low during purge	Flow meter, differential pressure switch or transmitter is monitoring the air flow, and in combination with the logic circuit brings the plant to a safe state if the flow decreases below a safe level.	H	D	2	1	6	9	2	2	4.2.7.1/4.3.7.1: Pre-purge, Hazards: explosion, insufficient purging
			E	B				8	-		
			F	E	1	1		8	2		
18	Start fuel flow rate too high	The position or state of a limiting device ensuring a safe burner ignition is monitored for correct position. If not start is prevented.	H	C	2	1	7	10	1	1	4.2.7.2/4.3.7.2: Start fuel flow rate, Hazard: hard or failed burner start with possible high impact of the construction.
			E	A				9	-		
			F	C	1	1		9	1		

## Annex G (normative)

### Requirements specific to Japan

#### G.1 General

Only those provisions of this part of ISO 13577 that are affected by requirements specific to Japan have been identified in this annex, numbered correspondingly to the respective subclauses in the main body of the standard.

The requirements of this annex shall ensure a level of safety at least equivalent to that provided by the requirements in the main body of this part of ISO 13577.

#### G.2 Background

In addition to the safety requirements specified in this part of ISO 13577, at least information in regard to the following laws and regulations are required to be prepared when combustion and fuel handling systems which this part of ISO 13577 covers are to be designed, manufactured and commissioned:

- Industrial Safety and Health Law;
- High Pressure Gas Safety Law;
- Air Pollution Control Act.

For this reason, in addition to the requirements specified in this part of ISO 13577:

- matters concerning NO<sub>x</sub> and CO shall comply with Air Pollution Control Act;
- matters concerning fuel supplied at 1 MPa or more shall comply with High Pressure Gas Safety Act;
- matters concerning general safety which is not covered by this part of ISO 13577 shall comply with the relevant regulations specified in Industrial Safety and Health Act.

In addition, regional safety requirements for combustion and fuel handling systems of TPE used in Japan are specified in JIS B 8415:2008.

Those specified in this part of [Annex G](#) are the additional requirements or test methods based on JIS B 8415:2008 for equipment intended to be used in Japan. Numbers in the brackets added to the each clause title correspond to the clause in the main body text.

#### G.3 References

For dated references only the edition cited applies. For undated references the latest edition of the referenced document (including any amendments) applies.

ISO 23550, *Safety and control devices for gas burners and gas-burning appliances – General requirements*

JIS B 2220, *Steel pipe flanges*

JIS B 231,2 *Steel butt-welding pipe fittings*

JIS G 3452, *Carbon steel pipes for ordinary piping*

JIS G 3454, *Carbon steel pipes for pressure service*

JIS G 3455, *Carbon steel pipes for high pressure service*  
 JIS G 3456, *Carbon steel pipes for high temperature service*  
 JIS G 3457, *Arc welded carbon steel pipes*  
 JIS G 3458, *Alloy steel pipes*  
 JIS G 3459, *Stainless steel pipes*  
 JIS G 3460, *Steel pipes for low temperature service*  
 JIS G 3461, *Carbon steel boiler and heat exchanger tubes*  
 JIS G 3462, *Alloy steel boiler and heat exchanger tubes*  
 JIS G 3463, *Stainless steel boiler and heat exchanger tubes*  
 JIS H 3300, *Copper and copper alloy seamless pipes and tubes*  
 JIS H 3401, *Pipe fittings of copper and copper alloys*  
 JIS K 6774, *Polyethylene pipes for the supply of gaseous fuels*  
 JIS B 8415, *General Safety Code for Industrial Combustion Furnaces*

## G.4 Requirements

### G.4.2.1.1 Pipework - General

*Additional to [4.2.1.1](#)*

Fuel gas pipes shall be as specified in JIS G 3452; JIS G 3454; JIS G 3455; JIS G 3456; JIS G 3457; JIS G 3458; JIS G 3459; JIS G 3460; JIS G 3461; JIS G 3462; JIS G 3463; JIS K 6774; and JIS H 3300, as applicable.

However, pipes to JIS G 3458 shall be used only for buried portions of the piping under pressures of less than 1,6 MPa; those to JIS G 3452, only for buried portions under pressures of less than 1,0 MPa; those to JIS K 6774, only for buried portions under pressures of less than 0,3 MPa; and those to JIS H 3300, only exposed portions under pressures of less than 0,1 MPa.

Any flexible tubes not specified in this clause may be used only if they withstand the maximum operating pressure and temperature involved.

### G.4.2.1.2 Connections

*Additional to [4.2.1.2](#)*

Any steel pipes with a nominal diameter of not more than 20A for use under a maximum operating pressure of not more than 0,1 MPa may be connected using compression fittings.

Any copper or copper alloy seamless pipes shall be connected in accordance with JIS H 3401, and such seamless pipes with a nominal diameter of 20A or less for use under a pressure of 0,01 MPa or less may be connected using flared or compression fittings.

### G.4.2.2.6 Automatic shut-off valves

*Additional to [4.2.2.6](#)*

In regenerative burner systems, durability test for the valves should be done with more than 2 million times of motion. The test shall be in accordance with ISO 23550.

**ISO 13577-2:2014(E)**

It is recommended that relays that are used for changeover of the valves have mechanical durability of 10 million times or more and electrical durability of 2 million times or more.

**G.4.2.2.7 Valve proving**

*Additional to [4.2.2.7](#)*

Manual valve tightness check shall be carried out as the following and [Figure G.1](#) at least once a year.

- 1) Pressurize between SSV 2 and V 2 and measure the pressure change. Back pressure resistance of automatic shut of valves shall be taken into account.
- 2) Open V 1 while keeping SSV 2 shut. Then by opening SSV 1 or connecting TV 1 and TV 2 with a rubber tube, pressurize the upstream of SSV 2.
- 3) Open V 2 to ventilate the downstream of SSV 2 to the atmospheric pressure. Then close V 2 and connect another rubber tube at TV 3. Submerge the other tip of the tube into the water filled in a basin/beaker at about 10mm depth and open TV 3 to observe if bubbles emerge. When bubbling continues at the tip of the tube, treatment such as repair or replacement of the valve shall be taken. The precise measurement of the leak rate can be performed by collecting the bubbles in a measuring cylinder filled with water in a certain period of time measured with a stop-watch.
- 4) Same procedure is applied to check if there is a leakage in SSV 1 arranged at upstream of SSV 2.
- 5) When the test is done for three valves or more, the same test method shall be applied starting from the valve placed at the most downstream position.
- 6) When fuel gas pressure cannot be used for the test (e.g. central pipework for low cycling applications, see [Figure C.4](#)), supply high pressure air from each check port just upstream of the examined automatic shut-off valve.
- 7) The leak rate shall be in accordance with the value specified in ISO 23550:2011, 7.2.1.

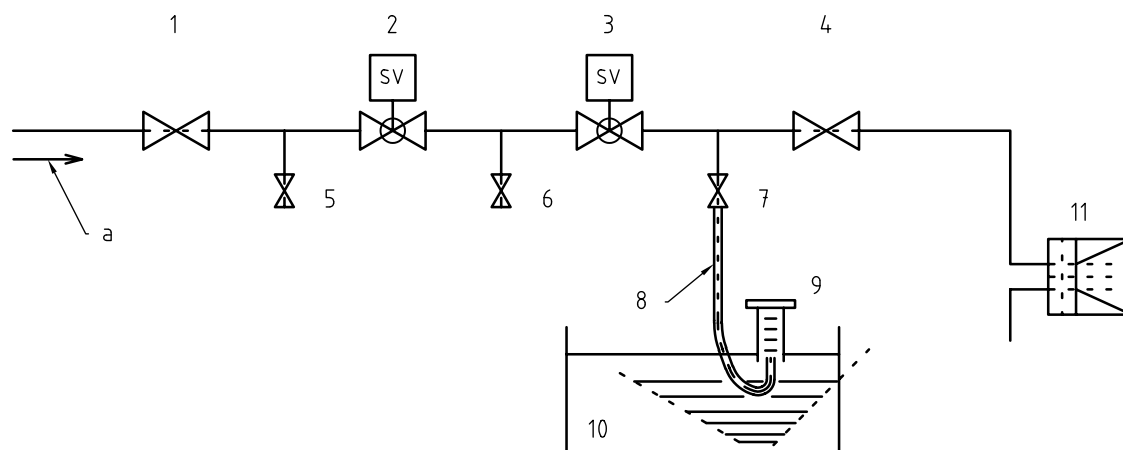

### Key

- 1 burner manual shut-off valve 1 (V1)
- 2 automatic shut-off valve 1 (SSV1)
- 3 automatic shut-off valve 2 (SSV2)
- 4 burner manual shut-off valve 2 (V2)
- 5 test valve 1 (TV1)
- 6 test valve 2 (TV2)
- 7 test valve 3 (TV3)
- 8 flexible hose
- 9 measuring cylinder
- 10 water vessel
- 11 burner
- a Fuel gas flow direction.

**Figure G.1 — In piping diagram for valve tightness check**

Simultaneous closure of three automatic shut-off valves may be used as an alternative to valve proving by an automatic system as specified in [4.2.2.7](#).

Ball valves in accordance with ISO 23551-1 with closed position indicator (CPI) may be used as a part of the automatic system for proving closure of the valves.

#### G.4.2.7.1 Pre-purging of the combustion chamber

*Replaces paragraphs 4, 8 and 9 of [4.2.7.1](#)*

The case the pre-purge may be omitted is limited to the following cases:

- a) when the combustion chamber is proved to be at a temperature above 750 °C (as defined for high temperature equipment);
- b) in a multiple-burner system, one or more burners are burning in the common combustion chamber or the combustion zone;
- c) when starting burner after shutdown for control reason and;
  - 1) a pilot burner equipped with a dedicated flame safeguard is burning continuously or
  - 2) in a pulse combustion system with a specifically equipped ignition source, a flame supervisor dedicated to the main burner is equipped or
  - 3) the furnace atmosphere is proven to be less than 25 % of the lower explosion limit or

**ISO 13577-2:2014(E)**

- 4) the radiant tube is metallic, resistant to explosion, and is equipped with a specifically equipped ignition source.

**G.4.2.7.6 Safety time**

*Replaces the 5th paragraph of [4.2.7.6](#)*

Safety time may differ from those given in [Table 3](#) provided the safety of the TPE is not compromised (e.g. LFL-level in the combustion chamber does not exceed 25 %). In any case the safety time of main burner shall not exceed 5 s and the safety time of pilot burners shall not exceed 10 s.

*Additional to [Table 3](#)*

All direct-ignition type burners shall be ignited at 350 kW or less.

**G.4.2.7.8 Flame failure during operation**

*Replaces the first paragraph of [4.2.7.8](#)*

In any event of flame failure during operation shall go to lock-out.

**G.4.3.1.1 Pipework, General**

*Additional to [4.3.1.1](#)*

Materials for oil pipes shall be as specified in JIS G 3454; JIS G 3455; JIS G 3456; or JIS G 3459, as applicable. Materials for welded fittings shall be as specified in JIS B 2312, and materials for flanged fittings shall be as specified in JIS B 2220.

**G.4.3.7.1 Pre-purging of the combustion chamber**

*Replaces paragraphs 4, 9 and 10 of [4.3.7.1](#)*

The case the pre-purge may be omitted is limited to the following cases:

- a) when the combustion chamber is proved to be at a temperature above 750 °C (as defined for high temperature equipment);
- b) in a multiple-burner system, one or more burners are burning in the common combustion chamber or the combustion zone;
- c) when starting burner after shutdown for control reason and;
  - 1) a pilot burner equipped with a dedicated flame safeguard is burning continuously or
  - 2) in a pulse combustion system with a specifically equipped ignition source, a flame supervisor dedicated to the main burner is equipped or
  - 3) the furnace atmosphere is proven to be less than 25 % of the lower explosion limit or
  - 4) the radiant tube is metallic, resistant to explosion, and is equipped with a specifically equipped ignition source.

**G.4.3.7.5 Maximum safety times**

*Additional to [Table 4](#) in [4.3.7.5](#)*

All direct-ignition type burners shall be ignited at 350 kW or less.

**G.4.3.7.7 Flame failure during operation**

*Replaces the first paragraph of [4.3.7.7](#)*

In any event of flame failure during operation shall go to lock-out.

**G.4.5.5 Oxygen or oxygen-enriched air (OOECA)**

*Additional to [4.5.5](#)*

Piping for oxygen or oxygen-enriched air shall be as specified in JIS G 3452, JIS G 3454, JIS G 3459 and JIS H 3300.

## Annex H (normative)

### Requirements specific to the USA

#### H.1 General

Only those provisions of this part of ISO 13577 that are affected by requirements specific to the USA have been identified in this annex, numbered correspondingly to the respective subclauses in the main body of the standard.

The requirements of this annex shall ensure a level of safety at least equivalent to that provided by the requirements in the main body of this part of ISO 13577.

#### H.2 Background

For equipment intended to be used in the USA, the “Authority Having Jurisdiction” (AHJ) has the ultimate authority to approve the overall system installation of the equipment. The AHJ may be a State Government, local Fire Marshall, local building inspector, local board or commission, the user’s insurance underwriter, an engineer or the end user. The US Federal and State Governments have occupational safety and health requirements for a given installation via the Occupation Safety and Health Administration (OSHA), but OSHA does not typically act as the AHJ during the initial installation and commissioning of the equipment.

The OSHA requirements for the USA (29 CFR Part 1910 General Industry Standards) can be downloaded at <http://www.osha.gov/>. Some common hazards are covered in ISO 13577-1:2012, Clause 4 in the “List of hazards”. However, complying with these may not be enough to satisfy the OSHA requirements in the USA for a given installation. Should OSHA determine that an American National Standard would provide a higher level of safety than the International Standard, OSHA could impose the requirements of other American National Standards in addition to the requirements of the International Standard for a given installation.

The end user is responsible for identifying and communicating with the AHJ for a given installation.

For applications covered under this part of ISO 13577, NFPA 86 is the recognized American National Standard in the USA. The scope of NFPA 86 is limited to hazards associated with fires and explosions. In addition to equipment requirements, it also includes requirements for the end user and the installation location, whereas this part of ISO 13577 only covers requirements for the thermal processing equipment (TPE). Thus, complying with this part of ISO 13577 does not mean that the installation will meet the requirements of NFPA 86 or the AHJ, who might have additional or different requirements than those in this part of ISO 13577. However, since all installations are subject to approval of the AHJ, it is possible for equipment complying with the requirements of this part of ISO 13577 to be accepted.

#### H.3 Normative references

ANSI/ASME B1.20.1, *Pipe Threads, General Purpose (inch)*

ANSI/ASME B31.1, *Power Piping*

ANSI/ASME B31.3, *Process Piping*

ANSI/ASME B16.20, *Metallic Flat Gaskets for Pipe Flanges*

ANSI/ASME B16.21, *Non Metallic Flat Gaskets for Pipe Flanges*

International Fuel Gas Code

NFPA 31, *Standard for the Installation of Oil-Burning Equipment*

NFPA 54, *National Fuel Gas Code*

NFPA 55, *Compressed Gases and Cryogenic Fluids Code*

NFPA 70, *National Electrical Code*

NFPA 79, *Electrical Standard for Industrial Machinery*

NFPA 86, *Standard for Ovens and Furnaces*

UL 353, *Limit Controls*

FM 3510, *Flow and Pressure Safety Switches*

UL 873, *Temperature-Indicating and -Regulating Equipment*

FM 3545, *Temperature Limit and Supervisory Switches*

CGA G-4.1, *Cleaning Equipment for Oxygen Service*

CGA G-4.4, *Oxygen Pipeline Systems*

## **H.4 Requirements**

### **H.4.1 General**

*Additional to [4.1](#)*

The electrical installation shall comply with the following:

- NFPA 70 National Electrical Code
- NFPA 79, Electrical Standard for Industrial Machinery

Where seal leakage or diaphragm failure in a device can result in flammable gas or flammable liquid flow through a conduit or cable to an electrical ignition source, a conduit seal or a cable type that is sealed shall be installed.

#### **H.4.2.1.1 Gas pipework – General**

*Additional to [4.2.1.1](#)*

The pipework materials shall comply with:

- NFPA 54, National Fuel Gas Code or International Fuel Gas Code.

#### **H.4.2.1.2 Connections**

*Additional to [4.2.1.2](#)*

The pipework connections including pressure limitations shall comply with the following, as applicable:

- ANSI/ASME B1.20.1, Pipe Threads, General Purpose (inch)
- ANSI/ASME B31.1, Power Piping
- ANSI/ASME B31.3, Process Piping
- ANSI/ASME B16.20, Metallic Flat Gaskets for Pipe Flanges

**ISO 13577-2:2014(E)**

- ANSI/ASME B16.21, Non Metallic Flat Gaskets for Pipe Flanges

**H.4.2.2.4 Low gas protection**

*Additional to [4.2.2.4](#)*

The devices shall comply with the following, as applicable:

- UL 353, Limit Controls
- FM 3510, Flow and Pressure Safety Switches

**H.4.2.2.5 High gas protection**

*Additional to [4.2.2.5](#)*

The devices shall comply with the following, as applicable:

- UL 353, Limit Controls
- FM 3510, Flow and Pressure Safety Switches

**H.4.2.2.6 Automatic shut-off valves**

*Additional to [4.2.2.6](#)*

Safety shutoff valves used in pulse firing, regenerative or other such high cycling applications shall be replaced before they exceed their maximum allowable number of lifetime open-closed cycles. The number of safety shutoff valve cycles shall be determined in one of the following ways:

- 1) By counting the number of actual safety shutoff valve open-closed cycles
- 2) By estimating the time to reach 90 percent of lifetime total cycles based on normal cycling rates

The instruction handbook shall contain details of the maintenance intervals and procedures for all safety in compliance with NFPA 86:2011, Standard for Ovens and Furnaces – Chapter 7 – Commissioning, Operations, Maintenance, Inspection and Testing.

**H.4.2.2.7 Valve proving**

*Additional to [4.2.2.7](#)*

Valve proving is required for all capacities above 117 kW (400,000 Btu/h), based on the higher calorific value, and for all operating conditions without regard to the number of start-ups anticipated per year.

**H.4.2.3.2 Air flow and pressure detectors**

*Additional to [4.2.3.2](#)*

The devices shall comply with the following, as applicable:

- UL 353, Limit Controls
- FM 3510, Flow and Pressure Safety Switches

**H.4.2.7.1 Pre-purging of the combustion chamber**

*Additional to [4.2.7.1](#) for pulse fired burners*

Re-starting without a re-purge is permitted only when it can be demonstrated that the combustible concentration in the heating chamber and all other passages that handle the recirculation and exhaust of products of combustion cannot exceed 25 percent of the Lower Flammable Limit.

*Additional to [4.2.7.1](#) for regenerative burners*

Re-starting without a re-purge is permitted only when it can be demonstrated that the combustible concentration in the heating chamber and all other passages that handle the recirculation and exhaust of products of combustion cannot exceed 25 percent of the Lower Flammable Limit.

#### **H.4.3.1.1 Liquid fuel pipework – general**

*Additional to [4.3.1.1](#)*

The pipework materials shall comply with:

- NFPA 31, Standard for the Installation of Oil-Burning Equipment

#### **H.4.3.1.2 Connections**

*Additional to [4.3.1.2](#)*

The pipework connections including pressure limitations shall comply with the following, as applicable:

- ANSI/ASME B1.20.1, Pipe Threads, General Purpose (inch).
- ANSI/ASME B31.1, Power Piping
- ANSI/ASME B31.3, Process Piping
- ANSI/ASME B16.20, Metallic Flat Gaskets for Pipe Flanges
- ANSI/ASME B16.21, Non Metallic Flat Gaskets for Pipe Flanges

#### **H.4.3.2.6 Liquid fuel pressure protection**

*Additional to [4.3.2.6](#)*

The devices shall comply with the following, as applicable:

- UL 353, Limit Controls
- FM 3510, Flow and Pressure Safety Switches

#### **H.4.3.2.7 Liquid fuel temperature protection**

*Additional to [4.3.2.7](#)*

The devices shall comply with the following, as applicable:

- UL 873, Temperature-Indicating and -Regulating Equipment
- FM 3545, Temperature Limit and Supervisory Switches

#### **H.4.3.2.8 Automatic shut-off valves**

*Additional to [4.3.2.8](#)*

**ISO 13577-2:2014(E)**

Safety shutoff valves used in pulse firing, regenerative or other such high cycling applications shall be replaced before they exceed their maximum allowable number of lifetime open-closed cycles. The number of safety shutoff valve cycles shall be determined in one of the following ways:

- a) By counting the number of actual safety shutoff valve open-closed cycles.
- b) By estimating the time to reach 90 % of lifetime total cycles based on normal cycling rates.

The instruction handbook shall contain details of the maintenance intervals and procedures for all safety in compliance with NFPA 86:2011, Standard for Ovens and Furnaces – Chapter 7 – Commissioning, Operations, Maintenance, Inspection and Testing.

**H.4.3.2.9 Automatic shut-off valves for multiple burners**

*Additional to [4.3.2.9](#)*

Safety shutoff valves used in pulse firing, regenerative or other such high cycling applications shall be replaced before they exceed their maximum allowable number of lifetime open-closed cycles. The number of safety shutoff valve cycles shall be determined in one of the following ways:

- a) By counting the number of actual safety shutoff valve open-closed cycles.
- b) By estimating the time to reach 90 % of lifetime total cycles based on normal cycling rates.

The instruction handbook shall contain details of the maintenance intervals and procedures for all safety in compliance with NFPA 86:2011, Standard for Ovens and Furnaces – Chapter 7 – Commissioning, Operations, Maintenance, Inspection and Testing.

**H.4.3.3.2 Air flow and pressure detectors**

*Additional to [4.3.3.2](#)*

The devices shall comply with the following, as applicable:

- UL 353, Limit Controls
- FM 3510, Flow and Pressure Safety Switches

**H.4.3.7.1 Pre-purging of the combustion chamber**

*Additional to [4.3.7.1](#) for pulse fired burners*

Re-starting without a re-purge is permitted only when it can be demonstrated that the combustible concentration in the heating chamber and all other passages that handle the recirculation and exhaust of products of combustion cannot exceed 25 % of the LFL.

*Additional to [4.3.7.1](#) for regenerative burners*

Re-starting without a re-purge is permitted only when it can be demonstrated that the combustible concentration in the heating chamber and all other passages that handle the recirculation and exhaust of products of combustion cannot exceed 25 % of the LFL.

**H.4.5.1 Oxygen or oxygen-enriched combustion air (OOECA) - General**

*Additional to [4.5.1](#)*

Equipment shall comply with the following, as applicable:

- NFPA 55, Compressed Gases and Cryogenic Fluids Code
- NFPA 86, Standard for Ovens and Furnaces, Oxygen-Enhanced Fuel-Fired Units

- NFPA 86, Standard for Ovens and Furnaces, Oxygen Safety Devices

#### **H.4.5.2 Suitability for oxygen service**

*Additional to [4.5.2](#)*

Equipment shall comply with the following, as applicable:

- CGA-4.1, Cleaning Equipment for Oxygen Service
- CGA-4.4, Oxygen Pipeline Systems

### **H.5 Bibliography**

United States Department of Labor – OSHA - 29 CFR Part. General Industry Standards, 1910

## Annex I (normative)

### Requirements for Europe and associated countries

#### I.1 General

Only those provisions of this part of ISO 13577 that are affected by requirements specific to Europe and associated countries have been identified in this annex, numbered correspondingly to the respective subclauses in the main body of the standard.

The requirements of this annex shall ensure a level of safety at least equivalent to that provided by the requirements in the main body of this part of ISO 13577.

#### I.2 Background

For TPE intended to be used in the European EEC member countries, in the European EFTA member countries accepting European (EEC) legislation, and in all other countries accepting European legislation, it shall be noted that this part of ISO 13577 specifies the specific essential health and safety requirements of annex 1 of the applicable Directive the standard is referring to or harmonized under, and only for the products in the scope of this part of ISO 13577.

This means that essential requirements of other European Directives could be applicable.

Examples of potential additional requirements are:

- equipment intended to be used in hazardous locations shall additionally comply with EEC-ATEX-requirements;
- equipment used under pressure (vessels, piping) exceeding 50 kPa may additionally need to comply with EEC-PED-requirements;
- equipment used with voltages between certain limits shall additionally comply with EEC-Low Voltage and EEC-EMC requirements.

It shall be verified in the scope of the European Directives themselves if the Directive is additionally applicable.

Other requirements are not in the clauses of this part of ISO 13577, but are specified in the EEC-Directives themselves. Certification requirements, declaration requirements, literature requirements, language requirements are specified in each Directive. It shall be verified, for each applicable Directive, which additional requirements are applicable, for the TPE before it is installed and commissioned in above specified countries.

#### I.3 Normatives references

EN 88-1:2011, *Pressure regulators and associated safety devices for gas appliances — Part 1: Pressure regulators for inlet pressures up to and including 50 kPa*

EN 88-2:2007, *Pressure regulators and associated safety devices for gas appliances — Part 2: Pressure regulators for inlet pressures above 500 mbar up to and including 5 bar*

EN 125:1991, *Flame supervision devices for gas burning appliances — Thermoelectric flame supervision devices*

**SANS 13577-2:2023**

- EN 125/A1:1996, *Flame supervision devices for gas burning appliance — Thermo-electric types, Amendment A1*
- EN 298:2003, *Automatic gas burner control systems for gas burners and gas burning appliances with or without fans*
- EN 331:1998, *Manually operated ball valves and closed bottom taper plug valves for gas installations for buildings*
- EN 334: 2005, *Gas pressure regulators for inlet pressures up to 100 bar*
- EN 730-1:2002, *Gas welding equipment — Safety devices — Part 1: Incorporating a flame (Flashback) arrestor*
- EN 730-2:2002, *Gas welding equipment — Safety devices — Part 2: Not Incorporating a flame (Flashback) arrestor*
- EN 751-1:1996, *Sealing materials for metallic threaded joints in contact with 1st, 2nd and 3rd family gases and hot water — Part 1: Anaerobic jointing compounds*
- EN 751-2:1996, *Sealing materials for metallic threaded joints in contact with 1st, 2nd and 3rd family gases and hot water — Part 2: Non-hardening jointing compounds*
- EN 1057:2006, *Copper and copper alloys - Seamless, round copper tubes for water and gas in sanitary and heating applications*
- EN 1643:2000, *Valve proving systems for automatic shut-off valves for gas burners and gas appliances*
- EN 1797:2001-7, *Cryogenic vessels — Gas/material compatibility*
- EN 1854:2006, *Pressure sensing devices for gas burners and gas burning applications*
- EN 10208-1:1997, *Steel pipes for pipe lines for combustible fluids — Technical delivery conditions — Part 1: Pipes of requirement class A*
- EN 10208-2:2009, *Steel pipes for pipelines for combustible fluids — Technical delivery conditions — Part 2: Pipes of requirement class B*
- EN 10241:2001, *Steel threaded pipe*
- EN 10242:1995, *Threaded pipe fittings in malleable cast iron*
- EN 10242/A1:1999, *Threaded pipe fittings in malleable cast iron*
- EN 10242/A2:2003, *Threaded pipe fittings in malleable cast iron*
- EN 10255:2004, *Non-Alloy steel tubes suitable for welding and threading — Technical delivery conditions*
- EN 10255/A1:2007, *Non-Alloy steel tubes suitable for welding and threading — Technical delivery conditions*
- EN 12067-2:2004, *Gas/air ratio controls for gas burners and gas burning appliances — Part 2: Electronic types*
- EN 13480-2:2002, *Metallic industrial piping — Part 2: Materials*
- EN 14382:2005, *Safety devices for gas pressure regulating stations and installations — Gas safety shut-off devices for inlet pressures up to 100 bar*

## ISO 13577-2:2014(E)

### I.4 Requirements

#### I.4.2.1.1 Gas pipework – General

*Additional to [4.2.1.1](#)*

For steel pipes, compliance with EN 10208-1 and EN 10208-2, EN 13480-2 (Table A.3), or EN 10255 is considered appropriate. For copper pipes compliance with EN 1057 is considered appropriate. Copper Soldering connections shall not be used for gas carrying parts where the temperature could exceed 100°C.

Threaded pipe fittings shall comply with EN 10241 or EN 10242.

#### I.4.2.1.2 Connections

*Additional to [4.2.1.2](#)*

Sealants for threads according to ISO 7-1 shall comply with EN 751-1 or EN 751-2 as appropriate.

For diameters DN 50 to DN 80, threaded connections shall only be used for pressure up to 10 kPa.

#### I.4.2.2.1 Manual isolating valve

*Additional to [4.2.2.1](#)*

If technically applicable, only manual isolating valves complying with EN 331 shall be fitted. For valves outside the scope of EN 331, the safety requirements detailed in EN 331 shall be met at an equivalent level.

#### I.4.2.2.3 Gas pressure regulator

*Additional to [4.2.2.3](#)*

Gas pressure regulators shall be in accordance with EN 88-1, EN 88-2 or EN 334 as applicable.

A mechanical over pressure cut-off device shall be in accordance with EN 14382.

#### I.4.2.2.4 Low gas protection

*Additional to [4.2.2.4](#)*

Gas pressure detectors shall be in accordance with EN 1854.

#### I.4.2.2.5 High gas protection

*Additional to [4.2.2.5](#)*

Gas pressure detectors shall be in accordance with EN 1854.

#### I.4.2.2.6 Automatic shut-off valves

*Additional to [4.2.2.6](#)*

Automatic shut-off valve shall be in accordance with EN 161:2007.

A thermo-electric flame supervision device complying with EN 125 is acceptable for natural draught burners operating in open air with controlled capacities below 70 kW and for natural draft burners operating in combustion chamber with controlled capacities below 2,5 kW.

**I.4.2.2.7 Valve proving**

*Additional to [4.2.2.7](#)*

Automatic valve proving shall comply with EN 1643 or give an equivalent level of safety.

**I.4.2.2.8 Individual manual shut-off valves for burners**

*Additional to [4.2.2.8](#)*

The manual shut-off-valve shall comply with EN 331. For valves outside the scope of EN 331, the safety requirements detailed in EN 331 shall be met at an equivalent level.

**I.4.2.3.2 Air flow and pressure detectors**

*Additional to [4.2.3.2](#)*

Air pressure detectors shall be in accordance with EN 1854.

**I.4.2.3.3 Air/fuel ratio**

*Additional to [4.2.3.3](#)*

A Pneumatic gas/air ratio controls shall be in accordance with EN 88-1.

Electronic gas/air ratio controls shall be in accordance with EN 12067-2.

**I.4.2.6.1 Automatic burner control systems General**

*Additional to [4.2.6.1](#)*

Automatic burner control systems shall comply with EN 298 or EN 125, if technically applicable. If necessary for process reasons, the characteristics of the system shall differ from the requirements specified in EN 298 or EN 125 providing the levels of safety and reliability are not reduced.

**I.4.2.6.4 Automatic burner control systems for burners operating in the open air**

*Additional to [4.2.6.4](#)*

Each burner firing in the open air with a rated heat input greater than 70 kW shall be fitted with an automatic burner control system complying, if technically applicable, with EN 298 or EN 125.

If the flame cannot be observed continuously from the workplace, an automatic burner control system complying, if technically applicable, with EN 298 or EN 125 shall be provided.

**I.4.3.1.1 Liquid fuel pipework – General**

*Additional to [4.3.1.1](#)*

For steel pipes, compliance with EN 10208-1 and EN 10208-2, EN 13480-2 (Table A.3), or EN 10255 is considered appropriate. For copper pipes compliance with EN 1057 is considered appropriate.

**I.4.3.2.8 Automatic shut-off valves**

*Additional to [4.3.2.8](#)*

Automatic shut-off valve shall be in accordance with EN 264 if applicable.

**ISO 13577-2:2014(E)****I.4.5.8 Flexible tubing and couplings**

*Additional to [4.5.8](#)*

Manual torches shall be equipped with a flash back arrestor (EN 730-1 or equivalent) and a lockable manual shut-off valve upstream of the hose.

**I.4.5.9 Safety devices against gas backflow**

*Additional to [4.5.9](#)*

Oxygen pipework shall be equipped with a non return valve (EN 730-2 or equivalent) suitable for the operating pressure.

**I.4.5.11 Material requirements**

*Additional to [4.5.11](#)*

NOTE Regarding the selection and compatibility of materials and gases (including oxygen) see also EN 1797.

## Bibliography

- [1] ISO 6976, *Natural gas — Calculation of calorific values, density, relative density and Wobbe index from composition*
- [2] ISO 13849 (all parts), *Safety of machinery — Safety-related parts of control systems*
- [3] ISO 14118:2000, *Safety of machinery — Prevention of unexpected start-up*
- [4] ISO 23550:2011, *Safety and control devices for gas burners and gas-burning appliances — General requirement*
- [5] ISO 23551-4, *Safety and control devices for gas burners and gas-burning appliances — Particular requirements — Part 4: Valve-proving systems for automatic shut-off valves*
- [6] ISO 22967:2010, *Forced draught gas burners*
- [7] ISO 22968:2010, *Forced draught oil burners*
- [8] IEC 61508 (all parts), *Functional safety of electrical/electronic/programmable electronic safety-related systems*
- [9] IEC 61511 (all parts), *Functional safety — Safety instrumented systems for the process industry sector*
- [10] IEC 62061, *Safety of machinery — Functional safety of safety-related electrical, electronic and programmable electronic control systems*
- [11] EN 525:1997, *Non-domestic direct gas-fired forced convection air heaters for space heating not exceeding a net heat input of 300 kW*
- [12] EN 1539:2000, *Dryers and ovens, in which flammable substances are released — Safety requirements*
- [13] EN 1547:2001 + A1:2009, *Industrial thermoprocessing equipment — Noise test code for industrial thermoprocessing equipment including its ancillary handling equipment*
- [14] EN 10217-1:2005, *Welded steel tubes for pressure purposes — Technical delivery conditions — Part 1: Non- alloy steel tubes with specified room temperature properties*
- [15] EN 10220:2002, *Seamless and welded steel tubes — General tables of dimensions and masses per unit length*
- [16] EN 12300:1998, *Cryogenic vessels — Cleanliness for cryogenic service*
- [17] EN 13611:2007+A2:2011, *Safety devices for gas burners and gas burning appliances — General requirements*
- [18] EN 14597:2012, *Temperature control devices and temperature limiters for heat generating systems*
- [19] EIGA IGC Doc 13/12/E *Oxygen pipeline and piping systems*; available at [https://www.eiga.eu/fileadmin/docs\\_pubs/Doc\\_13\\_12\\_Oxygen\\_Pipeline\\_and\\_Piping\\_Systems.pdf](https://www.eiga.eu/fileadmin/docs_pubs/Doc_13_12_Oxygen_Pipeline_and_Piping_Systems.pdf)

**Annex AA**

(normative)

**National modifications to ISO 13577-2****Introduction**

*Add the following:*

This applies to all combustion and fuel-handling equipment used in industrial thermoprocessing equipment and systems that operate above 0,5 GJ/h. It also applies to the fuel pipework immediately adjacent to the equipment downstream of the manual isolating valve.

Where natural gas or LPG are supplied to the thermoprocessing equipment directly from a bulk storage facility or external supply line, the piping from the main plant fuel shut off valve to the manual isolation valve of the thermoprocessing equipment is included in the scope of this part of ISO 13577-2.

Only those provisions of this part of ISO 13577 that are affected by requirements specific to South Africa have been identified in this annex, numbered correspondingly to the respective subclauses in the main body of the standard.

The requirements of this annex should ensure a level of safety at least equivalent to that provided by the requirements in the main body of this part of ISO 13577.

For TPE intended to be used in the South Africa, it shall be noted that this part of ISO 13577 specifies the specific essential health and safety requirements of the Pressure Equipment Regulations (see foreword), and only for the products in the scope of this part of ISO 13577. This means that essential requirements of other European Directives could be applicable.

Examples of potential additional requirements are:

- a) equipment intended to be used in hazardous locations should comply with the relevant national legislation (see foreword), SANS 10142-1, and SANS 10142-2 as applicable;
- b) Equipment under pressure with a design pressure exceeding 50 kPa should additionally comply with the requirements of SANS 347 and the relevant national legislation (see foreword);
- c) equipment used with voltages within certain limits should comply with the Electrical Machinery Regulations (see foreword), SANS 10142-1 and SANS 10142-2 as applicable; and
- d) buildings used to house or used in connection with TPE should comply with the relevant national legislation (see foreword), SANS 10400 (all parts).

It should be verified in the scope of the relevant national legislation (see foreword) if the legislation is additionally applicable.

Declaration requirements, literature requirements, language requirements are specified for each applicable in the relevant national legislation (see foreword).

It should be verified, for each applicable Regulations of the relevant national legislation (see foreword) which additional requirements are applicable, for the TPE before it is installed and commissioned.

**Clause 2**

*Add the following:*

API Spec 5L, *Specification for line pipe.*

ANSI/ASME B1.20.1, *Pipe threads, general purpose (inch).*

ANSI/ASME B31.1, *Power piping.*

ANSI/ASME B31.3, *Process piping.*

ANSI/ASME B16.20, *Metallic flat gaskets for pipe flanges.*

ANSI/ASME B16.21, *Non metallic flat gaskets for pipe flanges.*

ASME B16.5, *Pipe flanges and flange fittings.*

ASME B16.34, *Valves flanged threaded and welded end.*

ASTM A106, *Standard specification for seamless carbon steel pipe for high-temperature service.*

ASTM B280, *Standard specification for seamless copper tube for air conditioning and refrigeration field service.*

ASTM G63, *Standard guide for evaluating non-metallic materials for oxygen service.*

ASTM G93, *Standard practice for cleaning methods and cleanliness levels for material and equipment used in oxygen-enriched environments.*

ASTM G127, *Standard guide for the selection of cleaning agents for oxygen systems.*

IGC 13/12/E, *Oxygen pipelines and piping systems.*

EN 88-2, *Pressure regulators and associated safety devices for gas appliances – Part 2: Pressure regulators for inlet pressures above 500 mbar up to and including 5 bar.*

EN 126, *Multifunctional controls for burners.*

EN 161, *Automatic shut-off valves for gas burners and gas appliances.*

EN 298, *Automatic burner control systems for burners and appliances burning gaseous or liquid fuels.*

EN 751-1, *Sealing materials for metallic threaded joints in contact with 1st, 2nd and 3rd family gases and hot water – Part 1: Anaerobic jointing compounds.*

EN 751-2, *Sealing materials for metallic threaded joints in contact with 1st, 2nd and 3rd family gases and hot water – Part 2: Non-hardening jointing compounds.*

EN 1643, *Valve proving systems for automatic shut-off valves for gas burners and gas appliances.*

EN 12067-2, *Gas/air ratio controls for gas burners and gas burning appliances – Part 2: Electronic types.*

EN 13480-2, *Metallic industrial piping – Part 2: Materials.*

EN 13480-3, *Metallic industrial piping – Part 3: Design and calculation.*

EN 13611, *Safety devices for gas burners and gas burning appliances – General requirements.*

EN 16129, *Pressure regulators, automatic change-over devices, having a maximum regulated pressure of 4 bar, with a maximum capacity of 150 kg/h, associated safety devices and adaptors for butane, propane, and their mixtures.*

IEC 60730-2-6, *Automatic electrical controls – Part 2-6: Particular requirements for automatic electrical pressure sensing controls including mechanical requirements.*

ISO 3183, *Petroleum and natural gas industries – Steel pipe for pipeline transportation systems.*

ISO 7005-3, *Metallic flanges – Part 3: Copper alloy and composite flanges.*

ISO 14313, *Petroleum and natural gas industries – Pipeline transportation systems – Pipeline valves.*

ISO 17292, *Metal ball valves for petroleum, petrochemical and allied industries.*

ISO 22967, *Forced draught gas burners.*

ISO 23550, *Safety and control devices for gas burners and gas-burning appliances – General requirements.*

ISO 23551-4, *Safety and control devices for gas burners and gas-burning appliances – Particular requirements – Part 4: Valve-proving systems for automatic shut-off valves.*

ISO 23553-1, *Safety and control devices for oil burners and oil-burning appliances – Particular requirements – Part 1: Automatic and semi-automatic valves*

SANS 62-1, *Steel pipes – Part 1: Pipes suitable for threading and of nominal size not exceeding 150 mm.*

SANS 62-2, *Steel pipes – Part 2: Screwed pieces and pipe fittings of nominal size not exceeding 150 mm.*

SANS 347, *Categorization and conformity assessment criteria for all pressure equipment.*

SANS 460, *Plain-ended solid drawn copper tubes for potable water.*

SANS 1109-1/ISO 7-1, *Pipe threads where pressure-tight joints are made on the threads – Part 1: Dimensions, tolerances and designation.*

SANS 1306-1/ISO 228-1, *Pipe threads where pressure-tight joints are not made on the threads – Part 1: Dimensions, tolerances and designation.*

SANS 4437-1/ISO 4437-1, *Plastics piping systems for the supply of gaseous fuels – Polyethylene (PE) Part 1: General*

SANS 4437-2/ISO 4437-2, *Plastics piping systems for the supply of gaseous fuels – Polyethylene (PE) Part 2: Pipes.*

SANS 4437-3/ISO 4437-3, *Plastics piping systems for the supply of gaseous fuels – Polyethylene (PE) – Part 3: Fittings.*

SANS 4437-5/ISO 4437-4, *Plastics piping systems for the supply of gaseous fuels – Polyethylene (PE) – Part 5: Fitness for purpose of the system.*

SANS 5817, *Timber based board products – Squareness.*

SANS 7005-1/ISO 7500-1, *Metallic flanges – Part 1: Steel flanges.*

SANS 7005-2/ISO 7500-2, *Metallic flanges – Part 2: Cast iron flanges.*

SANS 10140-3, *Identification colour markings – Part 3: Contents of pipelines.*

SANS 10142-1, *The wiring of premises – Part 1: Low-voltage installations.*

SANS 10142-2, *The wiring of premises – Part 2: Medium-voltage installations above 1 kV a.c. not exceeding 22 kV a.c. and up to and including 3 000 MVA installed capacity.*

SANS 10260-1, *Industrial gas pipelines – Part 1: Design, construction, installation, operation, examination and maintenance (excluding acetylene).*

SANS 10400 (all parts), *The application of the National Building Regulations.*

SANS 13774/EN 13774, *Valves for gas distribution systems with maximum operating pressure less than or equal to 16 bar – Performance requirements.*

SANS 50088-1/EN 88-1, *Pressure regulators and associated safety devices for gas appliance – Part 1: Pressure regulators for inlet pressures up to and including 500 kPa.*

SANS 50125/EN 125, *Flame supervision devices for gas burning appliances – Thermoelectric flame supervision devices.*

SANS 50331/EN 331, *Manually operated ball valves and closed bottom taper plug valves for gas installations for buildings.*

SANS 50334/EN 334, *Gas pressure regulators for inlet pressures up to 100 bar.*

SANS 50676/EN 676, *Automatic forced draught burners for gaseous fuels.*

SANS 51854/EN 1854, *Pressure sensing devices for gas burners and gas burning appliances.*

SANS 54382/EN 14382, *Gas safety shut-off devices for inlet pressure up to 10 MPa (bar).*

#### **Subclause 4.2.1.1**

*Add the following:*

Steel pipe for pressure equipment shall comply with the requirements of the relevant national legislation (see foreword) PER, and EN 13480-2, or listed materials within the ASME B31 code (ASTM A or B). The following material grades can also be used:

- a) SANS 62-1 (for medium duty); or
- b) API Spec 5L for schedule 40 piping; or
- c) ASTM A106 grade B for schedule 40 piping.

Copper tube shall comply with the requirements of SANS 460 and be of at least a class 2, ASTM B280. Copper tube shall not be used in applications where the temperature is likely to exceed 100 °C with a maximum diameter of 10 mm. In a case of high density polyethylene (HDPE), SANS 4437 shall be used. HDPE pipe shall only be used underground.

**Subclause 4.2.1.2**

*Add the following:*

Hemp shall not be used under any circumstances. Sealants for threads according to ISO 7-1 shall comply with EN 751-1 or EN 751-2 as appropriate. The pipework connections including pressure limitations done according to ASME shall comply with ANSI/ASME B1.20.1, ANSI/ASME B31.1, ANSI/ASME B31.3, ANSI/ASME B16.20, ANSI/ASME B16.21, and ASME B16.5 as applicable. The pipework connections including pressure limitations done according to EN shall comply with EN 13480-3, as applicable.

**Subclause 4.2.1.6**

*Add the following:*

Where colour coding is used, it shall comply with SANS 10140-3.

**Subclause 4.2.1.7**

*Add the following:*

Pressure testing and frequency of testing shall be done in accordance with the requirements of the relevant national legislation (see foreword) Pressure Equipment Regulations and SANS 347.

**Subclause 4.2.1.9**

*Add the following:*

Purge points shall be installed at the furthestmost appropriate point(s) of the installation and be purged into a safe discharge area to the outside atmosphere.

NOTE LPG is heavier than air, therefore it should be purged into an area where no drains or depressions are found.

**Subclause 4.2.1.15**

*Add the following:*

If closing of a process isolation valve is required to enable online maintenance, it will only be permitted under strict permit conditions and by following appropriate procedures ensuring that no unsafe conditions are created.

**Subclause 4.2.2.1**

*Add the following:*

Manually operated threaded isolation valves shall comply with the requirements of SANS 50331 and flanged isolation valves shall comply with EN 13774. All other valves shall conform to ISO 14313 or ISO 17292 or ASME B 16.34, as applicable.

**Subclause 4.2.2.3**

*Add the following:*

Alternatively, gas pressure regulators shall be in accordance with EN 88-1, EN 88-2, SANS 50334, EN 16129 or ISO 23550 as applicable. Alternatively, a mechanical over pressure cut-off device shall be in accordance with EN 14382 or ISO 23550. Alternatively, the over pressure cut-off device can also be designed using an over pressure switch in accordance with SANS 51854 combined with a safety shut-off valve that complies with EN 161.

**Subclause 4.2.2.4**

*Add the following:*

Alternatively, gas pressure detectors shall be in accordance with SANS 51854.

**Subclause 4.2.2.5**

*Add the following:*

Alternatively, gas pressure detectors shall be in accordance with SANS 51854.

**Subclause 4.2.2.6**

*Add the following:*

Automatic shut-off valve shall be in accordance with EN 161. A thermo-electric flame supervision device complying with SANS 50125 is acceptable for natural draught burners operating in open air with controlled capacities below 70 kW and for natural draft burners operating in combustion chamber with controlled capacities below 2,5 kW.

**Subclause 4.2.2.7**

*Add the following:*

Automatic valve proving shall comply with EN 1643, ISO 23551-4 or ISO 23550.

**Subclause 4.2.3.2**

*Add the following:*

Alternatively, air pressure detectors shall be in accordance with SANS 51854.

**Subclause 4.2.3.3**

*Add the following:*

Alternatively, a pneumatic gas or air ratio controls shall be in accordance with EN 88-1 or ISO 23550. Alternatively, electronic gas or air ratio controls shall be in accordance with EN 12067-2 or ISO 23550.

**Subclause 4.2.5**

*Add the following:*

Package burners shall be in accordance with SANS 50676 or ISO 22967.

**Subclause 4.2.5.5**

*Add the following:*

The correct air quality for the operator shall be in accordance with the relevant national legislation (see foreword).

**Subclause 4.2.6.1**

*Add the following:*

Automatic burner control systems shall comply with EN 298 or SANS 50125, if technically applicable. If necessary, for process reasons, the characteristics of the system shall differ from the requirements specified in EN 298 or EN 13611 or SANS 50125 provided the levels of safety and reliability are not reduced. Where manual checking of the automatic burner control system is carried out, the instruction handbook shall specify the procedures to be followed in the event of a malfunction.

All multifunctional control devices having two or more functions, one of which is shut-off function, integrated within one housing and whereby the functional parts cannot operate if separated. This applies to multifunctional controls of nominal connection size up to and including DN 150 with declared maximum working pressure up and including 50 kPa for use on burners or in appliances for use with one or more fuel gases of the 1<sup>st</sup>, 2<sup>nd</sup> or 3<sup>rd</sup> families in accordance with EN 126.

**Subclause 4.2.7.5**

*Amend table 2 as follows:*

Replace 2,5 kW with 25 kW.

**Subclause 4.2.7.7**

*Add the following:*

For pulse firing burners, flame failure of a single burner may cause safety shutdown instead of lockout. Three consecutive flame failures shall cause lockout. The total number of burners subject to this provision shall be limited. The number of burners shall be specified in the instruction handbook.

**Subclause 4.2.7.8**

*Add the following:*

In any combustion system, the turndown ratio shall be such that the burner(s) is fully stable at all firing conditions. Permanent pilot burners used in the case of main burners supplied with gas or combustible vapours with uncertain combustion characteristics (for example, varying calorific values), shall be independently supplied with a clean fuel gas of constant quality and be fitted with automatic burner control systems.

**Subclause 4.3.1.1**

*Add the following:*

Steel piping shall be as follows:

- a) where screwed joints are used, these shall be limited to pipes of nominal bore not exceeding 40 mm. Such pipes shall comply with the requirements of SANS 62-1, or API Spec 5L (or equivalent); pipe fittings shall be of wrought steel and of a grade at least equal to that of the mating pipes;
- b) pipes of nominal bore larger than 40 mm shall have welded or flanged joints and shall comply with the requirements of SANS 62-1, SANS 62-2 or API Spec 5L (or equivalent) or ISO 3183; and
- c) the use of steel pipes in critical areas shall be in accordance with the following:
  - 1) Pipes shall not pass through the cavity of cavity walls or through lift shafts, flues, ceiling(s) or ceiling or floor voids and air ducts unless they are sleeved or welded as applicable.

- 2) Where pipes pass through walls that might or might not be regarded as cavity walls, such pipes shall be sleeved.
- 3) Pipe routes shall not be placed inside the void of a cavity wall.
- 4) For pipework falling under category I of SANS 347, the requirements of SANS 347 can be used as an alternative to the requirements of 4.3.1.1. In cases where the pipework is within the boundaries of category II or III of SANS 347, then the additional requirements of SANS 347 shall apply.

For steel pipes, compliance with ISO 3183, EN 13480-2, or EN 10255 is also considered appropriate. For copper pipes compliance with EN 1057 is also considered appropriate.

**Subclause 4.3.1.2**

*Add the following:*

Where the equipment has a threaded connection, this thread shall comply with SANS 1306-1 or SANS 1109-1, as appropriate. In the case of parallel threads, care shall be taken to ensure an acceptable seal. Other threaded connections may be used providing they ensure tight connections and are identified.

Flanges shall comply with SANS 7005-1, SANS 7005-2 and ISO 7005-3 or equivalent, as appropriate. The sealants used shall comply with EN 751-1 or EN 751-2, as appropriate. Arc welding shall comply with SANS 5817, quality level C.

**Subclause 4.3.2.8**

*Add the following:*

Automatic shut-off valve shall be in accordance with ISO 23553-1, if applicable.

**Subclause 4.3.2.9**

*Add the following:*

Where two automatic shut-off valves are required (see 4.3.2.8), an individual burner may be shut down by a single automatic shut-off valve in the event of flame failure or for other process reasons (for example, thermal input), providing that the following conditions are satisfied:

- a) no other failure occurs (for example, pressure or temperature fluctuations);
- b) a proof of closure device is fitted;
- c) a specific risk analysis is documented in the technical file to prove that the levels of safety have not been compromised;
- d) the results of this risk analysis (including any specific process, operational or maintenance requirements and the number of burners permitted to operate under these conditions before two safety shut-off valves in series shall be closed to shut down the associated group of burners) will be specified in the instructions for use; and
- e) the protective system shall check for the absence of a flame after the shut-off valve has been closed. If a flame is detected, a flame failure alarm will occur.

The capacity control functions (valves and circuitry) shall not override the automatic shut-off functions. The automatic shut-off valves can also be used for capacity control. However, independent sensing devices shall be used for capacity control and automatic shut off.

**Subclause 4.3.2.10**

*Add the following:*

Manually operated threaded isolation valves shall comply with the requirements of SANS 50331 and flanged isolation valves shall comply with EN 13774. All other valves shall conform to ISO 14313 or ISO 17292 or ASME B 16.34, as applicable. However, if the installation of such a manual valve affects the mixing characteristics of mixing devices (for example, venturi mixers), then the shut-off valve shall be installed upstream of any such device.

**Subclause 4.3.3.3**

*Add the following:*

Depending on the chosen technology, additional protective measures may be required (for example, frequency control of the combustion air blower, variable combustion chamber pressure, and preheated combustion air). The failure tolerance time for CO emission shall not exceed 30 min.

**Subclause 4.5.1**

*Add the following:*

Oxygen installations shall comply with SANS 10260-1 or IGC 13/12/E.

**Subclause 4.5.2**

*Add the following:*

Equipment shall comply with ASTM G63, ASTM G93, ASTM G127, as applicable.

**Subclause 6.3.1**

*Add the following:*

Copies of the safe gas equipment permits issued in terms of the relevant national legislation (see foreword).

**Annex E**

*Change annex E to be informative and add the following:*

Annex E is for information purposes.