

SOUTH AFRICAN NATIONAL STANDARD

Gas cylinder test stations — General requirements for periodic inspection and testing of transportable refillable gas pressure receptacles

WARNING

This document references other documents normatively.



This page has been left blank intentionally



COPYRIGHT PROTECTED DOCUMENT

© SABS

In terms of the Standards Act 8 of 2008, the copyright in all South African National Standards or any other publications published by the SABS Standards Division, vests in the SABS. Any use of South African National Standards is limited to use specifically prescribed by the SABS. In the case of a South African National Standard based on an international standard, ownership of the copyright vests in the organization from which the SABS adopted the standard, whether it be under licence or membership agreement. The SABS is obliged to protect such copyright and is authorized to make the relevant international organization aware of any misuse thereof. Unless exemption has been granted, no extract or full text of any South African National Standard may be copied, reproduced, stored in a retrieval system or transmitted in any form or by any means without prior written permission from the SABS Standards Division. This does not preclude the free use, in the course of implementing the standard, of necessary details such as symbols, and size, type or grade designations. If these details are to be used for any purpose other than implementation, prior written permission must be obtained.

Details, advice and limitations of use can be obtained from the Manager: Standards Sales and Information Services. Tel: +27 (0) 12 428 6883 email: sales@sabs.co.za

SABS – Standards Division

The objective of the SABS Standards Division is to develop, promote and maintain South African National Standards. This objective is incorporated in the Standards Act, 2008 (Act No. 8 of 2008).

The SABS continuously strives to improve the quality of its products and services and would therefore be grateful if anyone finding an inaccuracy or ambiguity while using this standard would inform the secretary of the technical committee responsible, the identity of which can be found in the foreword.

Buying Standards

Contact the Sales Office for South African and international standards, which are available in both electronic and hard copy format. Tel: +27 (0) 12 428 6883 email: sales@sabs.co.za

South African National Standards are also available online from the SABS Webstore www.store.sabs.co.za

Information on Standards

SABS Customer Services provide comprehensive standards-related information on national, regional and international standards. Tel: +27 (0) 12 428 7911 / 0861 27 7227 email: info@sabs.co.za

SANS 1825:2021
Edition 4.2

Table of changes

Change No.	Date	Scope
Amdt 1	2020	Amended to update the scope, and referenced standards, to move references to the relevant national departments, relevant national legislation, and the accreditation authority to the foreword, to update the clause on requirements, the table on qualification requirements for test station personnel, the table on basic equipment for test stations, the subclause on resale of and scrapping/rejection criteria for pressure receptacles, the annex on withdrawn cylinder specifications, the annex on LPG cylinder inspection and test procedures, and the annex on test pressure requirements for DOT pressure receptacles, and to add a bibliography.
Amdt 2	2021	Amended to update the table on intervals for periodic inspection and testing of pressure receptacles, the requirements for identification of cylinder and preparation for inspections and tests, and the requirements for cylinder records and inspection report/certificates, to add foot notes in the table for basic equipment for test stations, to update the requirements for resale of and scrapping/rejection criteria for pressure receptacles, and to update the annexes on withdrawn cylinder specifications, on LPG cylinder inspection and test procedures, and on test pressure requirements for DOT pressure receptacles, and referenced standards.

Foreword

This South African standard was prepared by National Committee SABS/TC 058, *Vessels and systems under pressure*, in accordance with procedures of the South African Bureau of Standards, in compliance with annex 3 of the WTO/TBT agreement.

This document was approved for publication in November 2021.

This document supersedes SANS 1825:2020 (edition 4.1).

A vertical line in the margin shows where the text has been technically modified by amendment No. 2.

Compliance with this document cannot confer immunity from legal obligations.

Reference is made in 3.1, 5.1.1, 5.1.2(a), (b) and (c), 5.3, and 5.4 to the "relevant government-endorsed national accreditation body". In South Africa this means the South African National Accreditation System (SANAS). **Amdt 1**

Reference is made in the introduction, 4.3, 5.1.2, 5.1.2(b) and (c) and 5.3 to the "relevant national department". In South Africa this means the Department of Employment and Labour. **Amdt 1**

Reference is made in note 2 to 3.6 and in table 2 to the "relevant national legislation". In South Africa this means Pressure Equipment Regulations of the Occupational Health and Safety Act, 1993 (Act No. 85 of 1993). **Amdt 1**

Foreword (concluded)

Reference is made in 3.7(a) to the "relevant national legislation". In South Africa this means the Occupational Health and Safety Act, 1993 (Act No. 85 of 1993). **Amdt 1**

Reference is made in 5.1.2(c) to the relevant national legislation". In South Africa this means the Pressure Equipment Regulations of the Occupational Health and Safety Act, 1993 (Act No. 85 of 1993). **Amdt 1**

Reference is made in table 2 to the "requirements of the government–endorsed national accreditation body". In South Africa this means the requirements SANAS R03. **Amdt 1**

Reference is made in table 2 to "an applicable training authority". In South Africa this means the Sector of Education and Training (SETA). **Amdt 1**

Reference is made in footnote (c) to table 3 to the "relevant national legislation". In South Africa this means the General Machinery Regulations of the Occupational Health and Safety Act, 1993 (Act No. 85 of 1993). **Amdt 1**

Reference is made in D.1.6 to the "relevant association". In South Africa this means the Liquefied Petroleum Gas Safety Association of South Africa (LPGSASA). **Amdt 1**

Annexes A, B, D, F and G form an integral part of this document. Annex C and E are for information only.

Introduction

The original periodic inspection and testing procedures for transportable refillable welded steel liquefied petroleum gas (LPG) cylinders were based on those for gas cylinders or other pressure vessels, including those used for high-pressure industrial gases. These early methods relied on a periodic hydraulic proof pressure test being carried out at intervals as frequently as two years (pre-1940). With increasing experience and confidence so gained, together with improved cylinder manufacturing quality, it has been possible to exempt welded steel LPG cylinders from a statutory periodic retest as indicated in this standard.

Periodic inspection is carried out at a test station operating under the approval of the relevant national department (see foreword) together with the national accreditation authority (see foreword). **Amdt 1**

Contents

	Page
Foreword	
Introduction	
1 Scope	3
2 Normative references	3
3 Definitions	5
4 Requirements.....	6
5 Accreditation of test stations.....	9
6 Identification of cylinder and preparation for inspections and tests.....	12
Amdt 2	
7 Cylinder records and inspection reports/certificates	12
8 Basic equipment	14
9 Revalidation of pressure receptacles	15
10 Defects	17
Annex A (normative) Withdrawn cylinder specifications	18
Annex B (normative) Obstructed valve identification and removal	24
Annex C (informative) Route for inspection and testing of cylinders	26
Annex D (normative) LPG cylinder inspection and test procedures	27
Annex E (informative) System of protection against external corrosion	35
Annex F (normative) Test date rings for gas cylinders	36
Annex G (normative) Test pressure requirements for DOT pressure receptacles	37
Bibliography	39
Amdt 1	

Gas cylinder test stations — General requirements for periodic inspection and testing of transportable refillable gas pressure receptacles

1 Scope

1.1 This standard specifies minimum requirements for test stations for transportable gas cylinders of water capacity 0,5 L to 3 000 L, including gas cylinders used in fixed fire-fighting systems.

Amdt 1

1.2 Where an approved test station carries out the replacement of cylinder valves then that activity shall be included in the scope of activity for the gas test station.

1.3 This standard excludes the testing of hand-held fire extinguishers with an operating pressure less than 2 000 kPa.

1.4 This standard does not apply to facilities where only cylinder valves or screw-on type valve guards are replaced, or where the straightening of bent foot rings or valve guards are carried out without the application of heat.

2 Normative references

The following referenced documents are indispensable for the application of this document. For dated references, only the edition cited applies. For undated references, the latest edition of the referenced document (including any amendments) applies. Information on currently valid national and international standards can be obtained from the South African Bureau of Standards.

BS 8562, *Gas cylinders – In situ, non-destructive examination and testing of refillable seamless steel tubes of water capacity between 150 L and 3 000 L, used for compressed gases – Specification.*

49-CFR-107, *Approval of independent inspection agencies, cylinder re-qualifiers, and non-domestic chemical analyses and tests of dot specification cylinders.*

Amdt 2

49-CFR-178, *Specifications for packagings.*

Amdt 2

49-CFR-180, *Continuing qualification and maintenance of packagings.*

Amdt 2

EIGA Doc. 79/13/E section 7, *Cylinder retest station.*

EN 837-1, *Pressure gauges – Part 1: Bourdon tube pressure gauges – Dimensions, metrology requirements and testing.*

SANS 1825:2021

Edition 4.2

EN 837-3, *Pressure gauges – Part 3: Diaphragm and capsule pressure gauges – Dimensions, metrology, requirements and testing.*

EN 14876, *Transportable gas cylinders – Periodic inspection and testing of welded steel pressure drums.*

ISO 8504-1, *Preparation of steel substrates before application of paints and related products – Surface preparation methods – Part 1: General principles.*

ISO 8504-2, *Preparation of steel substrates before application of paints and related products – Surface preparation methods – Part 2: Abrasive blast-cleaning.*

ISO 11114-1, *Gas cylinders – Compatibility of cylinder and valve materials with gas contents – Part 1: Metallic materials*

ISO 13338, *Gases and mixtures – Determination of tissue corrosiveness for the selection of cylinder valve outlets.*

ISO 13341, *Gas cylinders – Fitting of valves to gas cylinders.*

ISO 13769, *Gas cylinders – Stamp marking.*

ISO 16148, *Gas cylinders – Refillable seamless steel gas cylinders and tubes – Acoustic emission examination (AT) and follow-up ultrasonic examination (UT) for periodic inspection and testing.*

Amdt 1

ISO 18119, *Gas cylinders – Seamless steel and seamless aluminium-alloy gas cylinders and tubes – Periodic inspection and testing.*

Amdt 1

SANS 199, *Shutt-off valves for transportable, refillable liquefied petroleum gas cylinders.*

SANS 6406/ISO 6406, *Gas cylinders – Seamless steel gas cylinders – Periodic inspection and testing.*

SANS 10019, *Transportable pressure receptacles for compressed, dissolved and liquefied gases – Basic design, manufacture, use and maintenance.*

~~SANS 10400 (all parts), *The application of the National Building Regulations.*~~

Amdt 1

SANS 10460/ISO 10460, *Gas cylinders – Welded carbon-steel gas cylinders – Periodic inspection and testing.*

SANS 10461/ISO 10461, *Gas cylinders – Seamless aluminium-alloy gas cylinders – Periodic inspection and testing.*

SANS 10462/ISO 10462, *Gas cylinders – Transportable cylinders for dissolved acetylene – Periodic inspection and maintenance.*

SANS 11120/ISO 11120, *Gas cylinders – Refillable seamless steel tubes of water capacity between 150 L and 3 000 L – Design, construction and testing.*

SANS 11623/ISO 11623, *Gas cylinders – Composite construction – Periodic inspection and testing.*

SANS 17020/ISO/IEC 17020, *Conformity assessment – Requirements for the operation of various types of bodies performing inspection.*

3 Definitions

For the purposes of this document, the following definitions apply.

3.1

accreditation body

government-endorsed national accreditation body (see foreword)

Amdt 1

3.2

approved

approved by the regulatory authority

3.3

approved inspection authority

organization that is approved by the regulatory authority

3.4

approved test station

test station holding accreditation in terms of the requirements of this standard and SANS 17020

3.5

competent person

person that has the knowledge, training and experience specific to the work being performed

3.6

pressure receptacle

collective term that includes cylinders, bundles, tubes and pressure drums for the storage and transportation of liquefied or compressed gases that have a water capacity of 0,5 L to 3 000 L

NOTE 1 All types of pressure receptacles, excluding non-refillable cylinders, are refillable.

NOTE 2 The terms "transportable gas cylinder", "transportable pressure cylinders" and "cylinders" as used in the relevant national legislation (see foreword), European Industrial Gases Association (EIGA) documents, and the various manufacturing specifications listed in annex A are deemed to have the same meaning as "pressure receptacle", as defined in SANS 10019.

Amdt 1

3.6.1

bundle

assembly of cylinders that are fastened together and interconnected by a manifold and transported as a unit, and that have a total water capacity that does not exceed 3 000 L

NOTE Bundles intended for the transport of toxic gases are limited to a water capacity of 1 000 L.

3.6.2

cylinder

transportable pressure receptacle (that may be seamless, welded or composite) of water capacity 0,5 L to 150 L

3.6.3

pressure drum

welded transportable pressure receptacle of water capacity that exceeds 150 L but does not exceed 1 000 L (e.g. cylindrical pressure receptacles equipped with rolling rings, spheres on skids and dumpy tanks incorporating skids)

3.6.4

tube

seamless transportable pressure receptacle of water capacity that exceeds 150 L but does not exceed 3 000 L

SANS 1825:2021

Edition 4.2

3.7

regulatory authority

appropriate of the following:

- a) within the scope of the relevant national legislation (see foreword): the Chief Inspector; **Amdt 1**
- b) Deleted by amendment No. 1.
- c) Deleted by amendment No. 1.

3.8

water capacity

total internal volumetric capacity of a pressure receptacle

4 Requirements

4.1 Standards

Cylinders shall be periodically inspected and tested in accordance with the appropriate requirements of the following standards:

- a) refillable seamless steel gas cylinders with a water capacity of up to 150 L: SANS 6406. This SANS standard will become obsolete on 26 Feb 2022 and is replaced by ISO18119;
- b) dissolved acetylene cylinders with a water capacity of up to 150 L: SANS 10462;
- c) welded carbon steel cylinders, excluding LPG cylinders with a water capacity of up to 450 L: SANS 10460;
- d) seamless aluminium-alloy cylinders with a water capacity of up to 150 L: SANS 10461. This SANS standard will become obsolete on 26 Feb 2022 and is replaced by ISO18119;
- e) seamless steel tubes of water capacity between 150 L and 3000 L, used for compressed gases - in situ, non-destructive examination and testing: BS 8562;
- f) composite cylinders with a water capacity of up to 450 L: SANS 11623;
- g) welded steel pressure drums of water capacity 150 L to 1 000 L: EN 14876; **Amdt 1**
- h) welded steel LPG cylinders with a water capacity of up to 150 L and LPG dumpies 150 L up to 500 L: (see annex D);
- i) Where gas test stations are approved in terms of 49-CFR-107.805 and are in possession of a requalifies RIN issued by the DOT in the USA, DOT cylinders shall be revalidated in full compliance with the granted DOT Approval. **Amdt 2**
- j) DOT specification cylinders that are tested for use in South Africa, shall be tested using the appropriate of the standards in a), b) c), d), e) or h). DOT cylinders are marked with the service pressure and not the test pressure. See annex G to establish the required test pressure per DOT cylinder type; **Amdt 1; amdt 2**
- k) seamless steel tubes of water capacity between 150 L and 3000 L, used for compressed gases: SANS 11120; **Amdt 1; amdt 2**
- l) seamless steel and seamless aluminium-alloy gas cylinders with water capacity of up to 150 L: ISO 18119; **Amdt 1; amdt 2**

m) seamless steel and seamless aluminium-alloy tubes with water capacity greater than 150 L: ISO 18119. **Amdt 1; amdt 2**

n) refillable seamless gas cylinders and tubes – Acoustic emission examination (AT) and follow-up ultrasonic examination (UT) for periodic inspection and testing: ISO 16148 **Amdt 1; amdt 2**

4.2 Frequency of inspections and tests

4.2.1 General

The internal inspection and hydrostatic test periods applicable in South Africa (see table 1) override the frequency and test stipulations as specified in the standards given in 4.1.

4.2.2 Test date rings

4.2.2.1 Coloured test date rings (see table F.1) shall be used on cylinders, to identify the month and year that the inspection and hydro-test was carried out. They allow the filler to easily identify the date of the last inspection and hydro-test.

Plastic test date rings are not an alternative to the mandatory hard stamp markings.

NOTE 1 Plastic test date rings are not used on LPG cylinders to denote the date of the last cylinder retest.

NOTE 2 Coloured test date rings are not compulsory for SCUBA or SCBA cylinder, but may be used.

Amdt 1

4.2.2.2 The plastic test date rings are fitted around the valve stem thread.

4.2.2.3 If the test date ring is missing the mandatory hard stamped test date markings shall be used in accordance with SANS 10019.

Table 1 — Intervals for periodic inspection and testing of pressure receptacles

1	2	3
Description of gas type	Example of pressure receptacles by gas type	Frequency of pressure receptacle inspection and testing ^a years
Receptacles for gases other than breathing gases used in the SCUBA and SCBA Industry		
Compressed gases	Ar, N ₂ , He	10
	H ₂ ^b CNG, Methane	10
	Air, O ₂	10
	Medical gases and breathing	10
	CO ^c	5
Acetylene Monolithic mass	Acetylene	Internal inspection every 10 years ^d First internal inspection 3 years after the initial massing of a cylinder shell ^d Thereafter Internal inspection every 2 years ^d
Non-monolithic mass		Internal inspection every 10 years ^d First internal inspection 2 years after the initial massing of a cylinder shell ^d

Table 1 (concluded)

1	2	3
Description of gas type	Example of pressure receptacles by gas type	Frequency of pressure receptacle inspection and testing ^a years
Receptacles for gases other than breathing gases used in the SCUBA and SCBA Industry		
Liquefied gases	Refrigerants, CO ₂ , NH ₃ , LPG ^e , LNG, He, Commercial propane ^e	10
Corrosive gases ^f		5
Toxic gases that are non-corrosive	SO ₂ F ₂	5
Very Toxic gases that are non-corrosive	AsH ₃ , PH ₃	5
Gas mixtures	All mixtures	Every 5 years and 10 years according to dangerous properties. Generally, mixtures that are toxic or corrosive have a 5-year interval, and other mixtures have a 10 year interval.
Composite cylinders	All gases	See SANS 11623
Receptacles for breathing gases used in the SCUBA and SCBA Industry		
Compressed gases	Self-Contained Breathing Apparatus air	2 year internal, 4 year hydrostatic test
	Gases for Self-Contained Underwater Breathing	2 year internal, 4 year hydrostatic test
	Oxygen and breathing gases This includes cylinders used in conjunction with a breathing air compressor and Gas system	10
Composite cylinders	All gases	See SANS 11623 – Where Inspection Intervals are greater than above listed, frequency shall take precedence.
<p>^a Local regulations shall specify the interval of periodic inspections and tests.</p> <p>^b Particular attention shall be paid to the tensile strength and surface conditions of cylinders. Cylinders that do not comply with the special hydrogen requirements shall be withdrawn from hydrogen service. (See EIGA IGC Doc. 79/13/E section 7 recommendation no. 5 for possible additional testing.)</p> <p>^c This product shall require special consideration regarding moisture content when filled in steel cylinders. (See ISO 11114-1.)</p> <p>^d Acetylene cylinder shells shall be hydrostatically tested every time the porous substance is removed.</p> <p>^e Welded steel cylinders for LPG and commercial Propane are exempt from the requirements but shall be internally inspected whenever they are hydrostatically tested. This exemption does not apply to LPG and commercial Propane cylinders manufactured from other types of materials, for example, welded aluminium alloy, welded stainless steel, all types of composite cylinders.</p> <p>^f Corrosiveness with reference to human tissue shall be determined in accordance with ISO 13338 and NOT cylinder material.</p>		

Amdt 2

4.3 CO₂ fire extinguishers

All CO₂ fire extinguishers manufactured before the year 2000 shall be pressure-tested at five-year intervals, until they are tested by an approved test station (as specified in SANS 10019). Thereafter the interval shall be 10 years. See the relevant letter issued by the relevant national department (see foreword). **Amdt 1**

5 Accreditation of test stations

5.1 General

5.1.1 A test station, before starting operations, shall apply for accreditation and shall comply with the requirements of this standard and SANS 17020. Once provisional acceptance by the government-endorsed national accreditation body (see foreword) has been granted to the test station through a letter of acknowledgement, the test station shall apply for approval from the regulatory authority. **Amdt 1**

5.1.2 The approval of a test station by the relevant national department (see foreword) shall be conditional upon the following:

- a) The activities of a test station shall be assessed at least once a year for four years after initial accreditation has been granted, under the control of the government-endorsed national accreditation body (see foreword). Every succeeding fourth assessment shall be a full reassessment. These assessments shall be done in accordance with the requirements of SANS 17020 and this standard. **Amdt 1**
- b) Should personnel that are vital to the accreditation leave the permanent employment of the test station, the accreditation shall be suspended until the test station can prove that the new incumbents have the required experience, training and qualification. Interim measures can, however, be arranged between the company, the relevant national department (see foreword) and the relevant national accreditation authority (see foreword). **Amdt 1**
- c) The Chief Inspector of the relevant national department (see foreword) shall only grant final approval to a test station in terms of the relevant national legislation (see foreword) once accreditation by the government-endorsed national accreditation body (see foreword) has been granted to the test station. This does not mean that an accredited test station will automatically be approved. The relevant Chief Inspector might wish to impose additional requirements on accredited test stations before approval is granted. **Amdt 1**
- d) If a test station loses its accreditation, it shall automatically lose its approval by the regulatory authority.

5.2 Qualification requirements

The relevant qualifications as given in table 2 shall apply to all test station personnel. Table 2 sets out the minimum qualifications and experience necessary to enhance the competence of personnel in order to comply with the requirements of this standard.

Table 2 — Qualification requirements for test station personnel

1	2	3	4
Position	Theoretical criteria	Practical criteria	Specific requirement
Technical			
Technical manager ^b	At least one-year engineering learnership (e.g. a completed apprenticeship or full learnership programme under a mechanical engineering discipline is deemed equivalent). Computer literate.	At least twelve months working experience within a gas test station directly relating to pressure receptacle inspection, testing and management of the gas test station. Ability to read and understand Standards and technical documentation. Ability to perform root cause analysis and implement effective corrective actions. Able to perform coaching, training and mentoring.	●● ▲ ▲▲ ▲▲▲ ▲▲▲▲
Quality manager ^b	SANS 17020 Computer literate	SANS 17020 Ability to effectively maintain a gas test station management system, perform root cause analysis and implement effective corrective actions.	●● ●●
Technical signatory ^{a & b}	In accordance with the requirements of the national government-endorsed accreditation body (see foreword) At least a general education grade 9 or equivalent training certificate (as assessed by an applicable and training authority (see foreword)).	In accordance with the requirements of the national government-endorsed accreditation body (see foreword). At least six months test station inspection and testing experience (within the last three years) and proof of having inspected and tested pressure receptacles against the specific specifications. (At least 3 months working experience at gas test station being appointed as Technical Signatory).	●● ▲ ▲▲ ▲▲▲ *** requirements of the national government-endorsed accreditation body (see foreword)
Pressure receptacle inspector ^a	At least a general education grade 9 or equivalent training certificate (as assessed by an applicable training authority) (see foreword)	At least six months test station inspection and testing experience (within the last three years) and proof of having inspected and tested pressure receptacles against the specific specifications. (At least 3 months working experience at gas test station being appointed as inspector)	●● ▲▲▲ * ** ***

Table 2 (continued)

1	2	3	4
Position	Theoretical criteria	Practical criteria	Specific requirement
System			
●	Personnel shall: a) demonstrate in depth knowledge of SANS 17020 and the facilities management system. b) demonstrate understanding of testing procedures of the gas test station, the requirements of this standard, SANS 10019, and the relevant national legislation (see foreword) thereof. c) attend courses specific to the job position (internal or external) with documented evidence to support their scope of accreditation. (Where internal training is performed, well documented training modules with detailed outcomes should be developed).		
●●	Position and name of individual clearly identified on gas test station's documented organogram.		
▲	Personnel shall: a) demonstrate working knowledge of SANS 17020 and the facilities management system; b) demonstrate in depth knowledge in the work instructions of the gas test station, this standard, SANS 10019, all standards forming part of the facilities accreditation and the relevant national legislation (see foreword) thereof; and c) attend courses specific to the job position (internal or external) with documented evidence to support their scope of accreditation. (Where internal training is performed, well documented training modules with detailed outcomes should be developed)		
▲▲	The practical and theoretical criteria may proceed concurrently.		
▲▲▲	Personnel with higher education qualification certificates may be considered for shorter periods (up to six months) within a workshop, provided they can show competence.		
▲▲▲▲	Personnel shall have evidence of a vision test on a 3 yearly cycle covering: a) Eyesight, either unassisted or assisted by spectacles or contact lenses, capable of reading a row of letters of sufficiently fine print (Jaeger No. 2 or finer) at a nominal distance of 300 mm, or equivalent. b) Colour vision shall be sufficient that the person can distinguish and differentiate contrast between the colours or shades for which types of cylinders are being inspected and to satisfactorily identify and distinguish between all inspection criteria. NOTE The following criteria is not acceptable: a) A person with recent loss of vision, eye disease or visual defect rendering, or likely to render, the person incapable working safely. b) An individual with total colour blindness.		
*	Personnel shall: a) demonstrate general knowledge of SANS 17020 and the facilities management system, the requirements of this standard, SANS 10019 and the relevant national legislation (see foreword) thereof. b) demonstrate in depth knowledge in the specific work instructions of the gas test station, and specific sections of all standards forming part of the facilities accreditation, that the inspector has been deemed competent by the gas test station. c) attend courses specific to the job position (internal or external) with documented evidence to support their competence. (Where internal training is performed, well documented training modules with detailed outcomes should be developed).		

Amdt 2

Table 2 (concluded)

1	2	3	4
Position	Theoretical criteria	Practical criteria	Specific requirement
System			
**	The practical and theoretical criteria may proceed concurrently.		
***	Personnel with higher education qualification certificates may be considered for shorter periods (Up to 3 months) within a workshop, provided they can show competence.		
^a	The six-month test station and three-month working experience may be relaxed with special permission obtained from the accreditation and approvals body.		
^b	These positions are required to be listed on the gas test stations Schedule of Accreditation.		

Amdt 2

5.3 Certificate

A certificate that contains the scope of accreditation shall be issued by the government-endorsed national accreditation body (see foreword). A further certificate shall be issued by the relevant national department (see foreword). Both certificates shall be displayed prominently at all times. This requirement includes mobile test stations.

Amdt 1

5.4 Registered trade mark or symbol

Each approved test station shall have a registered trade mark or symbol. The test station mark shall be hard-stamped onto the cylinder adjacent to the current test date. The test station mark shall be registered with the relevant government-endorsed accreditation body (see foreword).

Amdt 1

6 Identification of cylinder and preparation for inspections and tests

Amdt 2

Before any test work is done to any pressure receptacle, such receptacle shall have been pre-inspected in accordance with the requirements of the relevant standard in 4.1. This is to establish if any repairs to a pressure receptacle are needed before testing.

7 Cylinder records and inspection reports/certificates

7.1 A test station shall maintain records (written or electronic) as required by the applicable standard. Where no time frame is given in the standard, the test station shall maintain, for not less than twelve years (7 years for cylinders with a cylinder test period 5 years or less), a written or electronic system of records of all cylinders tested or inspected.

7.2 These records/reports/certificates shall contain the results of all the tests, inspections and examinations conducted at the test station. Reports/certificate shall be made available to the cylinder owner(s) or user. The records/reports/certificates maintained by the test station shall contain the following information:

Amdt 2

- a) identification symbol and name of the test station or testing body;
- b) name of owner(s) or user(s);
- c) manufacturer's or owner's serial number;
- d) cylinder mass (empty shell mass), or tare (in accordance with ISO 13769), where applicable;

- e) test pressure;
- f) date of test – year/month;
- g) complete manufacturing design specification, including service pressure, in psi, for DOT specification cylinders; **Amdt 2**
- h) water capacity, when marked on the cylinder. The water capacity shall be marked on all cylinders in liquefied gas service. Where a change of service requires the water capacity to be hard-stamped on the cylinder, it shall be determined by the approved test station, and then be hard-stamped; for welded steel cylinders on the designated area for seamless cylinders on the shoulder;
- i) unique identification number of the inspection report/certificate;
- j) type of tests done;
- k) result of test (pass or fail – including the reason for failure);
- l) identification and signature of pressure receptacle inspector and the technical signatory on raw data forms/records retained as part of inspection and identification of pressure receptacle inspector and identification and signature of the technical signatory on certificates/reports issued to owner/customer; **Amdt 2**
- m) details of any repairs to welded cylinders in accordance with the standards in 4.1 (where applicable);
- n) information that has been added to a pressure receptacle or to the data sheet; and
- o) the test station's approval number. **Amdt 2**

7.3 The test station shall issue the pressure receptacle owner with a test report for each pressure receptacle tested. **Amdt 2**

NOTE A test report for multiple pressure receptacles tested may be issued to the owner. **Amdt 2**

7.4 Where the following information is missing on a pressure receptacle, the pressure receptacle shall be scrapped:

- a) design specification;

NOTE Notwithstanding the requirement given in 7.3 (a), in cases where the design specification is not stamped on the cylinder, and the cylinder owner is able to obtain written evidence of the manufacturing design standard from the manufacturer and a copy of the original manufacturing certification for the cylinder(s) in question, then the design standard should be stamped on the cylinder(s) by the approved test station and the cylinder(s) may then be tested.

- b) test pressure (for Department of Transport (DOT) and the Canadian Interstate Commerce Commission (ICC) cylinders, the service pressure).

NOTE 1 Where the working or service pressure is available and the design specification is known, the test pressure can be calculated as specified in annex G. **Amdt 1**

NOTE 2 The calculated test pressure may be hard-stamped onto the cylinder shoulder, for example PH xxx kPa/MPa.

8 Basic equipment

A test station shall have at least the basic equipment required for inspection and testing (see table 3).

Table 3 — Basic equipment for test stations

1	2	3	4
Equipment	Welded or brazed	Seamless	Acetylene Welded/seamless massed cylinder
Re-qualification standard	See 4.1		
Work procedures	♦	♦	♦
Internal inspection equipment ^e and light ^l	♦ ^j	♦ ^j	♦ ^{a+j}
Obstructed valve equipment ^b	♦	♦	♦
Measuring devices for detection of surface rejection limits including corrosion	♦	♦	♦
Thread gauging and thread cleaning equipment ^c	♦	♦	♦
Metal stamps	♦	♦	♦
Cleaning equipment ^d	♦	♦	♦
Clamping equipment	♦	♦	♦
Scales ^f	♦	♦	♦
Ultrasonic wall thickness measuring devices ^g	□	□	□
Hydrostatic test equipment ^h	♦	♦	♦
Torque equipment ⁱ	♦	♦	♦
Eddy current testing equipment for aluminium cylinders	□	□	—
Hardness tester	□	□	—
† Requirement □ Optional			
^a The internal inspection and test can only be performed after the porous substance has been removed from the acetylene cylinder. However, an internal inspection to ensure that the porous substance has not degraded can be done with the porous substance in place. Where an inspection light is used to establish the condition of the porous substance, this light shall be flame proof Class 1, Zone 1, Ext.			
^b Obstructed valve equipment is necessary for the removal of obstructed valves. However, because of the design requirements, this is not applicable to fire extinguisher valves.			
^c Thread gauging is required to ensure the integrity of parallel threads. In the case of taper threads where the gauge exceeds the maximum gauge limit, re-machining may be considered at the discretion of a competent person (as defined in the relevant national legislation (see foreword). See 6.2 in SANS 17020. Where valves are fitted by a test station, they shall be visually inspected and verified for thread compatibility.			

Table 3 (concluded)

1	2	3	4
Equipment	Welded or brazed	Seamless	Acetylene Welded/seamless massed cylinder
<p>^d Cleaning equipment can be divided into two categories, namely mechanical cleaning equipment (e.g. shot blasting and wire brush) and chemical cleaning equipment. This equipment is for both internal and external cleaning. For composite cylinders see the manufacturer's recommendations and SANS 11623. The nature of the internal cleaning shall take into account the intended gas service.</p> <p>^e The internal inspection equipment shall include equipment to facilitate effective inspection of the shoulder, from the bottom of the thread to where the parallel section starts.</p> <p>^f Only calibrated scales shall be used when the mass of cylinders is determined.</p> <p>^g Hand held Ultrasonic thickness measuring devices for verification should only be used for determining the local wall thickness of surface defects. Operators should demonstrate knowledge of equipment and inspection principles.</p> <p>^h Should a test station not be equipped for hydrostatic testing, an approved alternative test method (see SANS 10019) and the following should be applied:</p> <ol style="list-style-type: none"> 1) Bourdon tube pressure gauges when fitted within cylinder hydrotest systems, shall comply with EN 837-1 with a 1 % accuracy (class 1) or better. 2) The pressure gauge shall be selected such that the cylinder test pressure is approximately between one third and two thirds of the full-scale range of the pressure gauge. 3) Example 1. Cylinder test pressure 400 bar the full-scale gauge reading is = $400/0.666 = 600$ bar. Use a 0 to 600 bar pressure gauge. 4) Example 2. Cylinder Test Pressure 30 bar the full-scale gauge reading is = $30/0.333 = 90$ bar. Use an available 0 to 100 bar pressure gauge. 5) For cylinders with test pressures up to 100 bar use a pressure gauge having a minimum nominal size of diameter 100 mm and 5 bar scale intervals. 6) For cylinders with test pressures greater than 100 bar use a pressure gauge having a minimum nominal size of 160 mm and 10 bar scale intervals. 7) Where pressure gauges are subject to pulsations it is recommended to use a glycerine filled gauge. 8) Digital pressure gauges of equal or greater precision are acceptable. <p>ⁱ Where no devalving or valving is undertaken by the test station, torque equipment is not required.</p> <p>^j The inspection light shall be bright enough to ensure a clear and good vision of the inside of the cylinder. The suggested luminosity requirements for the inspection light are 70 lumens for cylinders of 20 L water capacity and below. For cylinders greater than 20 L water capacity 140 lumens. When internally inspecting pressure receptacles that either contained or have contained flammable gases, the use of a fibre optic inspection light is recommended. The light intensity shall be such that the product of corrosion and or imperfections can be clearly identified.</p>			

Amdt 2

9 Revalidation of pressure receptacles

9.1 General

9.1.1 Pressure receptacles that have been identified by the test station for repair and re-work shall be repaired and re-worked in accordance with the requirements of SANS 10019. Periodic inspections and testing intervals shall be as specified in table 1.

SANS 1825:2021

Edition 4.2

Where repairs to cylinders are to be performed, see the applicable standards in 4.1. All repairs that require the application of heat to the body or any component part of the body shall be carried out under the direction and supervision of an approved inspection authority. The pressure receptacle shall be hydrostatically tested and verified by an approved test station before being placed back into service. **Amdt 2**

Under no circumstances shall seamless pressure receptacles of any size be repaired.

NOTE See annex C for a flowchart showing the route for inspection and testing of cylinders.

9.1.2 Before removing any pressure-retaining accessory, for example valves or flanges, a positive check shall be performed to ensure that the cylinder is not under any internal pressure. This shall be performed in accordance with annex B, using the device as shown in figure B.1.

The valve shall be removed, provided all the above requirements have been complied with and the cylinder has been depressurized safely.

9.1.3 No permanent marking shall be removed from any pressure receptacle, however, where a change of ownership takes place, the previous owner's marks may be cancelled by over-stamping using a letter "X". The serial number shall never be removed from any pressure receptacle.

9.1.4 Where used pressure receptacles are imported into the country, they shall be revalidated by an accredited international or local test station before being declared fit for service. SANS 10019 shall be used for current approved standards and annex A shall be used for approved specifications which have been withdrawn or replaced.

9.2 Depressurization of cylinders

All cylinders shall be depressurized and emptied in a safe and controlled manner before any test work is initiated. Particular attention shall be given to cylinders containing flammable, oxidizing, corrosive or toxic gases to eliminate risks at the internal inspection stage. (See annex B)

9.3 Incorrect pressure receptacle markings

Pressure receptacles with unknown gas content, or those that cannot be safely emptied of gas, shall be set aside for special handling, in accordance with documented procedures. Cylinders with incorrect markings or illegible markings or markings that are missing shall be rendered unserviceable (see 7.2 (a) to (h)).

9.4 Damaged pressure receptacles

Any cylinder damaged beyond the failure limits indicated in the applicable standard in 4.1 shall be scrapped and shall not be sent for repair or re-working. The owner or user, or both, of such cylinder(s) shall be informed of this action in writing.

9.5 Resale of and scrapping/rejection criteria for pressure receptacles

Amdt 1

9.5.1 The decision to reject a cylinder may be taken at any stage during the inspection and testing procedure. If it is impossible to recover a rejected cylinder, the test station shall, after the owner has been notified, make the cylinder unserviceable for holding gas under pressure so that it is impossible for any part of the cylinder, especially the shoulder, to be re-issued into service. In case of any disagreement, the test station shall ensure that the owner of the cylinder is made aware of and understand the possible future ramifications.

For cylinders owned by external parties to the gas test station, where the owner is in refusal to have the cylinders rendered unserviceable, or where there is an ongoing process in place for clarification of manufacturing standards, the gas test station shall document and record it accordingly after informing the client and prior to returning the cylinders back to the owner. In such a case, the cylinders shall be returned with documentation stating the reason for rejection and without the valve fitted, thereby making the cylinders unable to hold pressure. **Amdt 2**

In the case of acetylene cylinders it is the owners responsibility to ensure that the cylinders are disposed of in a safe manner taking into account of the contents of the cylinders which could contain asbestos. The contents of acetylene cylinders shall be disposed of via a company registered to carry out such disposal. Where such a company disposes of the cylinder shell, a scrap certificate shall be provided to the owner of the cylinders. **Amdt 1**

9.5.2 Scrapped or rejected cylinders shall not be resold to a third party other than a scrap merchant. When cylinders are to be sold as scrap, such cylinders shall be deformed by an approved test station to prevent them from being used again. The filling station or test station shall ensure that any cylinder that does not comply with the design standard is scrapped (see also 9.4).

9.5.3 Before any of the following steps are taken, care shall be taken to ensure that the cylinder is empty (see 9.2).

The following are recommended methods for rendering a cylinder unserviceable:

- a) crushing the cylinder using mechanical means;
- b) burning an irregular hole in the top dome equivalent in area to approximately 10 % of the area of the top dome, or piercing the cylinder shell in at least three places;
- c) irregular cutting of the neck;
- d) irregular cutting of the cylinder into two or more pieces, including the shoulder; and
- e) bursting the cylinder using a safe method.

10 Defects

10.1 General

Defects in gas cylinders can be physical, material or due to corrosion as a result of environmental or service conditions.

10.2 Physical and material defects

Physical and material defects in the cylinder shell shall be evaluated in accordance with the applicable revalidation standard (see 4.1). See annex D for LPG cylinders.

Any defect that presents a sharp notch can be removed by grinding, machining or other approved methods. Grinding shall not be allowed on any welded cylinder. After repair, the remaining wall thickness shall be checked. Ultrasonic test equipment can be used for this purpose.

Special attention shall be given to permanent attachments (for example foot rings or shrouds) and these shall be fit for the intended purposes, such as stacking cylinders safely.

NOTE For composite cylinders of type 3 and 4 reference should be made to EIGA Doc 221/19.

Amdt 1

10.3 Corrosion

Cylinders, excluding LPG cylinders, shall be examined for corrosion in accordance with the standards in 4.1. See annex D for LPG cylinders.

Annex A
(normative)

Withdrawn cylinder specifications

A.1 General

Cylinders have a potentially long lifespan under normal circumstances. The following tables provide design specifications to which cylinders were manufactured and are currently used in the Republic of South Africa. In order for these cylinders to remain in circulation they shall comply with the inspection and retest requirements as given in this standard. Where current status shows 'withdrawn' it does not preclude the manufacturer from importing and using second-hand cylinders manufactured in accordance with such a defined specification, subject to the conditions given in SANS 10019.

A.2 Approved design specifications and countries of origin

Tables A.1 to A.12 provide design specifications to which cylinders that are currently used in South Africa were manufactured.

Table A.1 — Approved design specifications originating from Australia

1	2	3
Specification number	Specification title	Current status
AS 2873	Carbon-manganese steel cylinders for compressed gases – Seamless – 0,1 kg to 500 kg	Withdrawn
AS 2874	High tensile carbon-manganese steel cylinders for compressed gases – Seamless – 0,1 kg to 500 kg	Withdrawn
AS 2875	Alloy steel cylinders for compressed gases – Seamless – 0,1 kg to 500 kg	Withdrawn
AS B10	High carbon steel cylinders for the storage and transport of permanent gases	Withdrawn
AS B11	High carbon steel cylinders for the storage and transport of high pressure liquefiable gases	Withdrawn
AS B12	Low carbon steel cylinders for the storage and transport of medium pressure liquefiable gases	Withdrawn
AS B111	Manganese steel cylinders for the storage and transport of high pressure liquefiable gases	Withdrawn
AS B113	High tensile carbon-manganese steel cylinders for the storage and transport of permanent gases and high pressure liquefiable gases	Withdrawn
AS B114	Alloy steel cylinders for the storage and transport of permanent gases and high pressure liquefiable gases	Withdrawn, superseded by AS 2875
AS B115	Welded or brazed steel cylinders for compressed gases	Withdrawn, superseded by AS 3577
AS B189	Welded capsule type steel cylinders for the storage and transport of compressed acetylene dissolved in acetone	Withdrawn, superseded by AS 2527
AS B239	Welded steel cylinders for compressed gases of capacity over 10 L (approx. 22 lb of water) up to and including 130 L (approx. 286 lb of water)	Withdrawn, superseded by AS 2470

Table A.2 — Approved design specifications originating from France

1	2	3
Specification number	Specification title	Current status
NFE 49-901	Gas cylinders – Seamless steel cylinders for compressed, liquefied or dissolved gases	Withdrawn.
NC 1969	French code for the manufacture of unfired pressure vessels: Design rules	Withdrawn, superseded by CODAP 2000 and later versions'

Amdt 2

Table A.3 — Approved design specifications originating from Germany (German Institute of Standards, standard specifications)

1	2	3
Specification number	Specification title	Current status
DIN 4661 parts 1 to 7	Gas cylinders – Welded steel gas cylinders.	Withdrawn
DIN 4663	Compressed gas containers seamless aluminium alloy cylinders, rated for 250 bar and 300 bar test pressure	Withdrawn
DIN 4664	Compressed gas containers; seamless steel gas cylinders	Withdrawn
Druckgas Verordnung (DGV)	Seamless steel gas cylinders	Withdrawn
AD MERK-BLAETTER	Technical Rules for Pressure Vessels (TRB, TRG), Druckbehvo and all sections	Withdrawn, superseded by AD 2000, EN 13445, EN 12952, EN 1591

Amdt 2

Table A.4 — Approved design specifications originating from Holland

1	2	3
Specification number	Specification title	Current status
Netherlands State Inspection Service for steam boilers and pressure vessels	Approval of cylinders under this control granted by Department of Manpower (HECI)	Unknown, treat as withdrawn.

SANS 1825:2021

Edition 4.2

Table A.5 — Approved design specifications originating from the International Organization for Standardization

1	2	3
Specification number	Specification title	Current status
ISO 4705	Refillable seamless steel gas cylinders	Withdrawn

Table A.6 — Approved design specifications originating from Italy (National Institute for Insurance against Accidents at Work (INAIL))

Amdt 1

1	2	3
Specification number	Specification title	Current status
ISPESL rules	Higher Institute for Accident Prevention and Safety at Work (Istituto Superiore per la Prevenzione e la Sicurezza del Lavoro) Rules	Withdrawn
Italian Regulations (Series XIX of NI)	Design and independent inspection of gas cylinders (SAIGAS).	Withdrawn

Amdt 2

Table A.7 — Approved design specifications originating from Japan

1	2	3
Specification number	Specification title	Current status
JIS B 8233	Refillable welded steel gas cylinders for liquefied petroleum gas	Withdrawn
JIS B 8235	Refillable welded steel gas cylinders for liquefied fluorocarbon	Withdrawn

Table A.8 — Approved design specifications originating from Lloyds Register

1	2	3
Specification number	Specification title	Current status
	Lloyds Rules and Regulations for the design and construction or use of boilers, pressure vessels, pressurized systems or portable gas cylinders	Withdrawn, superseded by EEC PED 97/23/EC

Table A.9 — Approved design specifications originating from the United Kingdom (British Standards Institution, standard specifications)

1	2	3
Specification number	Specification title	Current status
BOC DA2 BOC DA2A	Specification for steel cylinders intended for the storage of compressed acetylene contained in a porous substance (dissolved acetylene)	Withdrawn
BS 399	High carbon steel cylinders for the storage and transport of permanent gases	Withdrawn
BS 400	Low carbon steel cylinders for the storage and transport of permanent gases	Withdrawn
BS 401	Steel cylinders for the storage and transport of liquefied gases	Withdrawn
BS 5045-1	Transportable gas cylinders. Specification for seamless steel gas cylinders above 0,5 L water capacity	Withdrawn, superseded by BS 5045-7 and ISO 9809-3. See also DEL exemption letter dated 19 December 2019
BS 5045-2	Transportable gas cylinders. Specification for welded steel gas cylinders 0,5 L to 150 L water capacity with welded seams	Withdrawn, superseded by BS EN 13322-1
BS 5045-3	Transportable gas cylinders. Specification for seamless aluminium alloy gas cylinders above 0,5 L water capacity and up to 300 bar charged pressure at 15 °C	Withdrawn, superseded by BS 5045-8 and BS EN 1975
BS 5045-5	Transportable gas cylinders. Specification for aluminium alloy cylinders above 0,5 L up to 130 L water capacity with welded seams	Withdrawn, superseded by BS EN 12862
BS 6061	Specification for transportable acetylene cylinders	Withdrawn, superseded by BS EN 1800
BS 1045	Manganese steel cylinders for atmospheric gases	Withdrawn
BS 1287	High carbon steel gas cylinders for carbon dioxide, nitrous oxide and ethylene	Withdrawn
BS 1288	Manganese steel cylinders for carbon dioxide, nitrous oxide and ethylene	Withdrawn
BOCP-1	Carbon steel solid drawn cylinders intended for the conveyance of liquefied petroleum gas	Withdrawn
BS 1500-1	Fusion welded pressure vessels for use in the chemical, petroleum and allied industries – Part 1: Carbon and low alloy steels	Withdrawn, superseded by PD 5500
HOAC 1	Compressed acetylene transportable pressure receptacle	Withdrawn
HOAL-1	Seamless aluminium alloy cylinders for the conveyance of compressed gases	Withdrawn
HOAL-3	Seamless aluminium alloy cylinders for the conveyance of compressed and liquefied gas	Withdrawn
HOAL-4	Seamless aluminium alloy cylinders for the conveyance of compressed and liquefied gas	Withdrawn

SANS 1825:2021

Edition 4.2

Table A.9 (concluded)

1	2	3
Specification number	Specification title	Current status
HOS	Specification for seamless alloy steel cylinders for the conveyance of compressed gases.	Withdrawn
HOT	Specification for seamless alloy steel cylinders for the conveyance of compressed gases. (< 25 lb).	Withdrawn
GC 104	Fusion welded mild steel cylinders for transport of Low Pressure Liquefiable gases	Withdrawn

Amdt 2

Table A.10 — Approved design specifications originating from the United States of America (American Society of Mechanical Engineers, standard specifications)

1	2	3
Specification number	Specification title	Current status
(Code of Federal Regulations Title 49)	ICC (Inter-state Commerce Commission)	Withdrawn, Replaced by DOT (Department of Transportation)

Table A.11 — Approved design specifications originating from South Africa

1	2	3
Specification number	Specification title	Current status
SABS 50	The design and manufacture of seamless steel cylinders for high and low pressure service	Withdrawn
RSA CIF 3 AA	Seamless steel cylinders made of definitely prescribed steels	Withdrawn
SABS 219	The design and manufacture of welded steel cylinders for low pressure service	Withdrawn

Table A.12 — Luxfer Limited, standard specification

Amdt 1

1	2	3
Specification number	Specification title	Current status
Luxint	Luxfer gas cylinder specification: For the manufacture of aluminium cylinders	Withdrawn

Amdt 2

Table A.13 — Approved design specifications originating from Europe

1	2	3
Specification number	Specification title	Current status
84/525/EEC,	Council directive of 17 September 1984 on the approximation of the laws of the member states relating to seamless, steel gas cylinders.	Withdrawn and superseded by EU/35/2010
84/526/EEC	Council directive of 17 September 1984 on the approximation of the laws of the member states relating to seamless, unalloyed aluminium and aluminium alloy gas cylinders.	Withdrawn and superseded by EU/35/2010
84/527/EEC	Council directive of 17 September 1984 on the approximation of the laws of the member states relating to welded unalloyed steel gas cylinders.	Withdrawn and superseded by EU/35/2010
EN 1800,	Transportable gas cylinders – Acetylene cylinders – Basic requirements and definitions	Withdrawn
EN 1964-1,	Transportable gas cylinders – Specification for the design and construction of refillable transportable seamless steel gas cylinders of water capacities from 0,5 litre up to and including 150 litres – Part 1: Cylinders made of seamless steel with an Rm value of less than 1 100 MPa	Withdrawn
EN 1964-2,	Transportable gas cylinders – Specification for the design and construction of refillable transportable seamless steel gas cylinders of water capacities from 0,5 litre up to and including 150 litres – Part 2: Cylinders made of seamless steel with an Rm value of 1 100 MPa and above	Withdrawn
EN 1975	Transportable gas cylinders – Specification for the design and construction of refillable transportable seamless aluminium and aluminium alloy gas cylinders of capacity from 0,5 litre up to 150 litre	Withdrawn
EN 12205	Transportable gas cylinders – Non-refillable metallic gas cylinders	Withdrawn

Amdt 2

Annex B

(normative)

Obstructed valve identification and removal

B.1 Check for obstructed valve

B.1.1 Ensure that the following procedures are carried out only by trained personnel. In view of the potential hazards in cylinders, this operation can lead to injury from stored energy release, fire and toxic hazards, hence ensure that personnel take such precautions as are deemed necessary for the work to be performed safely.

B.1.2 Remove the valve after

- a) the gas, if any, has been released,
- b) the pressure within the cylinder has been reduced to atmospheric pressure,
- c) in the case of liquefied gases, there is no frost or dew on the outside of the cylinder, and
- d) an additional check is made to establish that there is free passage through the valve.

B.1.3 Carry out a systematic check to establish that the passage through the valve is unobstructed. If there is any doubt that gas is not being released when the valve of a gas cylinder is opened or that the cylinder might still contain residual gas under pressure, repeat the systematic check to establish that the free passage through the valve is unobstructed.

B.1.4 Ensure that the method adopted is a recognized procedure, such as one of the following or one that provides equivalent safeguards:

- a) introduce an inert gas at a pressure of up to 500 kPa and check its discharge;
- b) use the device shown in figure B.1 to hand-pump air into the cylinder;
- c) for cylinders of liquefied gases, first check to establish that the total weight of the cylinder is the same as the tare stamped on the cylinder. If there is a positive difference, the cylinder might contain either liquefied gas under pressure or contaminants. Lack of a positive difference does not rule out the presence of a gas under pressure.

B.2 Unobstructed valve

Remove the valve only when it is established that there is no obstruction to gas flow in the cylinder valve.

B.3 Obstructed valve

When a cylinder is found to have an obstructed gas passage in the valve, set the cylinder aside for special attention, and ensure that it is handled by personnel specially trained in this task, as follows:

- a) saw or drill the valve body until interception is made with the gas passage between the valve body stem and valve spindle seat. Properly cool the operation particularly when handling oxidizing gases;
- b) loosen or pierce the pressure relief safety device in a controlled manner.

Methods (a) and (b) are applicable for cylinders of non-toxic, non-flammable and non-CFC gases. Take appropriate safety precautions to ensure that no hazard results from the uncontrolled discharge of any residual gas.

Where the contents are toxic, or flammable, oxidizing or CFC (chlorofluorocarbon), the procedure is to partially unscrew the valve within a glanded cap that is secured and joined to the cylinder and vented to a safe discharge. Perform this procedure in a controlled manner and in such a way as to avoid personal injury. The principles of a typical device are shown in figure B.2.

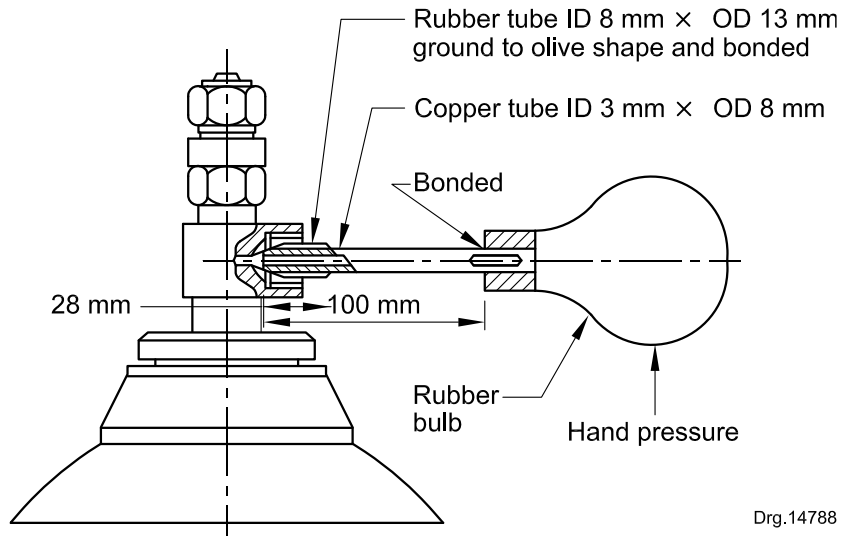
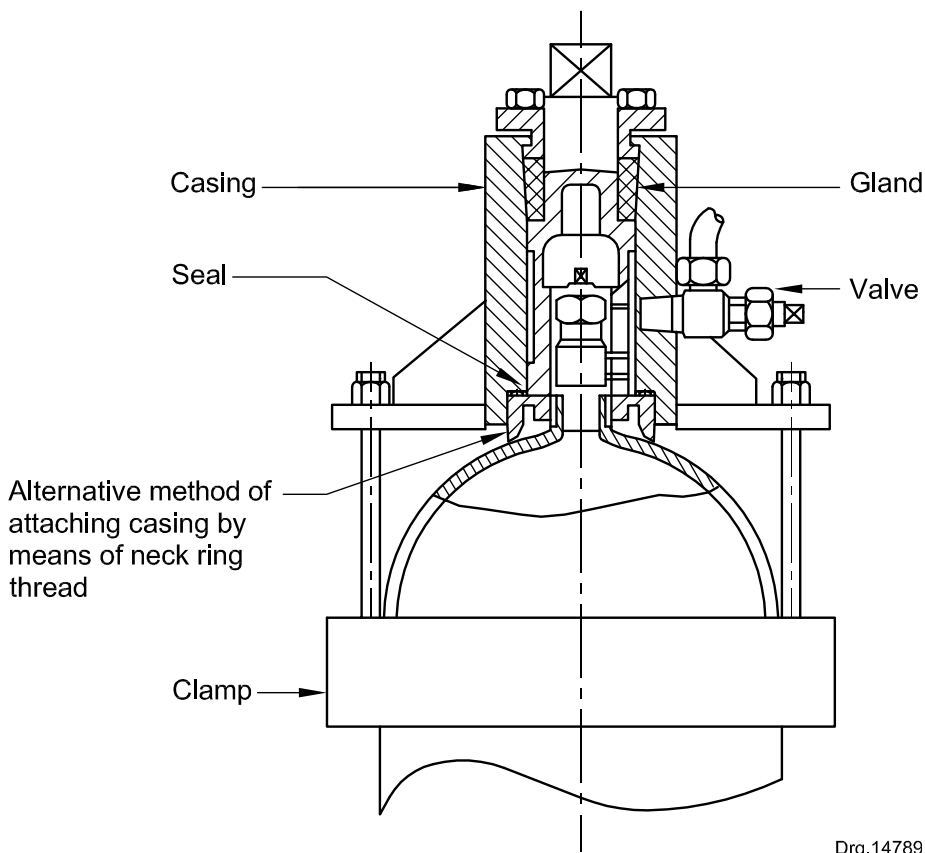

Figure B.1 — Typical device for detecting obstructed cylinder valves



NOTE Operate remotely using de-valving machine.

Figure B.2 — Typical device for the removal of damaged cylinder valves

Annex C
(informative)

Route for inspection and testing of cylinders

When a cylinder has to be reworked, it shall be done under the supervision of an approved inspection authority. This condition only applies when hot work is necessary (see SANS 10019). A flowchart showing the route for inspection and testing of cylinders is shown in figure C.1.

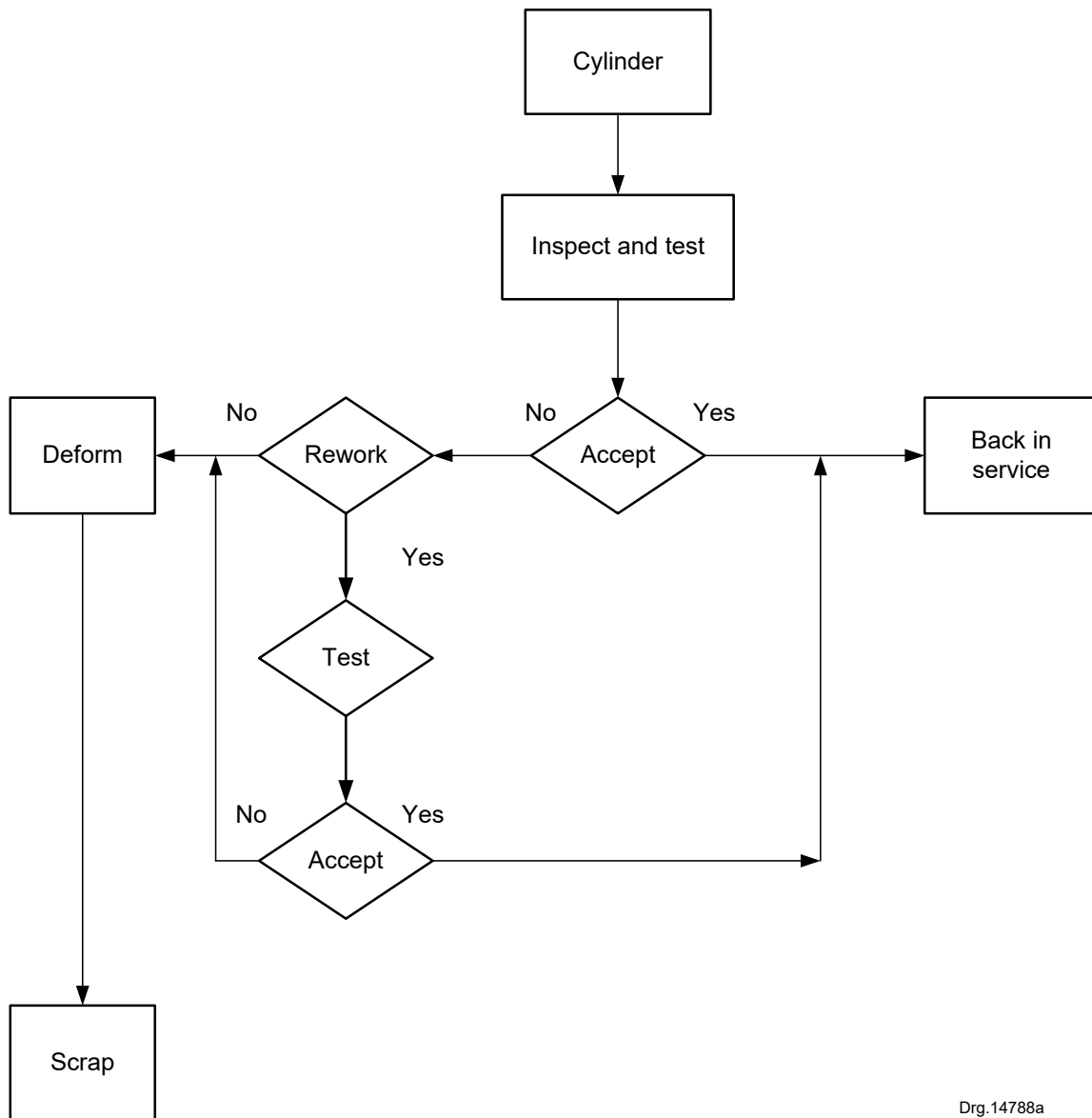

Drg.14788a

Figure C.1 — Flow chart showing route for inspection and testing of cylinders

Annex D
(normative)

LPG cylinder inspection and test procedures

D.1 Test procedures

D.1.1 General

In all cases, inspection and test procedures shall consist of the following activities carried out in the following sequence:

- a) identification of the cylinder (see D.1.2);
- b) external inspection (see D.1.3);
- c) preparation of cylinders prior to removal of valve (see D.1.3.3); **Amdt 2**
- d) internal inspection (see D.1.4); **Amdt 2**
- e) inspection of cylinder threads (see D.1.4.1); **Amdt 2**
- f) hydrostatic test (see D.1.5); **Amdt 2**
- g) drying of tested cylinders (see D.1.5.5); **Amdt 2**
- h) internal inspection after hydrostatic testing (see D.1.5.6); **Amdt 2**
- i) corrosion protection (see D.1.6 and annex E); **Amdt 2**
- j) cylinder colours (see D.1.7) **Amdt 2**
- k) re-valving of cylinders (see D.1.8); **Amdt 2**
- l) cylinder tare check (see D.1.9) **Amdt 2**
- m) re-stamping of cylinders (see D.1.10); **Amdt 2**
- n) records (see D.1.11 and clause 7); **Amdt 2**
- o) rejection and rendering cylinders unserviceable (see D.1.12); and **Amdt 2**
- p) labelling (see D.1.13). **Amdt 2**

D.1.2 Identification of cylinder

The cylinder shall be identified by the following hard stampings:

- 1) cylinder design code;
- 2) tare mass;
- 3) water capacity;
- 4) serial number; and
- 5) test pressure.

SANS 1825:2021

Edition 4.2

In the event that the cylinder design code and test pressure stamp markings are not visible, the cylinder shall not be tested and shall be scrapped in accordance with 9.5.

D.1.3 External inspection

D1.3.1 Preparation for external visual inspection

Where the cylinder surface has loose coatings, corrosion products, tar, oil or other foreign matter, these shall be removed by steel wire brushing, shot blasting in accordance with ISO 8504-2, water jet abrasive cleaning, chemical cleaning or other suitable methods.

Care shall be taken to avoid damaging the cylinder.

Cylinders treated by a process that may remove cylinder material shall be checked by a suitable means, e.g. a thickness check.

D.1.3.2 Procedure for external visual inspection

The entire surface of the cylinder shall be inspected by a competent person for the following:

- a) dents, cuts, gouges, bulges, cracks, laminations or punctures, applying the guidelines for rejection in table D.1;
- b) corrosion, giving special attention to areas where water can be trapped, at the base of the cylinder, the junction between the body and the foot ring, the junction between the body and the valve guard or shroud, and in particular hidden corrosion (for example. behind the data plate), applying the criteria for rejection given in table D.2;
- c) other defects (for example. depressed bung or fire damage), applying the criteria for rejection given in table D.1; and
- d) the integrity of all permanent attachments.

Any cylinder rejected by the competent person shall be segregated for reconditioning, for further testing or to be rendered unserviceable prior to scrapping.

D.1.3.3 Preparation of cylinders prior to removal of valve (Depressurization) Amdt 2

The cylinders shall be emptied of any liquid and depressurized in a safe and controlled manner before proceeding.

Cylinders with inoperative or blocked valves shall be brought to a place for safe valve removal (see annex B). Valves shall be removed from cylinders for inspection and maintenance.

D.1.4 Internal inspection Amdt 2

After removing any residual liquid and depressurizing the cylinder, it shall be inspected internally for any sign of corrosion or other defects that may affect its integrity. A safe inspection lighting system (e.g. explosion-proof) with appropriate internal illumination shall be used. See table 3. Amdt 2

A cylinder requiring internal mechanical cleaning shall be degassed and the loose scale or other foreign matter removed. Cylinders showing signs of internal corrosion, except those having only a film layer of surface rust, shall be removed for further detailed evaluation in accordance with table D.2.

If mechanical cleaning is required, care shall be taken to avoid damaging the cylinder walls. Cylinders shall be re-inspected after cleaning.

D.1.4.1 Inspection of cylinder threads

Amdt 2 |

D.1.4.1.1 General

If the valve (or any other fitting) is removed during periodic inspection, the cylinder threads shall be inspected in accordance with D.1.4.1.2.

Amdt 2 |

D.1.4.1.2 Internal threads

The internal threads of the cylinder shall be cleaned in a manner that will not damage the thread form and then be visually examined in order to ensure that the threads are of adequate form and are clean.

The threads shall be checked for burrs, cracks and other thread damage. The threads shall be checked using a suitable threaded or plain taper plug gauge of the appropriate thread size as given in SANS 199. Gauges shall be removed from service if physically damaged.

D.1.4.1.3 Damaged threads

Amdt 2 |

Where necessary and where the design permits, damaged threads may be repaired by a competent person.

D.1.5 Hydrostatic test

Amdt 2 |

D.1.5.1 General

Amdt 2 |

Water shall be used as the test medium.

D.1.5.2 Preparation of cylinders

Amdt 2 |

The outside surface shall be completely dried before commencing the test procedure.

D.1.5.3 Test equipment

Amdt 2 |

All rigid pipework, flexible tubing, valves, fittings and other components forming the pressure system of the test equipment shall be designed to withstand a pressure of 1,5 times the maximum test pressure of the cylinders to be tested. Flexible tubing shall have characteristics that prevent kinking.

Pressure gauges used to read the cylinder test pressure shall be in accordance with EN 837-1 and EN 837-3 (class 1 or better). They shall be calibrated or checked for accuracy against a master gauge at regular intervals. See table 3.

The master gauge shall be recalibrated in accordance with national requirements. The design and installation of the equipment and the cylinders connected to it shall ensure that no air is trapped in the system.

All joints within the system shall be leak tight.

A device shall be fitted to the test equipment to ensure that no cylinder is subjected to pressure in excess of its test pressure by more than the tolerance given in D.1.5.4 (d).

Amdt 2 |

D.1.5.4 Procedure

Amdt 2 |

- a) The minimum and standard test pressure for LPG cylinders is 3 000 kPa (see SANS 10019. Where a cylinder is submitted for test with the stamped test pressure greater than 3 000 kPa it shall be tested to the test pressure stamped on the cylinder. Where a cylinder is submitted for test with a stamped test pressure less than 3 000 kPa the cylinder may not be tested and shall not be returned to service as an LPG cylinder.

Amdt 1

SANS 1825:2021

Edition 4.2

- b) Before applying pressure, the external surface of the cylinder shall be in such condition that any leak can be detected. The cylinder shall be so positioned that the welds are visible during the test.
- c) The pressure shall be increased gradually in the cylinder until the test pressure is reached. Then the cylinder shall be isolated from the pumping system.
- d) The test pressure shall not be exceeded by more than 10 % or 200 kPa, whichever is the lesser.
- e) The test pressure shall be held for at least 30 s to carry out the test.
- f) If there is a leakage in the pressure system, it shall be corrected and the cylinders retested.
- g) Cylinders that do not leak or show any visible permanent distortion shall be deemed to have satisfied the requirements of the hydraulic test.
- h) Any cylinders that fail shall be rejected. Rejected cylinders having a pinhole leak at the weld may be repaired. Cylinders that leak through pinholes at the weld shall be rendered unserviceable or be examined by a competent person in order to determine whether they can be repaired by welding. Any welding or repairs shall be carried out in accordance with a written procedure that is approved by an approved inspection authority. Any cylinder having been repaired by the application of heat to the body (by means of a pressure envelope) of the cylinder shall thereafter be normalized and hydrotested, and all such repair work shall be carried out under the direction and supervision of an approved inspection authority (see SANS 10019).

All repaired cylinders shall be subjected to the procedures from D.1.5.4 (a) to D.1.5.4 (h). All repaired cylinders which fail a second time shall be rendered unserviceable. **Amdt 2**

D.1.5.5 Drying of tested cylinders

Amdt 2

The interior of each cylinder shall be thoroughly dried by a suitable method, at a temperature not exceeding 300 °C, immediately after hydraulic pressure testing, so that there is no trace of free water. The interior of the cylinder shall be inspected to ensure that it is dry and free from other contaminants.

NOTE LPG is not a corrosive product and when filled into a LPG cylinder it displaces traces of O₂ that would be required in order to combine with moisture in the cyl to start a process of corrosion. While it is critical that any free standing water is removed it is not a critical requirement to remove all traces of moisture from the internal walls of a cylinder **Amdt 1**

D.1.5.6 Internal inspection after hydrostatic testing

Amdt 2

After the hydrostatic test a further internal inspection shall be carried out in accordance with D.1.4. **Amdt 1; amdt 2**

D.1.6 Corrosion protection

Amdt 2

See annex E for details related to corrosion protection. **Amdt 1**

D.1.7 Cylinder colours

Amdt 2

Cylinder colours shall comply with SANS 10019 and the register held by the relevant association (see foreword). **Amdt 1**

D.1.8 Re-valving of cylinders

Amdt 2

Where the test station is responsible for re-valving a tested cylinder, the valve shall comply with SANS 199 and be tightened to the required torque given in SANS 199. The cylinder valve shall be in the closed condition after completing the re-valving operation (see ISO 13341).

D.1.9 Cylinder tare check

Where the test station is responsible for re-valving a tested cylinder, the tare weight shall be checked.

The tare shall include the mass of the cylinder, its valve(s) and all permanently attached fittings, particular attention shall be paid to the tare when replacing any valves, dip tubes, guards/shrouds and footrings. The measured tare shall be marked on the cylinder in a permanent or durable and legible fashion in accordance with ISO 13769.

Cylinder tare shall be measured using a calibrated scale with its calibration traceable to national or international standards. The scale's performance shall be checked on a daily basis. The capacity of the scale shall be suitable for the weight of the cylinder being weighed.

If the measured tare of the cylinder differs from the tare stamped on it by more than the value shown in table D.1 and the difference is not due to damage, the previous tare shall be crossed out by stamping a diagonal line through it. The new tare shall be stamped as close as possible to the previous tare. Amdt 2

Table D.1 — Maximum difference between scale weight reading to marked tare

1	2
Cylinder water capacity, V L	Maximum permissible deviation in tare g
$0,5 \leq V < 5,0$	± 50
$5,0 \leq V \leq 20$	± 200
$V > 20$	± 400

Amdt 2

D.1.10 Re-stamping of cylinders

Amdt 2

The cylinders shall be re-stamped in accordance with SANS 10019.

D.1.11 Records

Amdt 2

Cylinder records shall be maintained as given in clause 7 and SANS 10019.

Amdt 1

D.1.12 Rejection and rendering cylinders unserviceable

Amdt 2

Cylinders shall be rendered unserviceable as specified in 9.5.

Amdt 2

D.1.13 Labelling

Amdt 2

Where the test station is responsible for the application of labels to revalidated cylinders, the labels shall comply with SANS 10019. Amdt 2

Table D.2 — Rejection limits relating to physical and material defects in the LPG cylinder shell

1	2	3
Defect	Description	Rejection limit
Bulge	Visible swelling of the cylinder	Rejection in all cases
Dent	A depression in the cylinder that has neither penetrated nor removed the metal, the width of which, at any point, is greater than 2 % of the external cylinder diameter	When the depth of the dent exceeds 25 % of its width at any point ^a
Cut or gouge (see figure D.1(a))	A sharp impression where the metal has been removed or redistributed	Where the original calculated wall thickness is known: where the depth of the cut or gouge is such that the undamaged (remaining) wall is less than the minimum calculated wall thickness Where the original calculated wall thickness is not known: rejection in all cases
Intersecting cut or gouge	The point of intersection of two or more cuts or gouges	Rejection in all cases
Dent containing cut or gouge	A depression in the cylinder within which there is a cut or gouge	When the size of the dent or cut or gouge exceeds the dimensions for rejection as an individual defect
Crack (see figure D.1(b))	A split or rift in the cylinder shell	Rejection in all cases
Lamination	Layering of the material within the cylinder wall appearing as a discontinuity, crack, lap or bulge at the surface	Rejection in all cases
Depressed bung	Damage to the bung which has altered the profile of the cylinder	Rejection in all cases, or a limited level of depression or alignment deviation may be accepted as agreed with the competent person
Arc or torch burns	Burning of the cylinder base metal, a hardened heat-affected zone, the addition of extraneous weld metal, or the removal of metal by scarfing or cratering	Rejection in all cases
Fire damage ^b	Excessive general or localized heating of a cylinder, usually indicated by: <ul style="list-style-type: none"> – charring or burning of paint – fire damage of the metal – distortion of the cylinder – melting of metallic valve parts – melting of any plastic components, e.g. date ring, plug or cap 	Rejection in all cases
^a Consideration of appearance and location also plays a part in the evaluation of dents. ^b If the paint is only superficially charred, a cylinder may be accepted by a competent person.		

D.2 Corrosion

Table D.3 provides a description of the type of corrosion and the applicable rejection limits.

Table D.3 — Rejection limits for corrosion of an LPG cylinder wall

1	2	3
Defect	Description	Rejection limit
Isolated corrosion pits (see figure D.1(e))	Pitting of metal occurring in isolated areas at a concentration not greater than 1 pit per 500 mm ² of surface area	When the depth of discrete pits exceeds 0,6 mm (a greater depth can be accepted provided the depth of corrosion does not reduce the wall thickness below the minimum calculated wall thickness)
Area corrosion	Reduction in wall thickness over an area not exceeding 20 % of the cylinder surface, including the ends (top and bottom)	When the depth of penetration of any pit exceeds 0,4 mm (a greater depth can be accepted provided the depth of corrosion does not reduce the wall thickness below the minimum calculated wall thickness)
General corrosion (see figure D.1(c))	A reduction in wall thickness over an area exceeding 20 % of the cylinder surface	When the depth of penetration of any pit exceeds 0,2 mm (a greater depth can be accepted provided the depth of corrosion does not reduce the wall thickness below the minimum calculated wall thickness)
Chain pitting or line or channel corrosion (see figure D.1(d))	A series of pits or corroded cavities of limited width along the length or around the corrosion circumference	<ol style="list-style-type: none"> 1) When the total length of corrosion in any direction exceeds 50 % of the circumference of the cylinder 2) When the depth of penetration exceeds 0,4 mm (a greater depth can be accepted provided the depth of corrosion does not reduce the wall thickness below the minimum calculated wall thickness) 3) When the depth of corrosion cannot be measured
Crevice corrosion	Crevice corrosion occurs in the area of the intersection of the foot ring or shroud with the cylinder	When the depth of penetration exceeds 0,4 mm or when the depth of corrosion cannot be measured

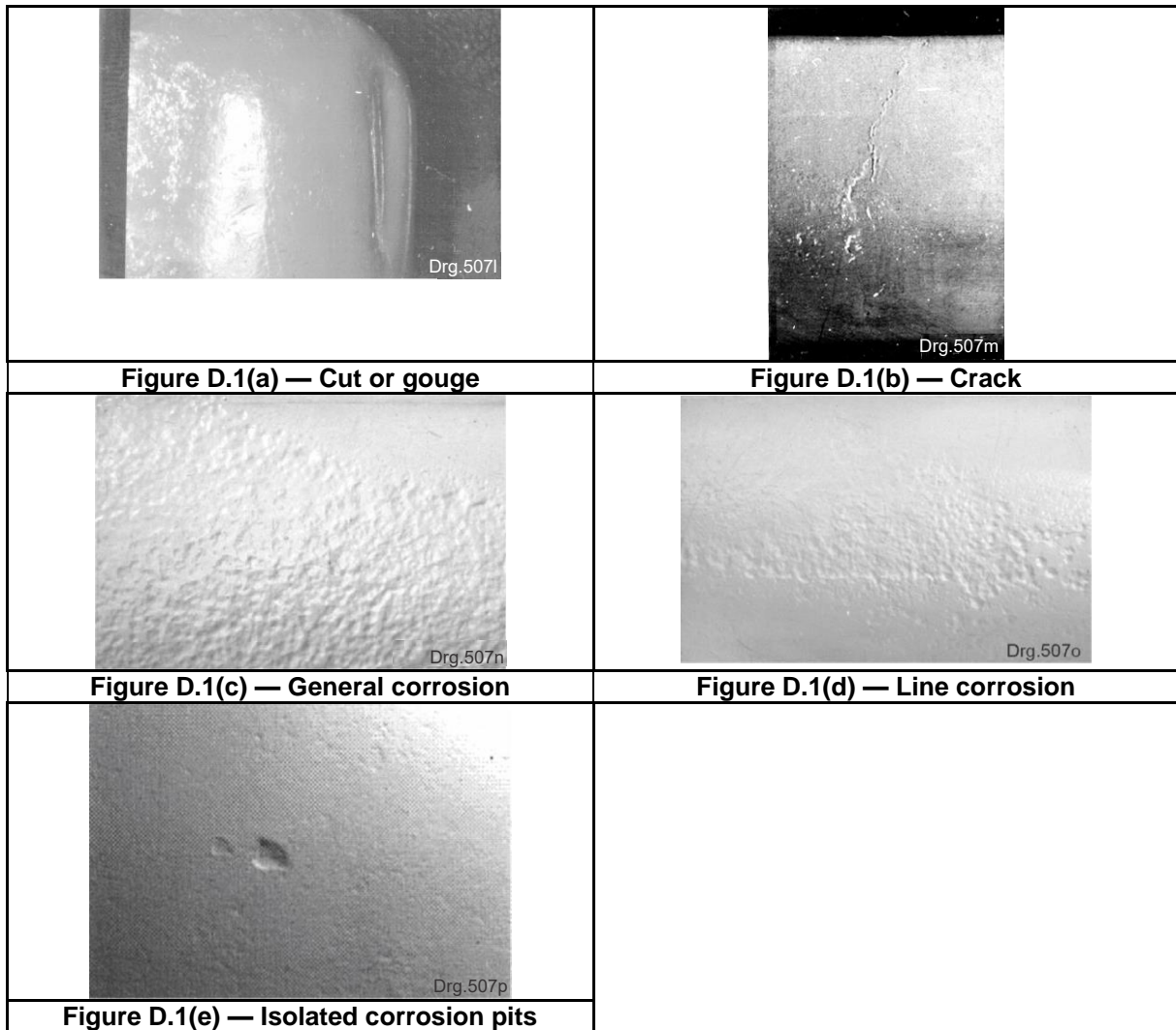

Figure D.1 — Types of defects

Internal corrosion of the metal might occur owing to the service conditions of the cylinder.

It is difficult to present definite rejection limits in tabular form for all sizes and types of LPG cylinders and their service conditions. Extensive experience and judgement are required when deciding whether cylinders that have internal corrosion or external corrosion (or both) are safe and suitable for return to service. Sound engineering judgement shall ensure that all the relevant factors affecting the safety of the cylinders are taken into account. Where applicable standards exist, these shall be used.

The surface of the metal shall be completely cleaned of corrosion products before the cylinder is inspected.

The types of corrosion are generally classified in table D.2.

Annex E (informative)

System of protection against external corrosion

E.1 Protection against corrosion

When LPG cylinders are found to show signs of serious corrosion but there is proof that they are fit-for-service, they may be further protected against corrosion as indicated in E.2 to E.5.

E.2 Pre-treatment of the cylinders

The cylinders should first be abrasive blast cleaned in accordance with ISO 8504-2. The abrasive blast cleaning quality should not be less than grade B Sa 2½ as defined in ISO 8504-1.

This quality grade should be applied to the entire surface of the cylinder. Special care should be taken with the base and the foot ring areas to ensure that no traces of rust remain in hidden crevices in the cylinder since these parts are more susceptible to corrosion.

After the abrasive blast cleaning procedure, it is essential for the success of the protection against corrosion to keep the cylinders in a dry environment until the first corrosion protection layer is applied.

E.3 First corrosion protection coating

Directly after the abrasive blast cleaning process, the cylinders should be coated with the first corrosion protection layer. It is important to make sure that this coating is thoroughly applied to all hidden crevices and to the base and foot ring areas. Such coatings could include zinc-phosphate-based primers, metallic-zinc sprays, galvanization, epoxy-based coatings, etc.

The resulting coating should be examined by visual inspection, especially when it was applied by automatic equipment. If there is any doubt as to whether the first coating has been applied satisfactorily, an additional coating should be applied.

E.4 Final coating

After application of the first coating, a final paint coating can be applied, when required. Before this step, it should be ensured that the first coating is ready for the next to be applied over it.

NOTE Some protective systems are designed to be applied wet on wet and then stoved.

Various types of paint are available for this final coating including the following:

- a) solvent-free paint (usually water-based);
- b) synthetic enamel with a low solvent content;
- c) synthetic enamel with a normal solvent content; and
- d) powder coating.

If the final coating requires stoving, care shall be taken to ensure that the mechanical properties of the cylinder material are not affected.

E.5 Cylinders which are not seriously corroded

For cylinders that are not seriously corroded, it may be sufficient to clean them, e.g. by wire brushing, before applying a corrosion protection system as necessary (see E.3 and E.4).

Annex F
(normative)

Test date rings for gas cylinders

The colours and the shapes of the rings which shall be used in order to identify cylinder test dates are indicated in table F.1.

Table F.1 — System using colour and shape of rings to identify cylinder test dates

1	2	3
Year	Colour	Shape
2000	Aluminium	Circle
2001	Red	Hexagon
2002	Blue	Hexagon
2003	Yellow	Hexagon
2004	Green	Hexagon
2005	Black	Hexagon
2006	Aluminium	Hexagon
2007	Red	Square
2008	Blue	Square
2009	Yellow	Square
2010	Green	Square
2011	Black	Square
2012	Aluminium	Square
2013	Red	Circle
2014	Blue	Circle
2015	Yellow	Circle
2016	Green	Circle
2017	Black	Circle
2018 ^a	Aluminium	Circle
2019	Red	Hexagon
2020	Blue	Hexagon
2021	Yellow	Hexagon
2022	Green	Hexagon
2023	Black	Hexagon
2024	Aluminium	Hexagon

^a The sequence of colour and shape of test date rings is to be repeated on an 18 year cycle, therefore 2018 is a repeat of 2000.

The colours of the above test date rings in accordance with the NCS system of colour coding are as follows:

Aluminium	metallic aluminium
Red	S1580-Y90R
Blue	S3060-R80B
Yellow	S0580-Y
Green	S2565-G
Black	S9000-N

Annex G
(normative)

Test pressure requirements for DOT pressure receptacles

G.1 Retest table for DOT pressure receptacles

Table G.1 shall be used to derive the retest pressure for DOT specification pressure receptacles.

Table G.1 — Test pressure requirements for DOT cylinders (extracted from United States Department of Transportation Regulations – Code of Federal Regulations 49-CFR-180.209)

Amdt 2

1	2
DOT specification	Minimum retest pressure (p.s.i.) ^a
DOT 3	3000 psig
DOT 3A, 3AA	5/3 times service pressure, except non- corrosive service (see 49-CFR-180.209(g))
DOT 3AL	5/3 times service pressure
DOT 3AX, 3AAX	5/3 times service pressure
3B, 3BN	2 times service pressure (see 49-CFR-180.209 (g))
3HT	5/3 times service pressure
3T	5/3 times service pressure
4AA480	2 times service pressure (see 49-CFR-180.209 (g))
4B, 4BA, 4BW, 4B-240ET	2 times service pressure, except non- corrosive service (see 49-CFR-180.209(g))
4D, 4DA, 4DS	2 times service pressure
DOT 4E	2 times service pressure, except non- corrosive service (see 49-CFR-180.209(g))
DOT 8, 8AL	2.4 times service pressure
Exemption or special permit cylinder ^b	See current exemption or special permit
^a For cylinders not marked with a service pressure, see 49-CFR-173.301a(b)	
^b Cylinder classified under the category of special permit cylinders shall be inspected in accordance with the stipulations and requirement of the applicable special permit or exemption if more stringent than the National requirement.	

Amdt 2

G.2 Conversion of service pressure to test pressure

As the original USA documents use imperial measurements, the following worked example provides the required information to convert the service pressure in pounds per square inch (psi) to the test pressure in bar and kPa.

The conversion factors are:

1 psi = 0,069 bar

1 psi = 6,9 kPa

SANS 1825:2021

Edition 4.2

| 14.5 psi = 1 bar
14.5 psi = 100 kPa

Amdt 2

Deleted by amendment No. 1.

The service pressure is stamped on the cylinder immediately after the cylinder type e.g. 3A – 2015. The service pressure is therefore 2015 psi.

Based on the conversion factors above 2015 psi = 139,035 bar or 13 903, 5 kPa
Rounded off, the conversions are 139 bar or 13 900 kPa

Amdt 1

Using the table G.1 the test pressure for a DOT 3 A cylinder is 5/3 of the service pressure

Therefore the test pressure for the cylinder is:

$$(139 \div 3) \times 5 = 231,667 \text{ rounded off to } 232 \text{ bar}$$

or

$$(13900 \div 3) \times 5 = 23 167 \text{ kPa rounded off to } 23 200 \text{ kPa.}$$

Amdt 1

Bibliography

AS 2337.1, *Gas cylinder test stations – Part 1: General requirements, inspection and tests – Gas cylinders.* **Amdt 2**

EIGA Doc 221/19, *Method for characterizing acceptance criteria due to mechanical impacts on composite cylinders.* **Amdt 1**
